

Arduino For Total Newbies

w/ TV-B-Gone as example project

Mitch Altman

Chief Scientist, **Cornfield Electronics**, San Francisco, CA

Inventor of **TV-B-Gone** universal remote controls

Co-founder of **3Ware** (successful Silicon Valley startup)

Pioneer of **VR** (in the mid-1980s)

Founding mentor at **HAX** (1st and biggest hardware accelerator)

Co-founder of **Noisebridge** (San Francisco hackerspace)

email: mitch@CornfieldElectronics.com

site: www.CornfieldElectronics.com

twitter: [@maltman23](https://twitter.com/maltman23)

flickr: [maltman23](https://www.flickr.com/photos/maltman23/)

WeChat: [mitchoaltman](https://www.wechat.com/qrcode/index?qr_code=mitchoaltman)



Syllabus

- Intro
- Everything You Need to Know About Electronics
- How to solder / make your own Arduino
- How to Set Up and Use the Arduino Software
- How to Hack Arduino Programs (“Sketches”)
- How to Use Solderless Breadboards
- How to Read a Schematic
- Make a TV-B-Gone Remote Control with your Arduino Clone without soldering

Bring all of this
home with you!

Stuff!

**DO NOT
open this bag
yet!**



U-Do-It-Duino kit



Parts Pack



USB-Serial
cable

(Don't bring these home)

Tools



I have these
Toolkits
for sale

Tools



Intro

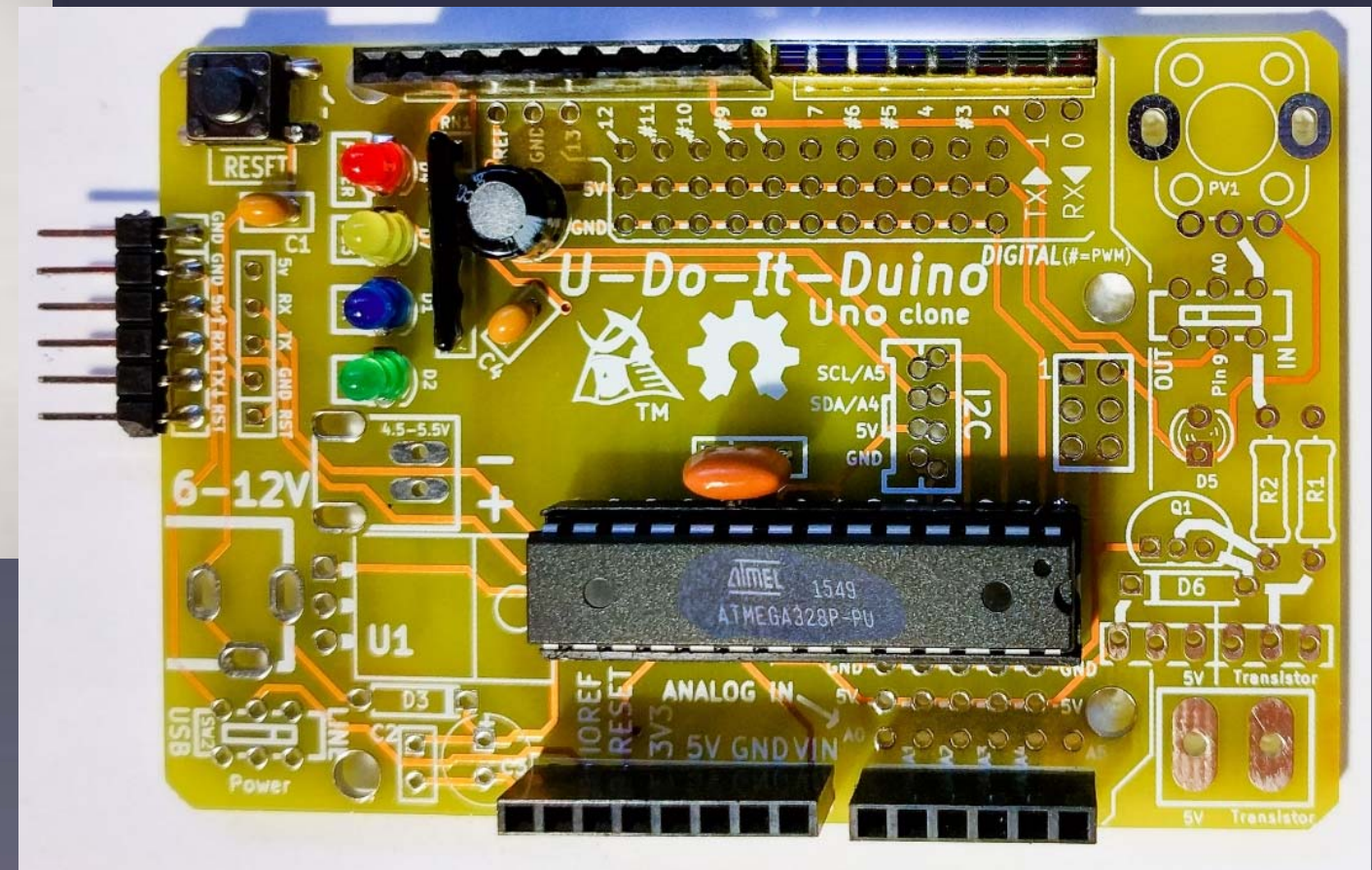
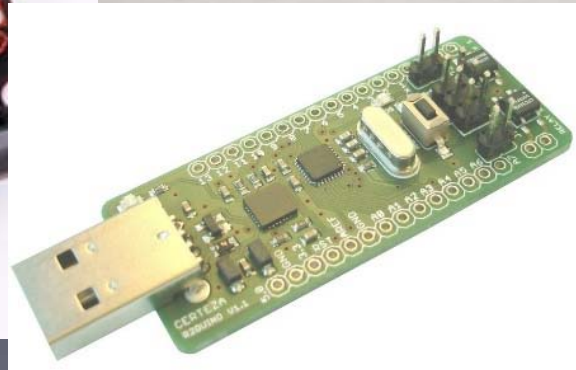
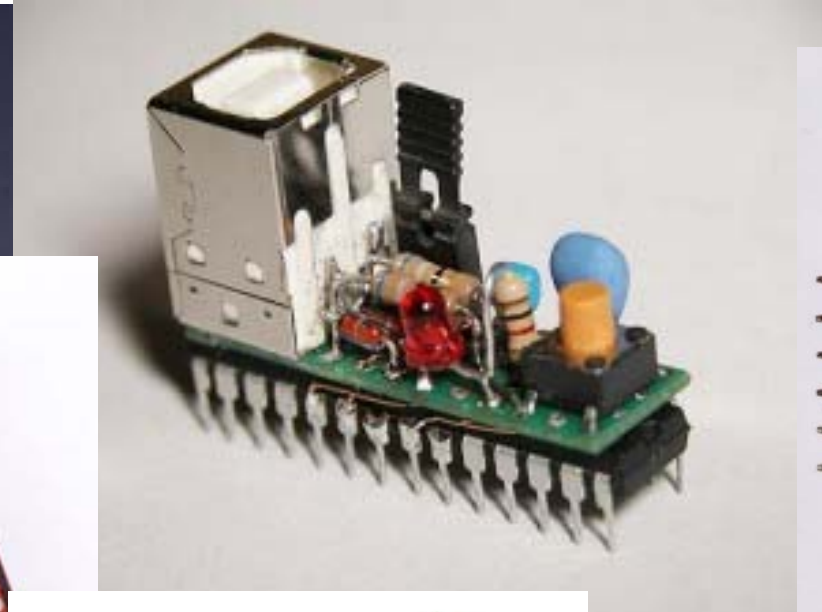
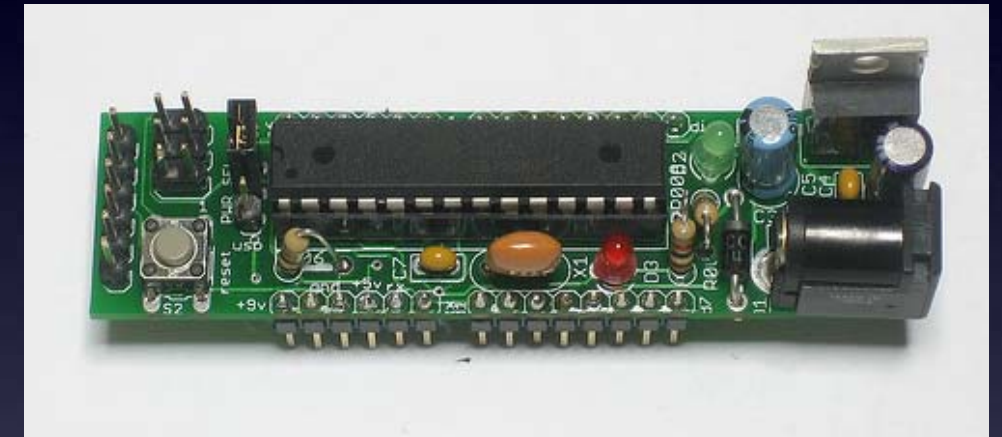
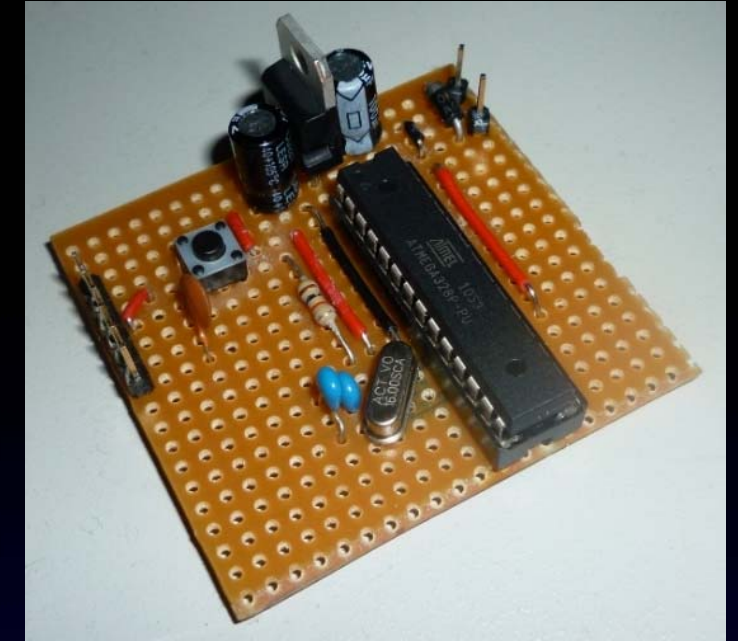
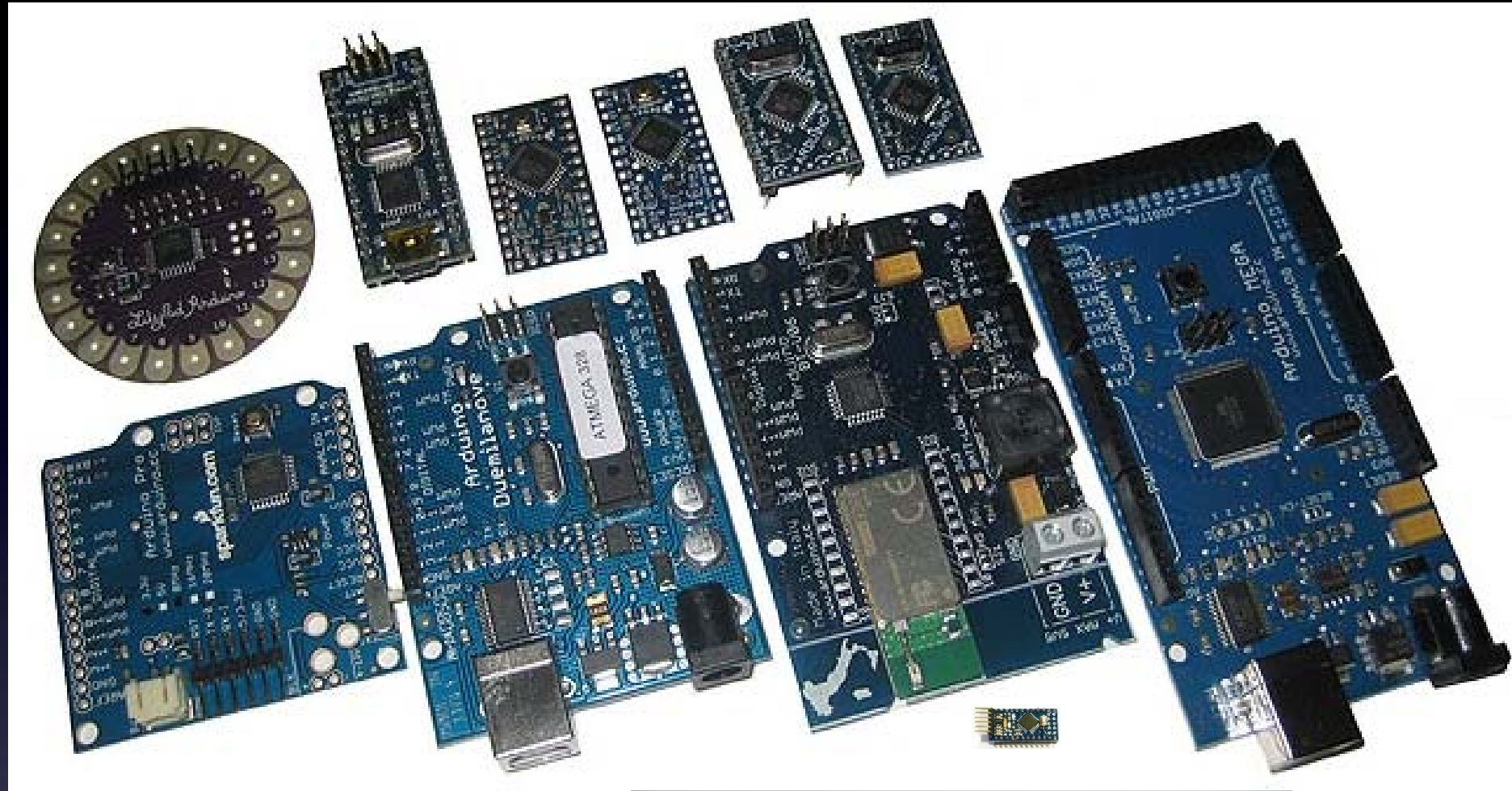

Everything You Need to Know About Electronics

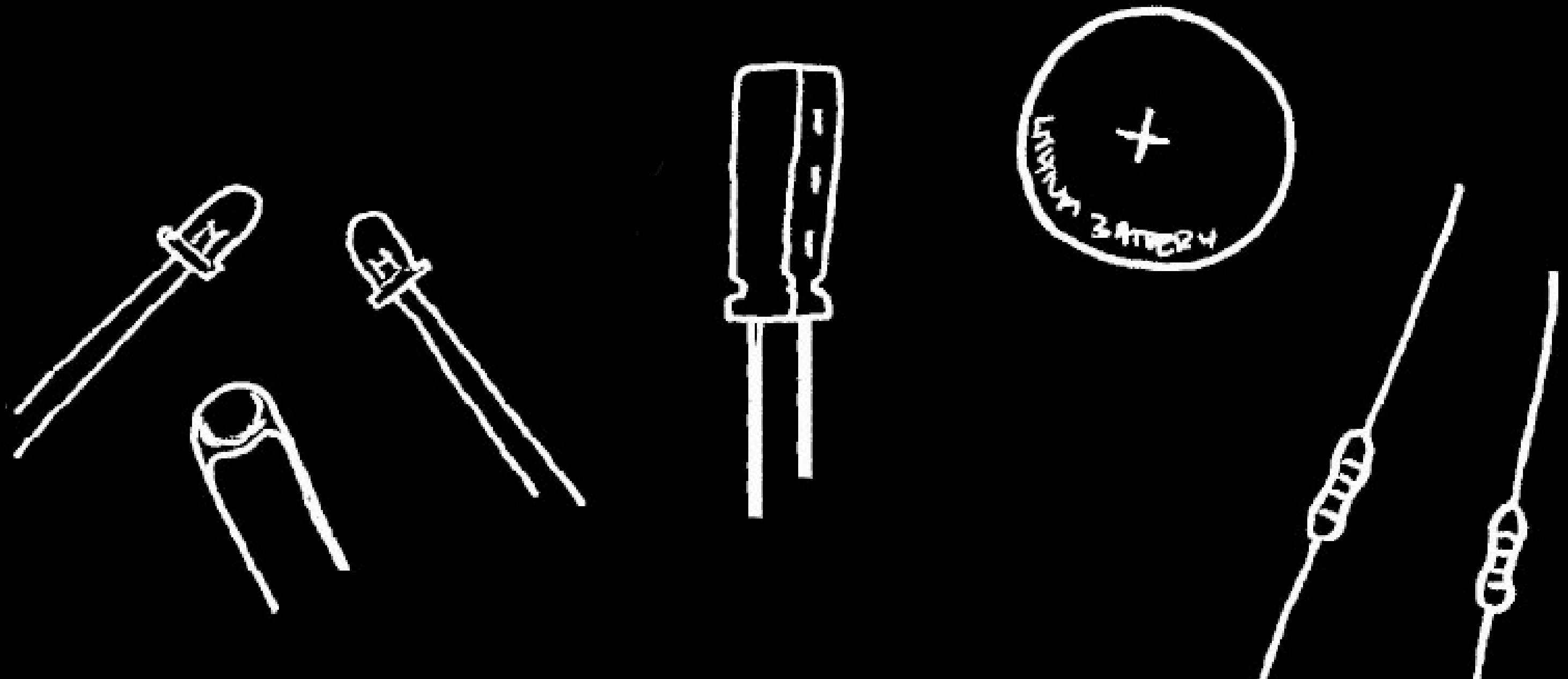

Learn To Solder



DOWNLOAD THIS COMIC BOOK AND
SHARE IT WITH YOUR FRIENDS!
[HTTP://MIGHTYOHM.COM/SOLDERCOMIC](http://mightyohm.com/soldercomic)

BY: MITCH ALTMAN
(SOLDERING WISDOM)
ANDIE NORDGREN
(COMICS ADAPTATION)
JEFF KEYZER
(LAYOUT AND EDITING)

CC BY SA
DISTRIBUTE WIDELY!

download for free at:
<http://mightyohm.com/soldercomic>

Learn To Solder

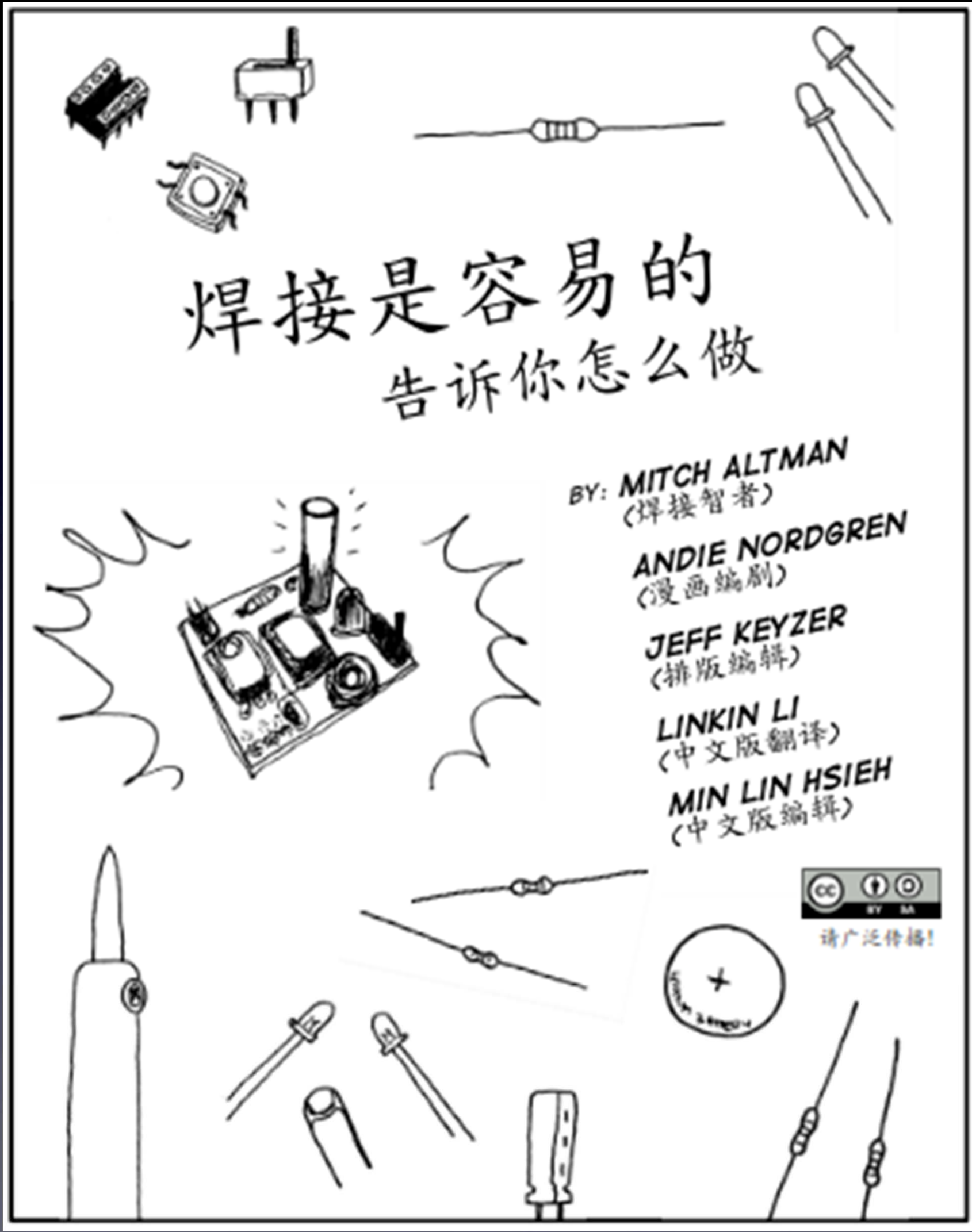

Download in the language of your choice for free at:
<http://mightyohm.com/soldercomic>

Learn To Solder



SOLDER C'EST FACILE

VOICI COMMENT FAIRE

DE: ***MITCH ALTMAN***
(MAITRE SOUDEUR)

ANDIE NORDGREN
(ADAPTATION BD)

JEFF KEYZER
(EDITION, MISE EN PAGE)

SNOOTLAB
(TRADUCTION FR.)

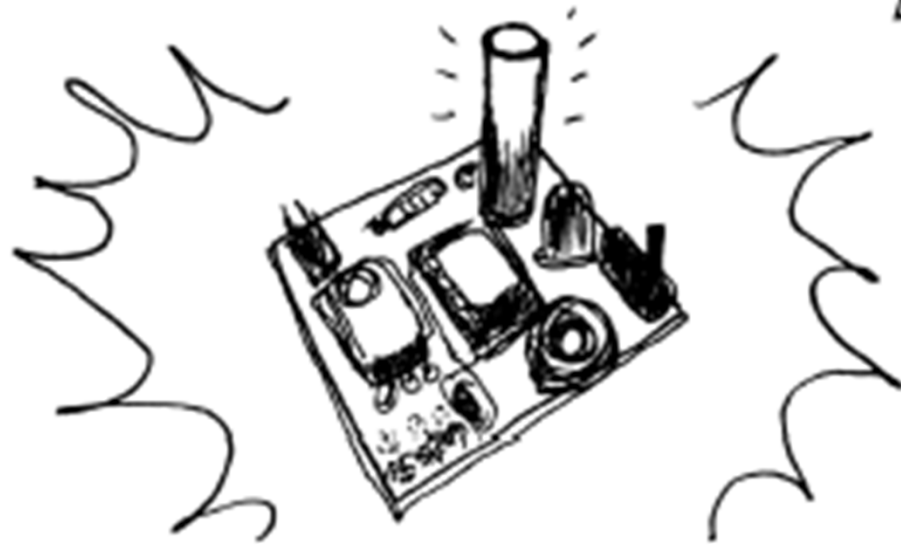

A DIFFUSER LARGEMENT !

TELECHARGEZ CETTE BD
ET PARTAGEZ LA AVEC VOS AMIS !
[HTTP://MIGHTYOHM.COM/SOLDERCOMIC](http://mightyohm.com/soldercomic)

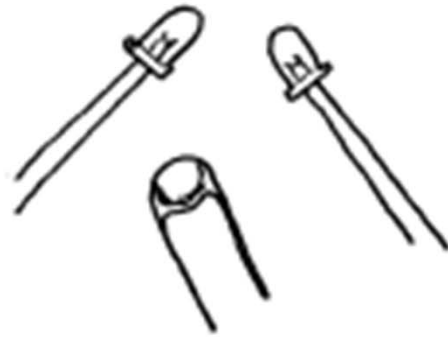

Download in the language of your choice for free at:
<http://mightyohm.com/soldercomic>

Learn To Solder

SOLDAR ES FÁCIL! *APRENDE CÓMO HACERLO*

POR: MITCH ALTMAN
(SABIDURÍA EN SOLDADO)

ANDIE NORDGREN
(ADAPTACIÓN A COMIC)

JEFF KEYZER
(DISEÑO Y EDICIÓN)



DISTRIBUYE AMPLIAMENTE!

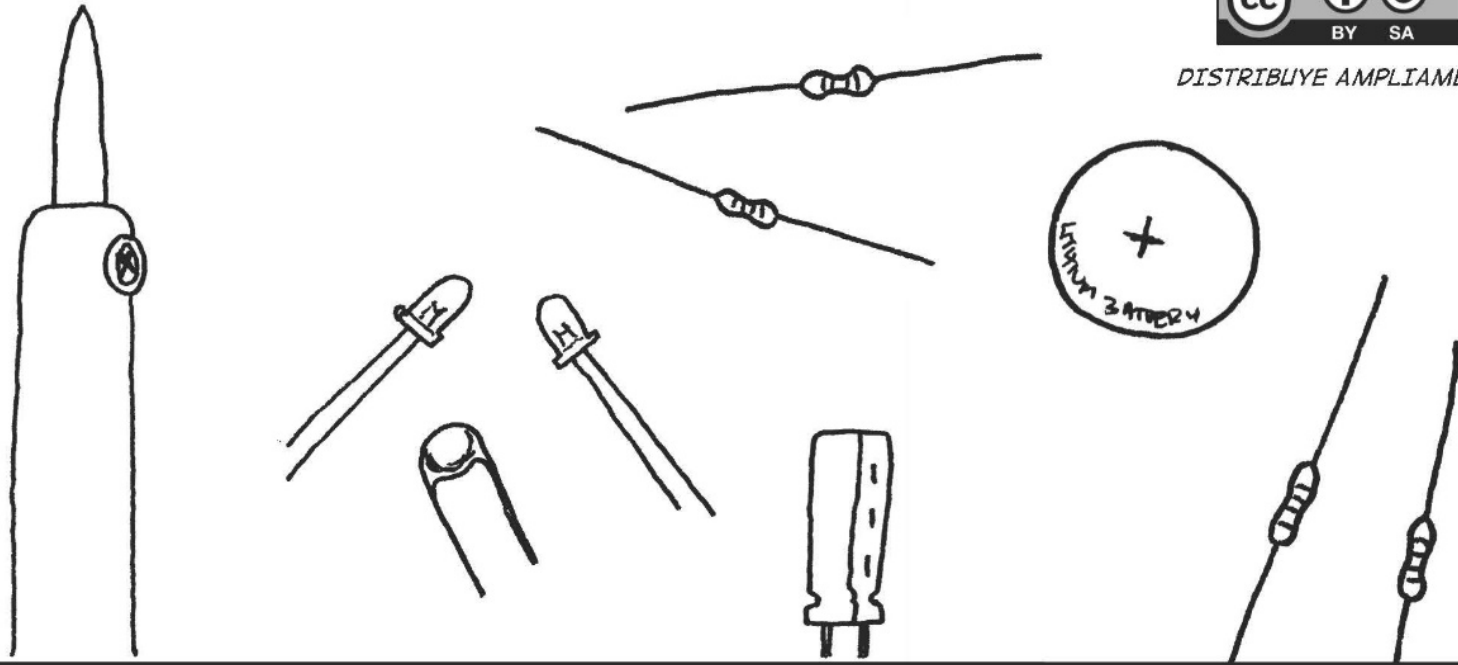
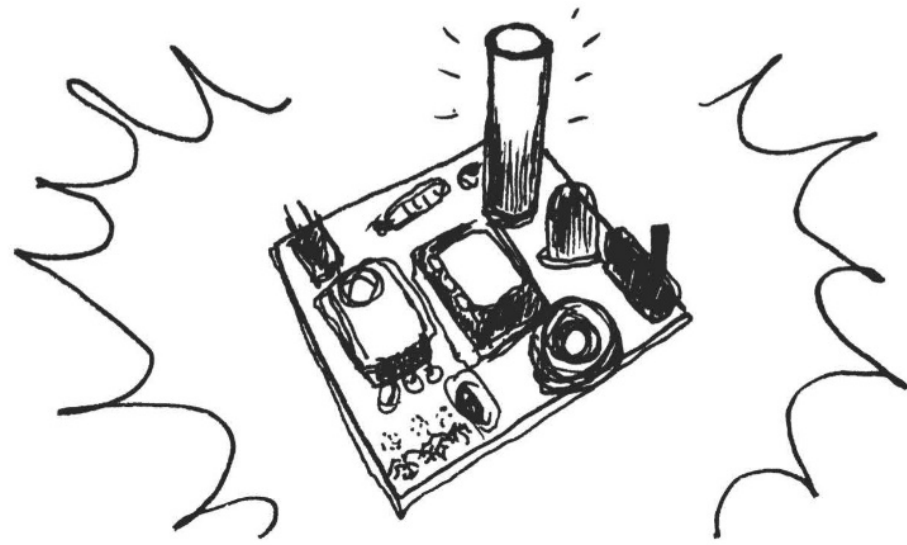
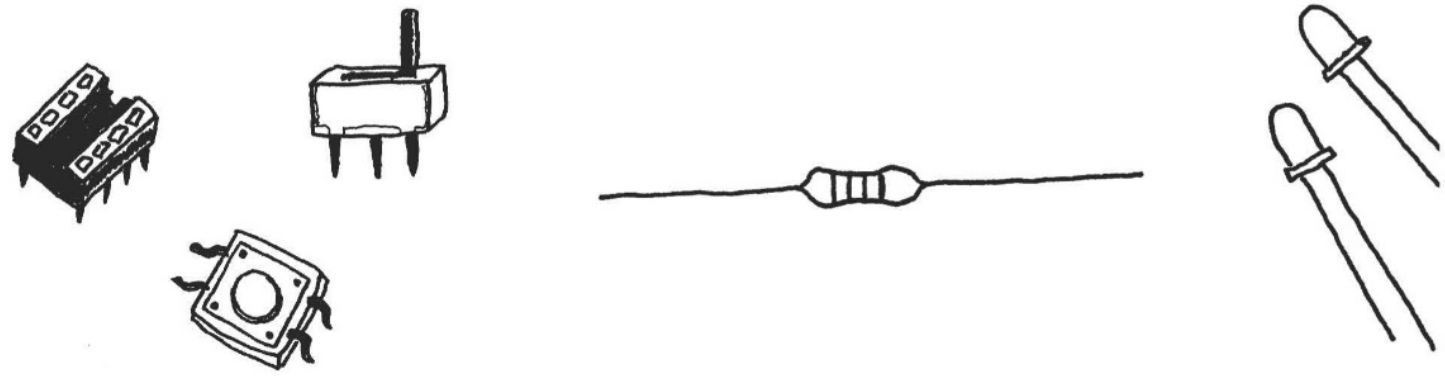

Download in the language of your choice for free at:
<http://mightyohm.com/soldercomic>

Learn To Solder



Download in the language of your choice for free at:

<http://mightyohm.com/soldercomic>

Solder Your Arduino Clone

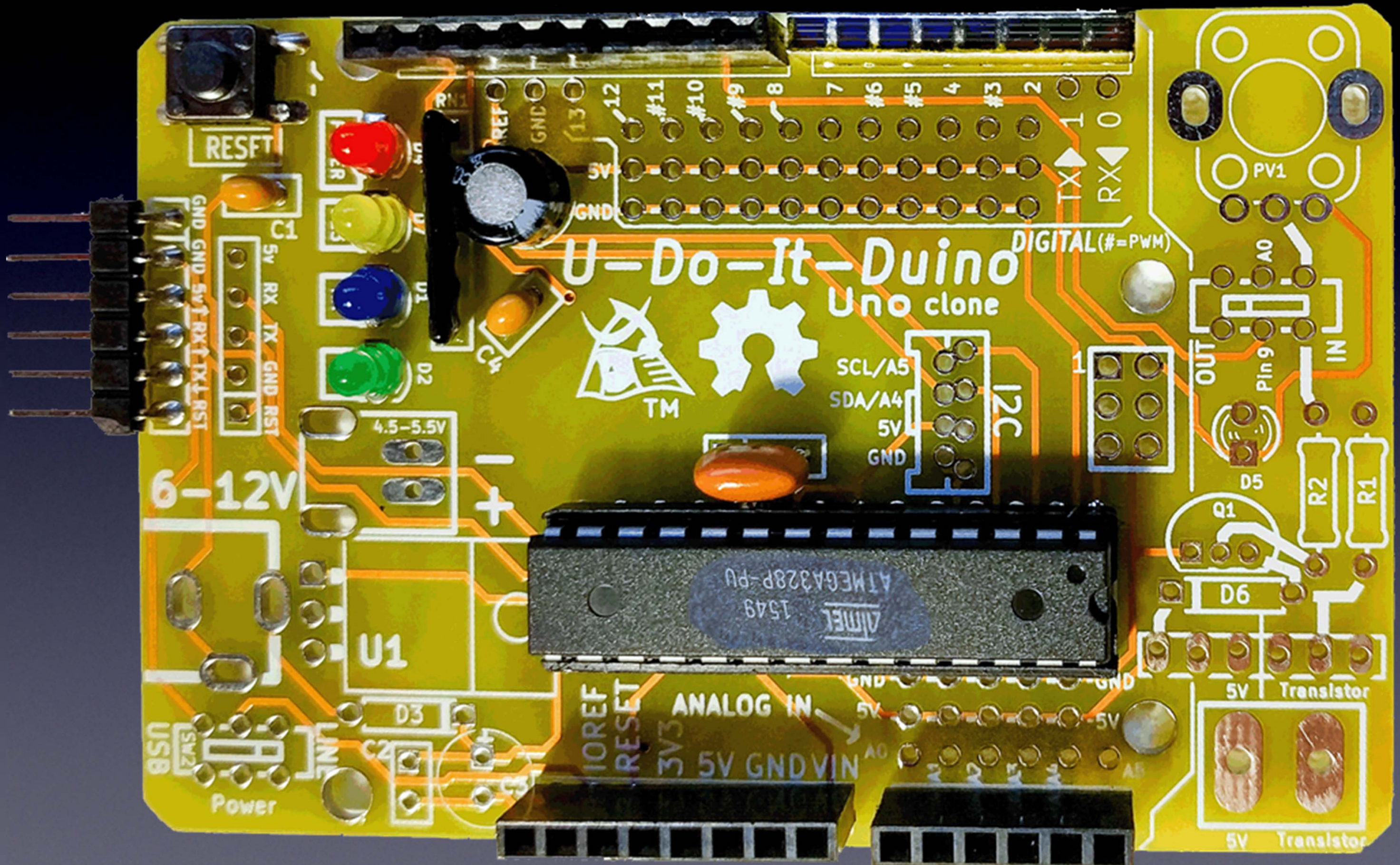

How to Set Up and Use the Arduino Software

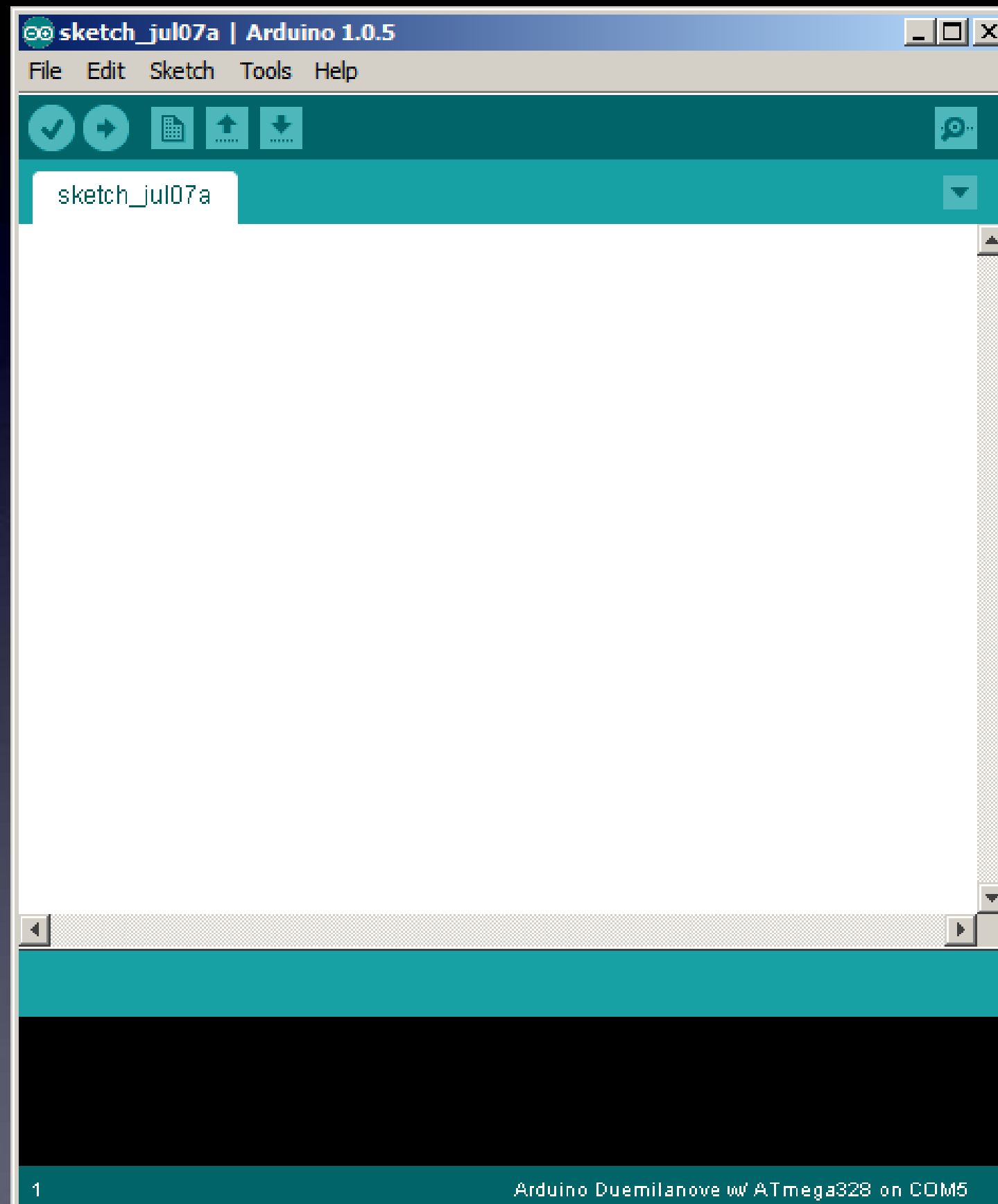

How to Hack Arduino Programs (“Sketches”)

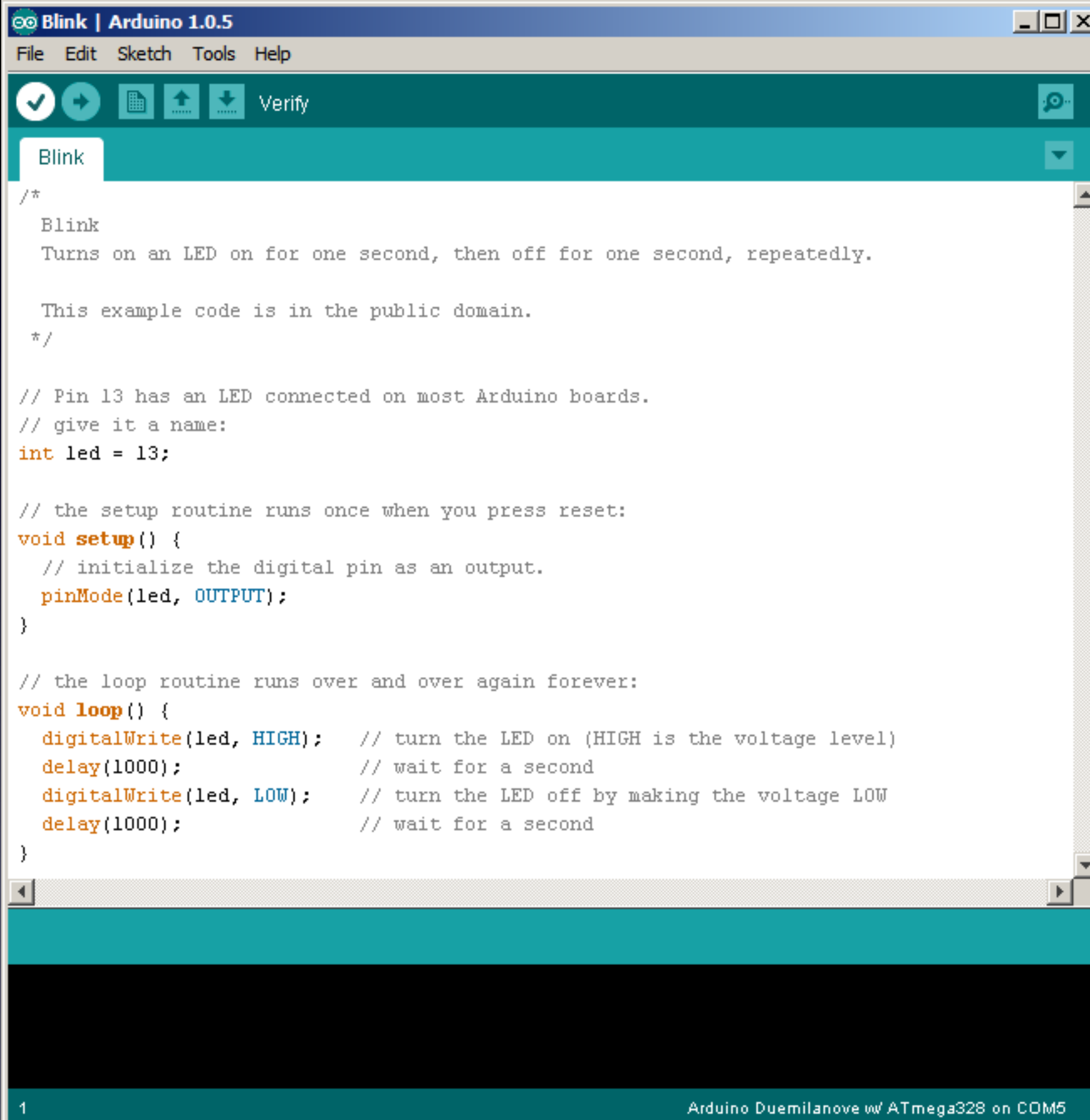
A screenshot of the Arduino IDE interface. The window title is "Blink | Arduino 1.0.5". The menu bar includes "File", "Edit", "Sketch", "Tools", and "Help". Below the menu bar is a toolbar with icons for a checkmark, a play button, a document, an upload arrow, a download arrow, and a "Verify" button. A tab labeled "Blink" is active. The main text area contains the following code:

```
/*  
  Blink  
  Turns on an LED on for one second, then off for one second, repeatedly.  
  
  This example code is in the public domain.  
  */  
  
// Pin 13 has an LED connected on most Arduino boards.  
// give it a name:  
int led = 13;  
  
// the setup routine runs once when you press reset:  
void setup() {  
  // initialize the digital pin as an output.  
  pinMode(led, OUTPUT);  
}  
  
// the loop routine runs over and over again forever:  
void loop() {  
  digitalWrite(led, HIGH); // turn the LED on (HIGH is the voltage level)  
  delay(1000);             // wait for a second  
  digitalWrite(led, LOW);  // turn the LED off by making the voltage LOW  
  delay(1000);             // wait for a second  
}
```

The status bar at the bottom shows "1" on the left and "Arduino Duemilanove w/ ATmega328 on COM5" on the right.

How to Use Solderless Breadboards

Solderless Breadboard

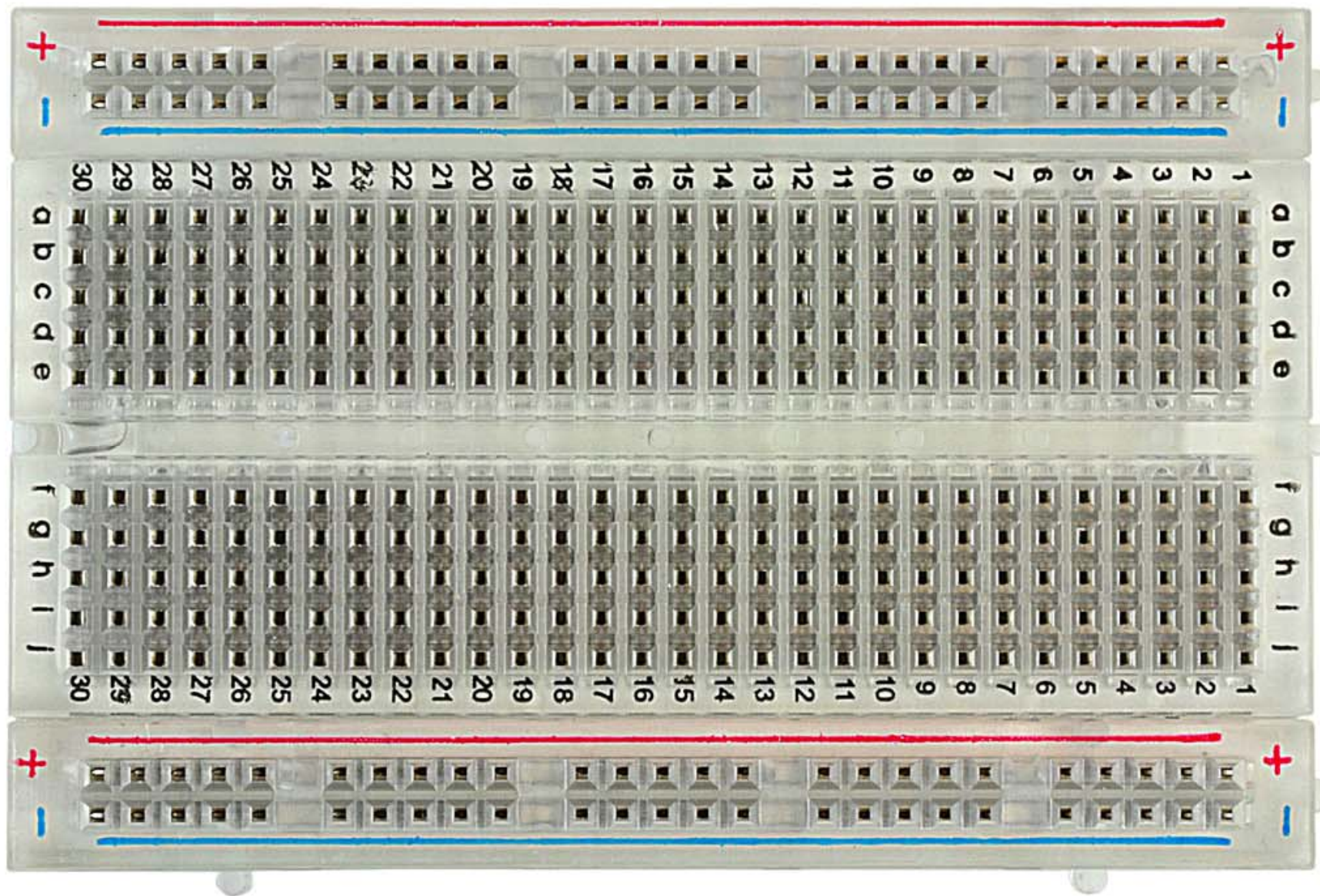

How to Use Solderless Breadboards

Solderless Breadboard with LED and wires

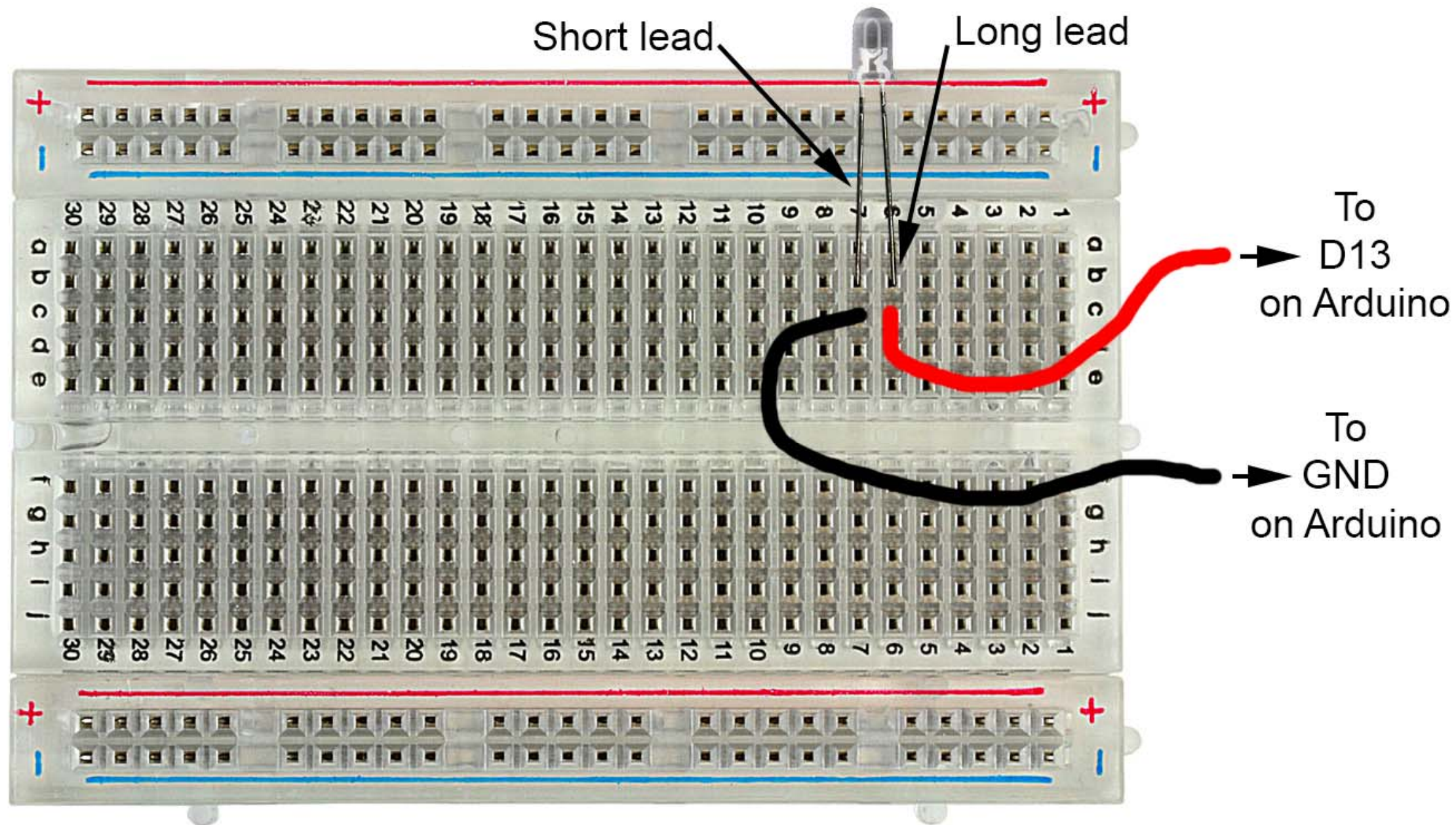

How to Read a Schematic

Arduino For Total Newbies

4-Sep-2015

Mitch Altman (original TV-B-Gone hardware and firmware, modified TV-B-Gone Arduino design)
Limore Fried (firmware modifications, kit design)
Ken Shirriff (original modifications for Arduino)
Johannes Schneemann (documentation)

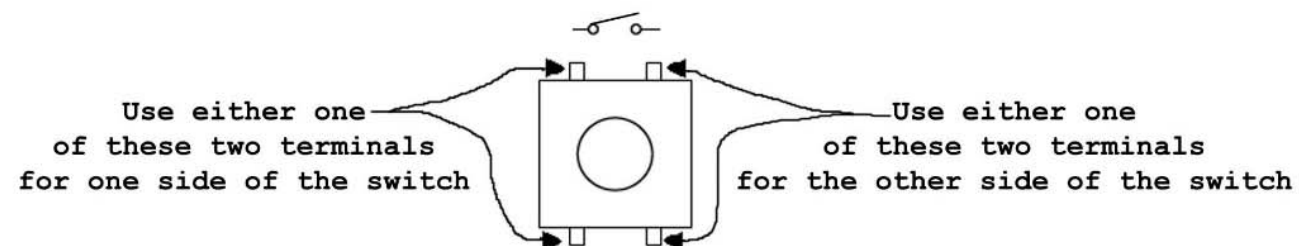
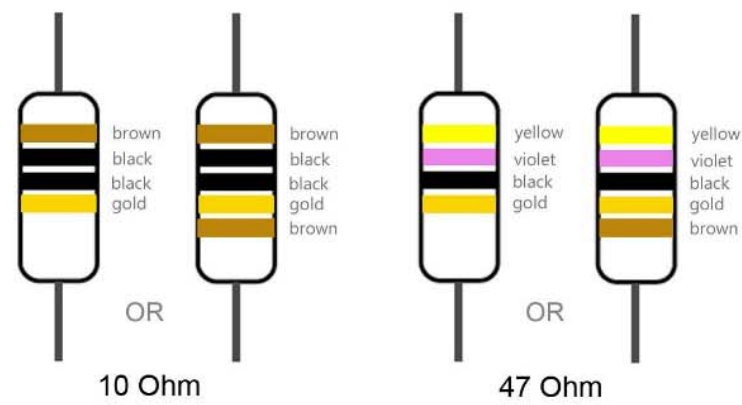
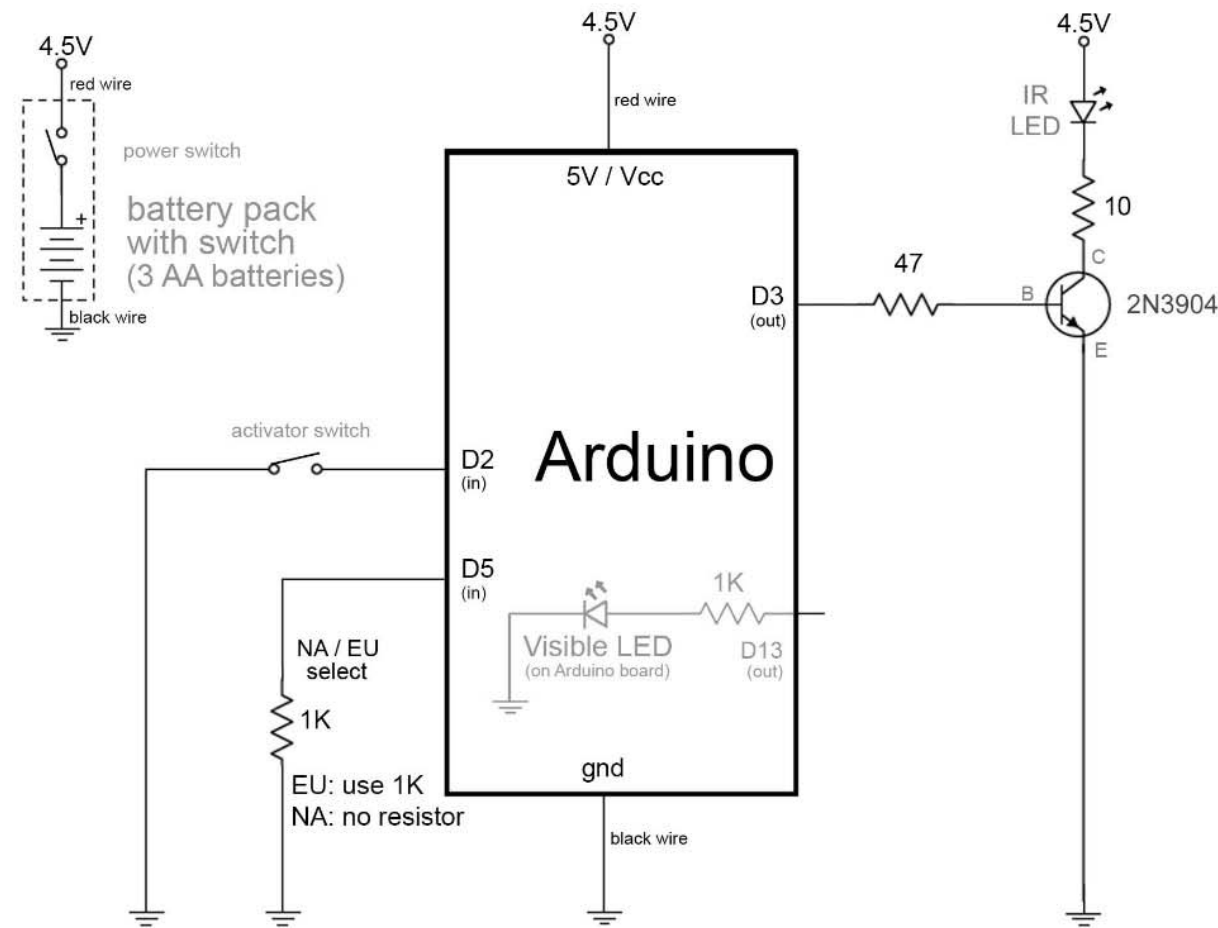

Make a TV-B-Gone Remote Control with your Arduino Clone without soldering

Solderless Breadboard with parts & wires for TV-B-Gone

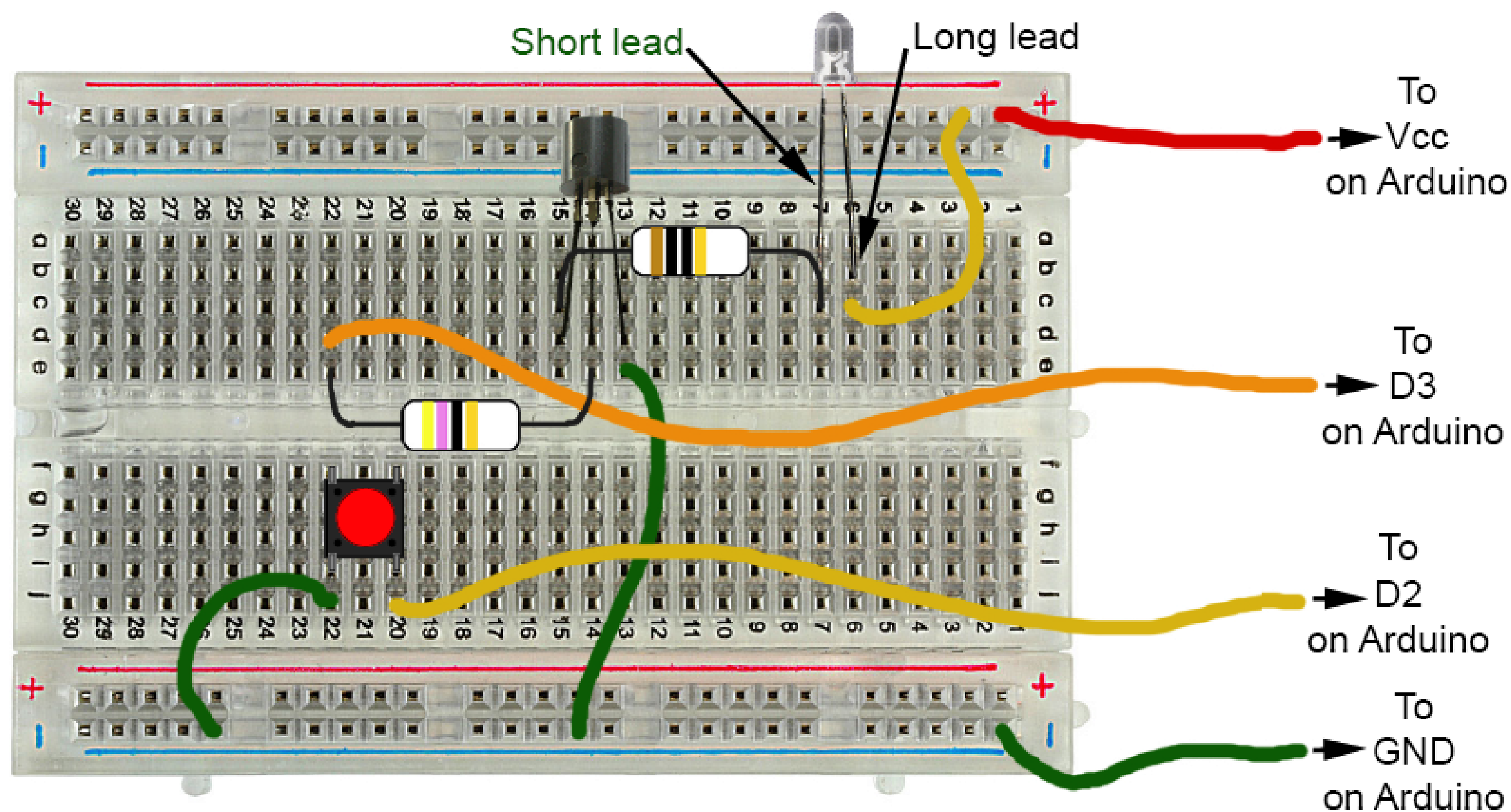

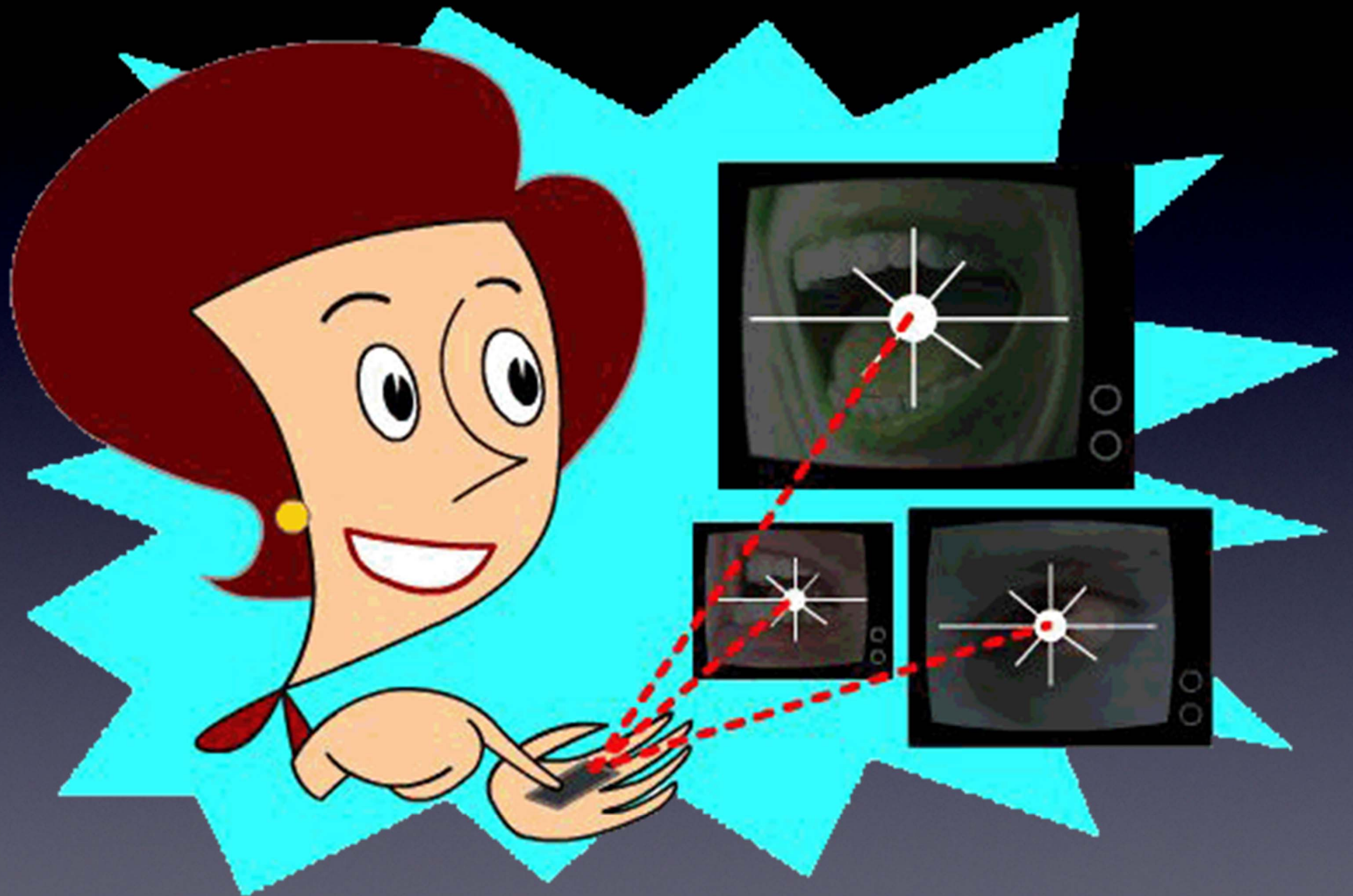

Questions?

Intro



Intro

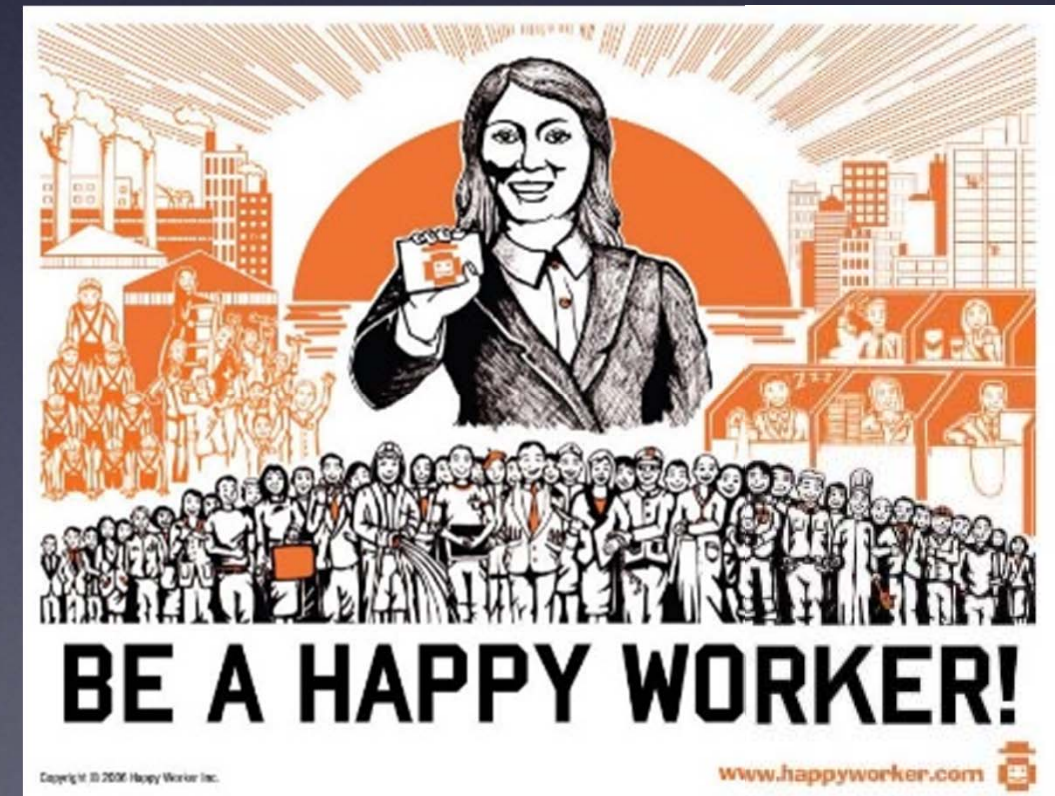

Intro

Cornfield
 *Electronics, Inc.*

MITCH ALTMAN

Chief Scientist / CEO

“Useful Electronics for a Better World”



www.CornfieldElectronics.com

572 Hill St. #Penthouse, San Francisco, CA 94114

phone: +1 415 / 377 - 5993

mitch@CornfieldElectronics.com

@maltman23

Intro



Arduino For Total Newbies Workshop at 30C3, Hamburg Germany

Intro to Arduino



Intro to Arduino: microcontrollers

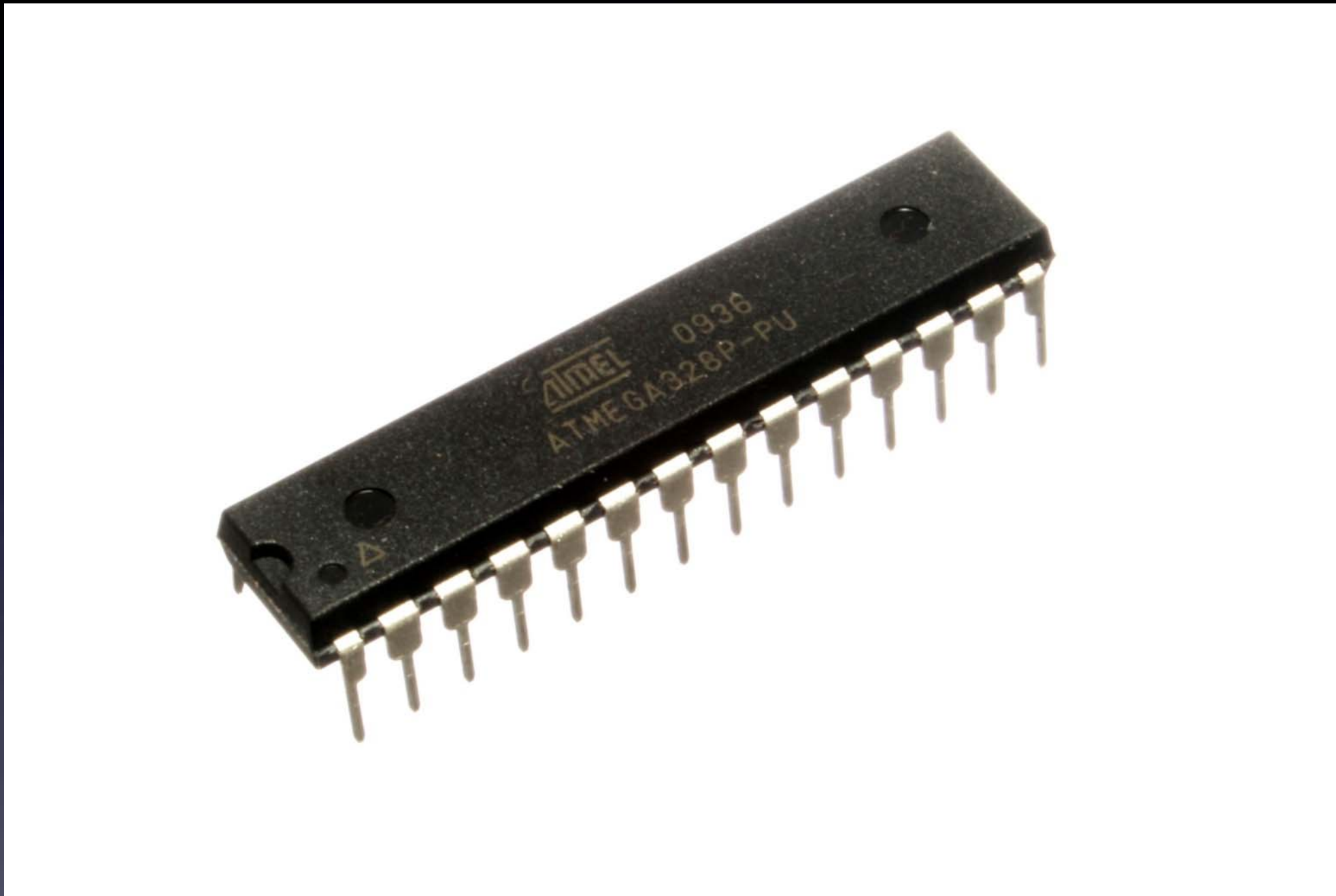

A complete computer on a chip

Intro to Arduino: microcontrollers

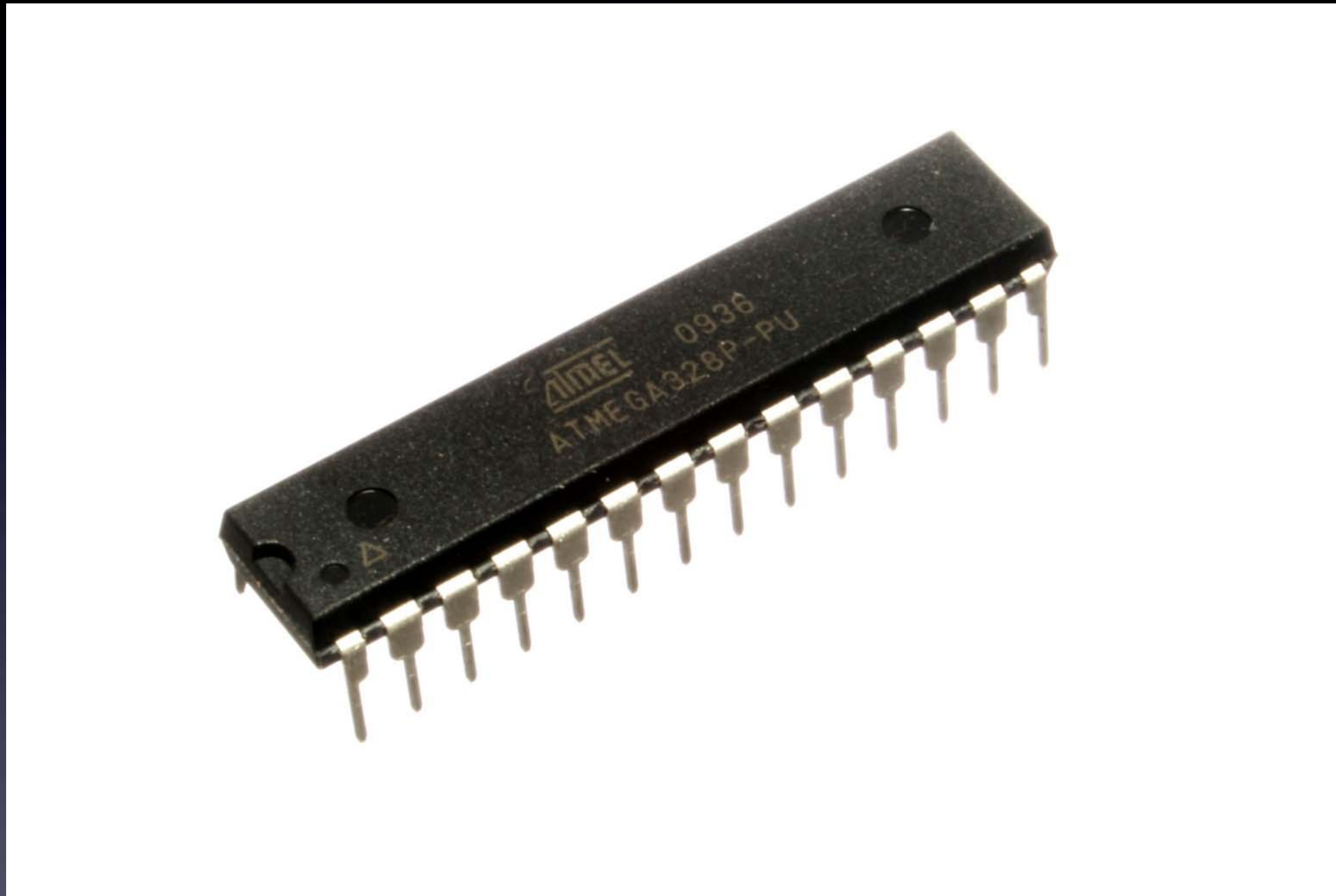

A complete computer on a chip:
they control parts connected to their pins

Intro to Arduino: microcontrollers

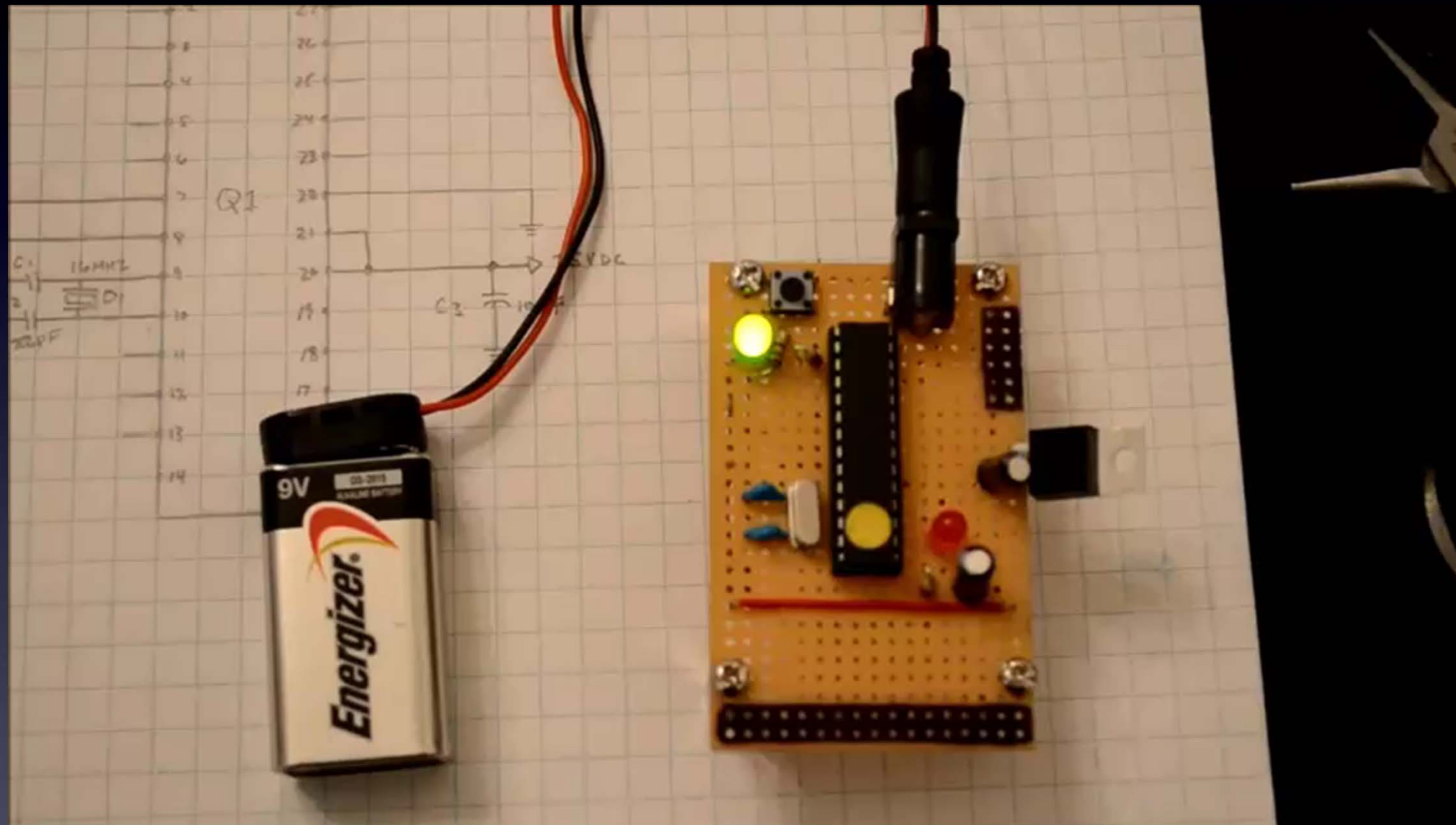

Intro to Arduino:
microcontrollers
-- some of Mitch's projects --

Trippy RGB Waves kit

Intro to Arduino: microcontrollers

-- some of Mitch's projects --

*ArduTouch
music
synthesizer
kit*

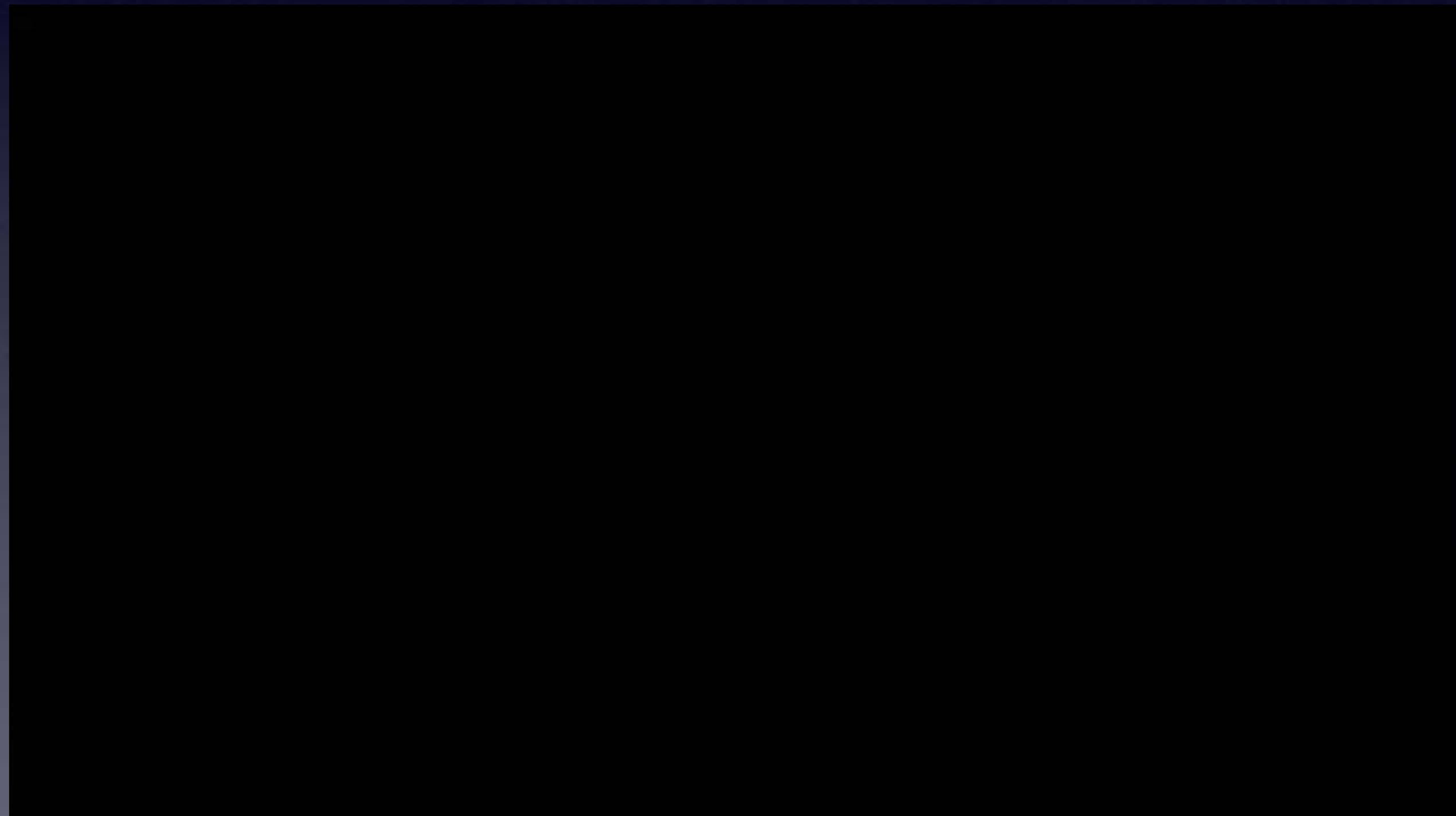

Intro to Arduino: microcontrollers



Intro to Arduino: microcontrollers



Intro to Arduino: microcontrollers



Intro to Arduino: microcontrollers



Intro to Arduino: microcontrollers

-- some of Mitch's projects --

TV-B-Gone



Intro to Arduino: microcontrollers

-- some of Mitch's projects --



TV-B-Gone

*Just a remote control,
but only one button:*

OFF !



Intro to Arduino: microcontrollers

-- some of Mitch's projects --



TV-B-Gone

Intro to Arduino: microcontrollers

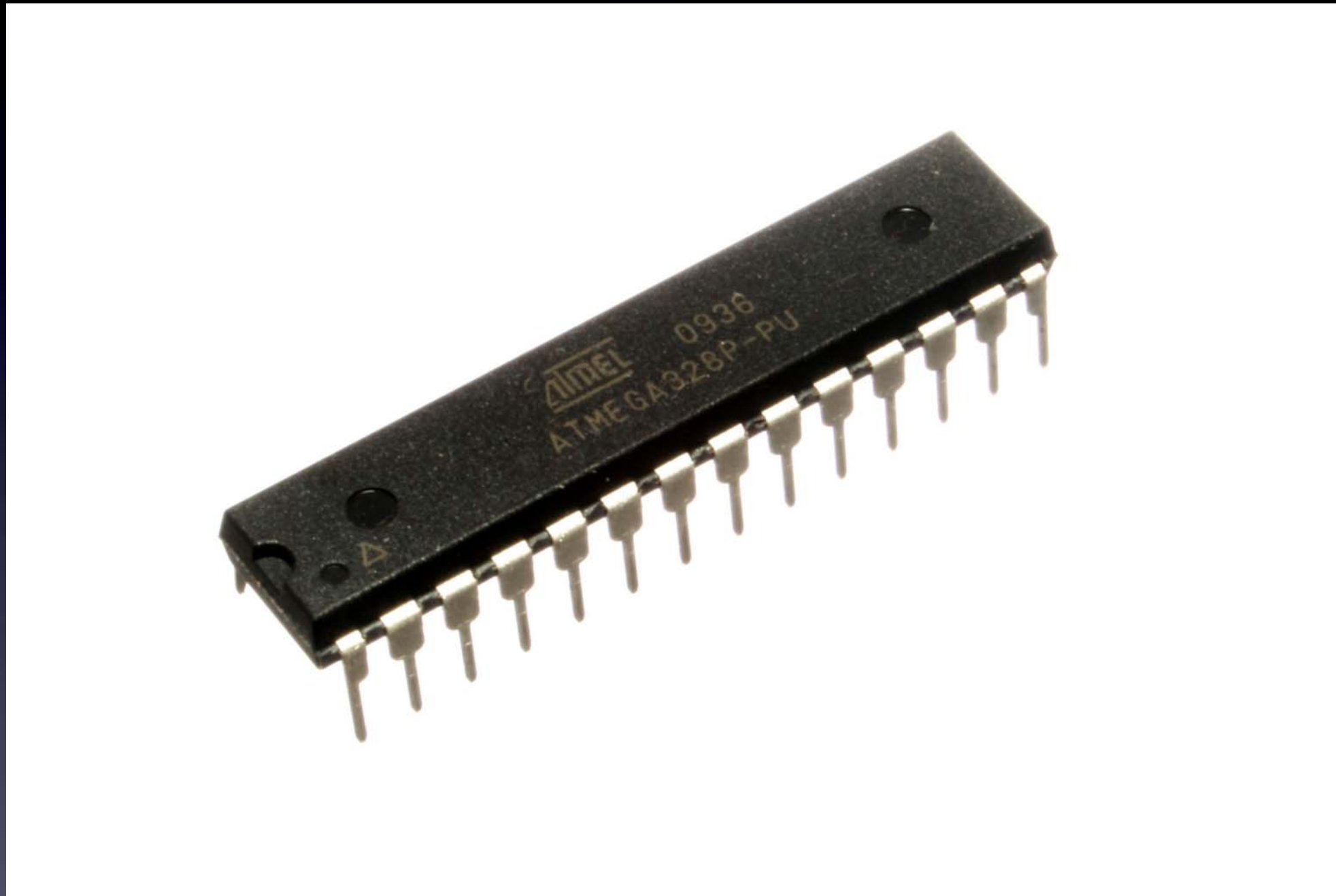

A complete computer on a chip:
they control parts connected to their pins

Intro to Arduino: microcontrollers

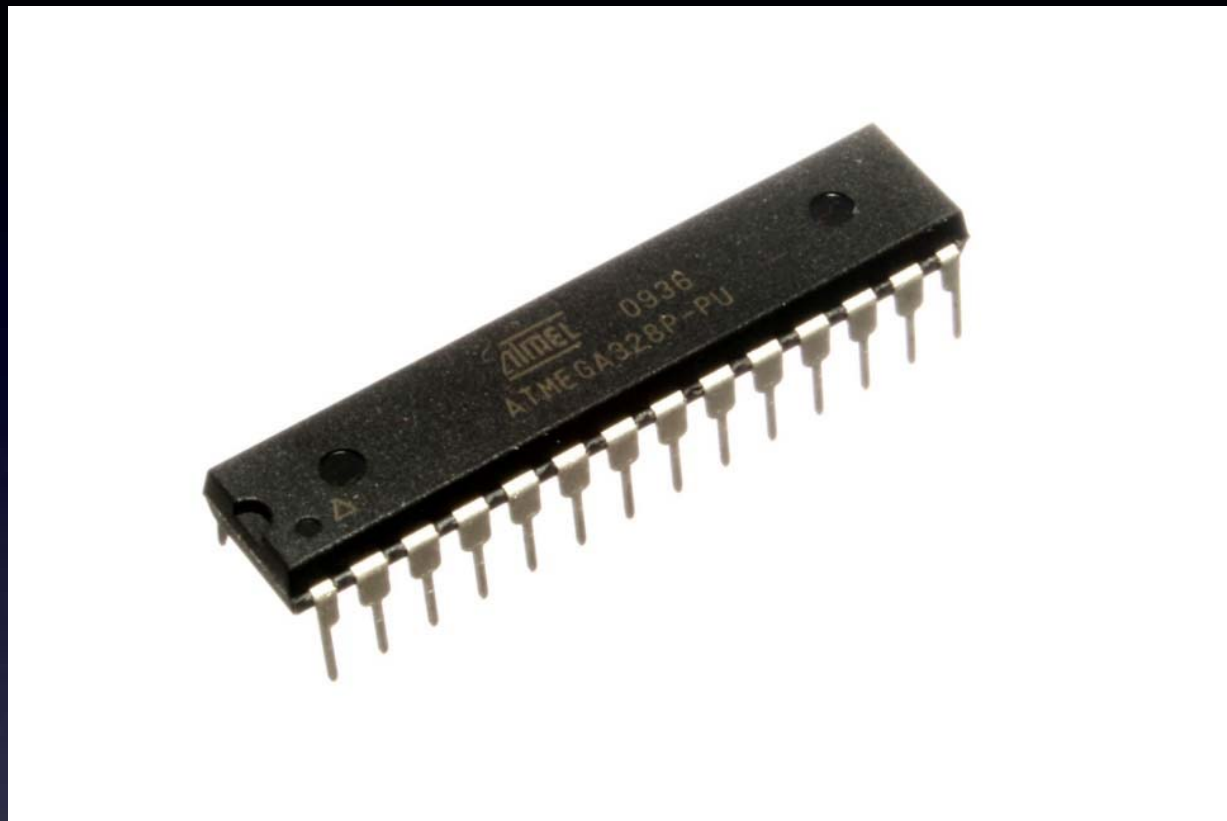

A complete computer on a chip:

they control parts connected to their pins

But,

How do you
connect parts to its pins?

How do you
create and upload a program
to control the parts?

Intro to Arduino: microcontrollers

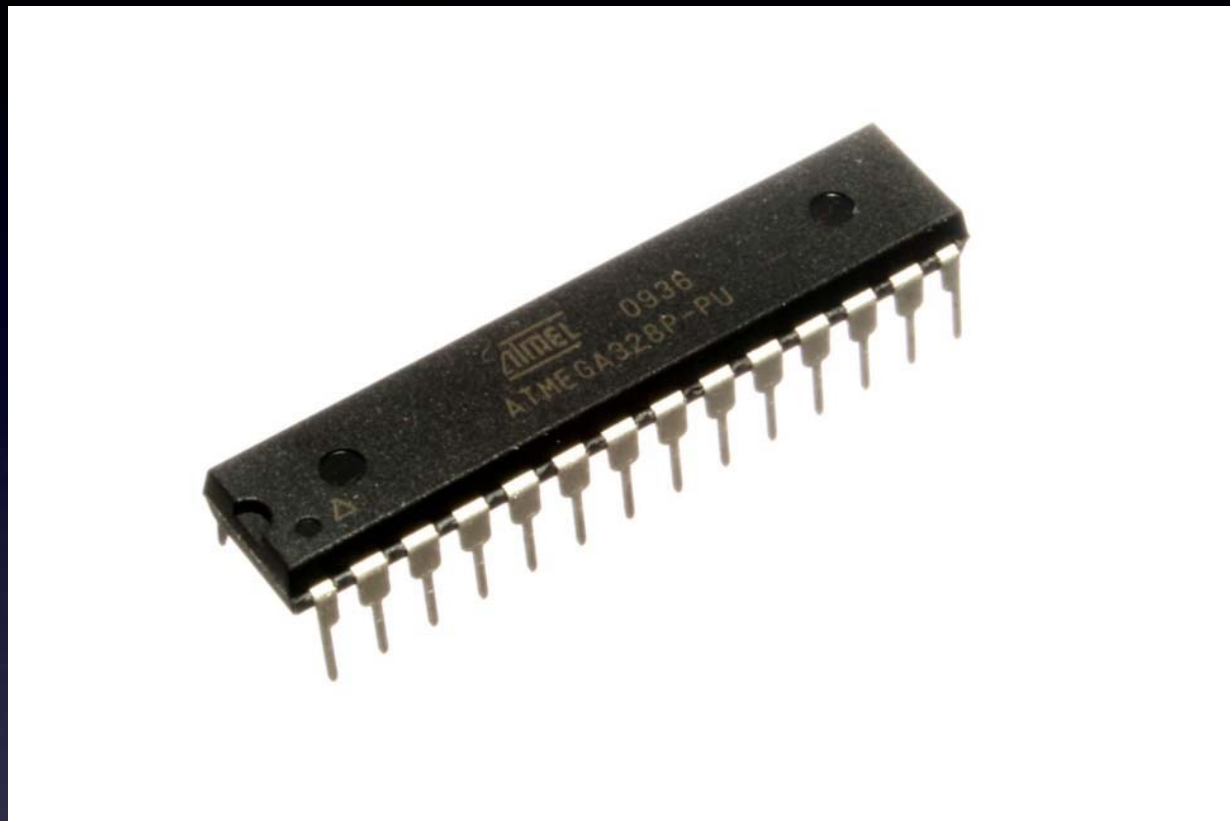

A complete computer on a chip:

they control parts connected to their pins

But,

How do you
connect parts to its pins?

How do you
create and upload a program
to control the parts?

Answer: Be a geek, and learn how!

Or

Intro to Arduino



Use an Arduino board

Intro to Arduino



Use an Arduino board

Super easy to connect parts to its microcontroller's pins

Super easy to create and upload a program to control the parts

Intro to Arduino

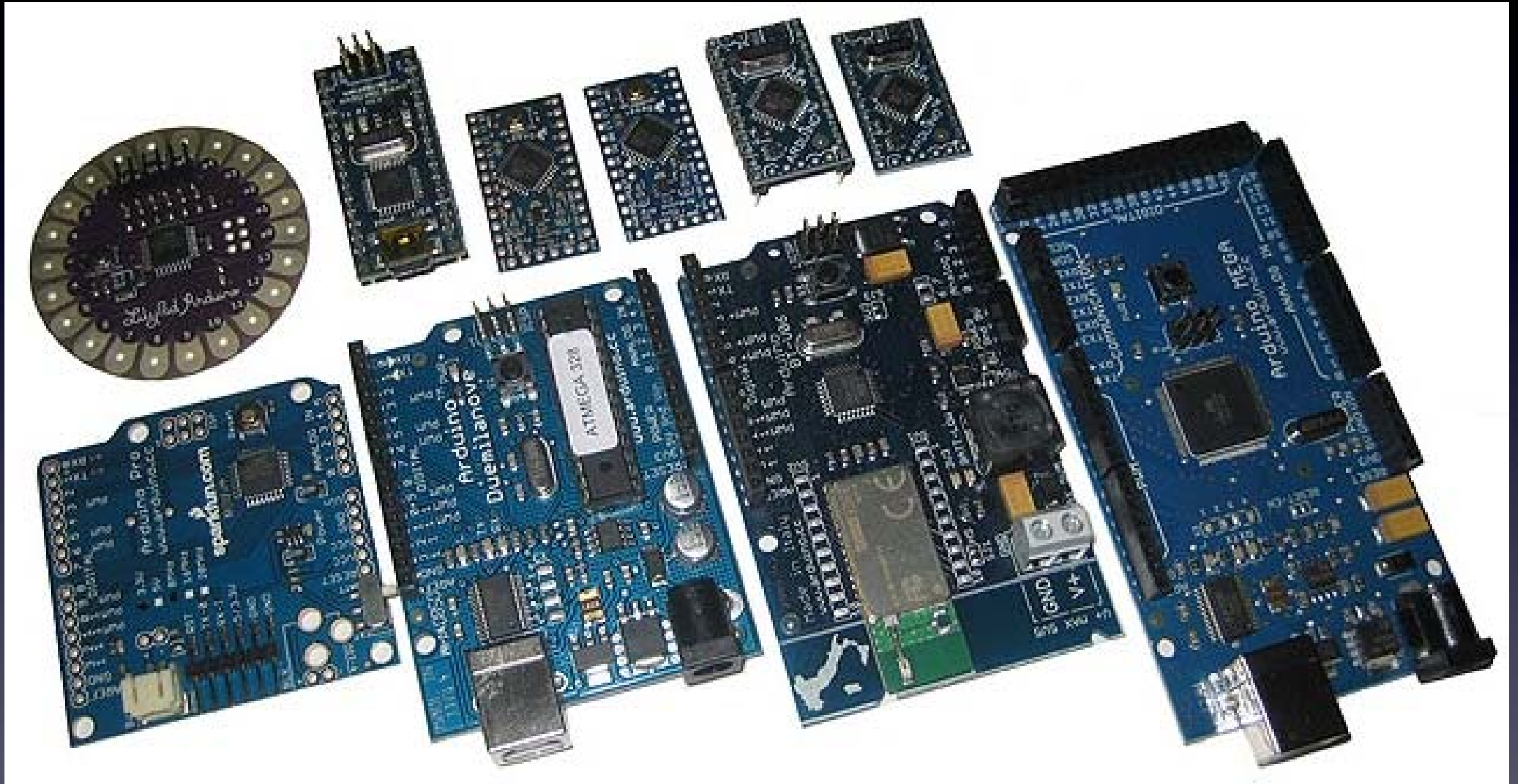

Many Arduino boards to choose from

Intro to Arduino

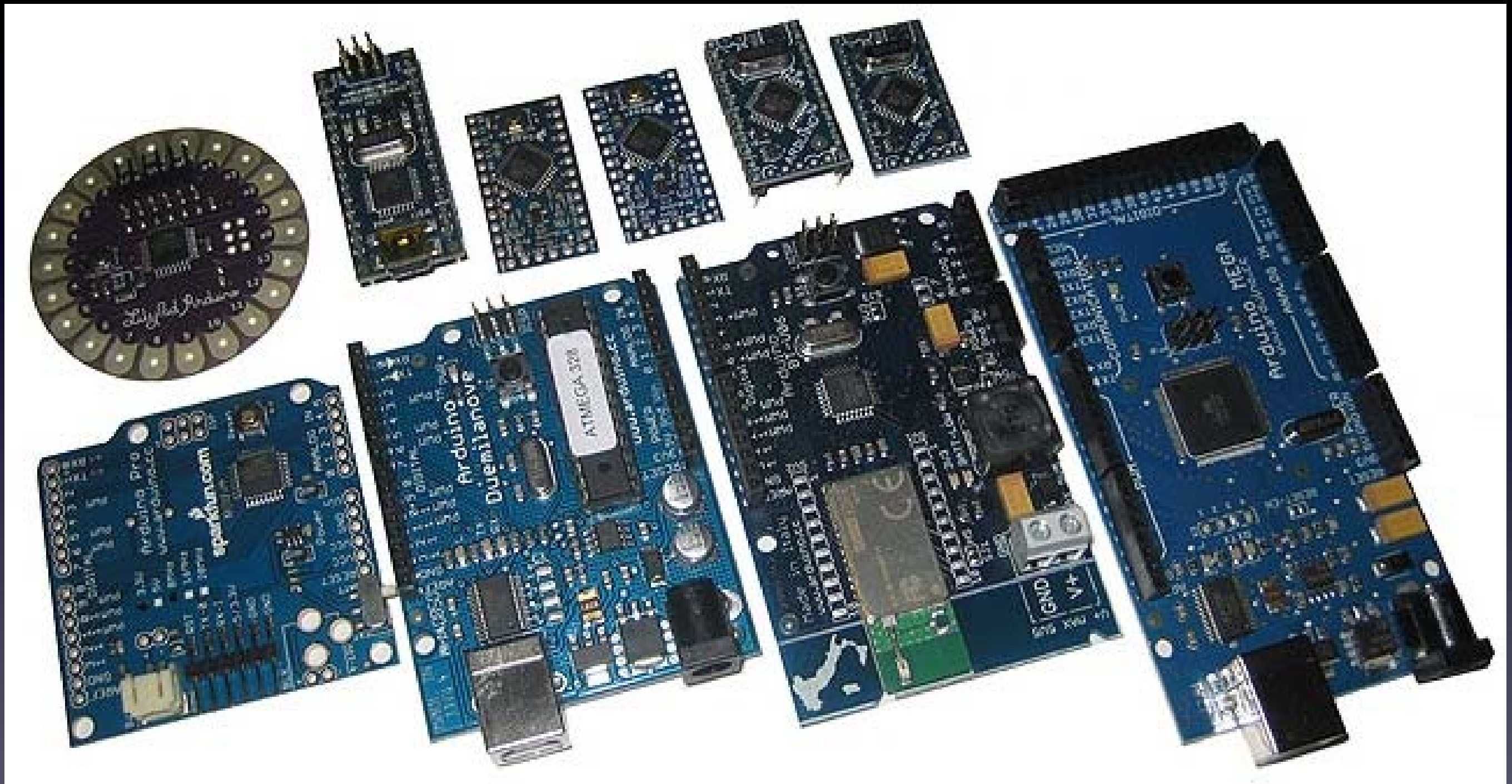

Open Source

Intro to Arduino

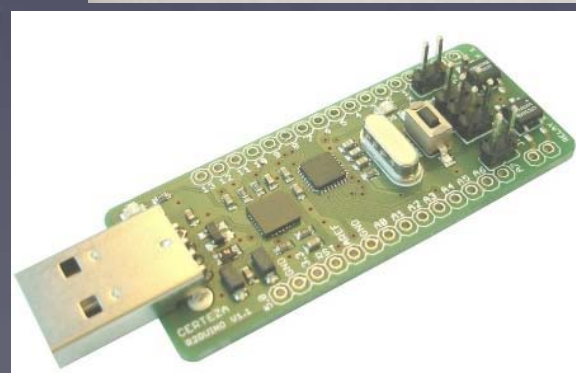
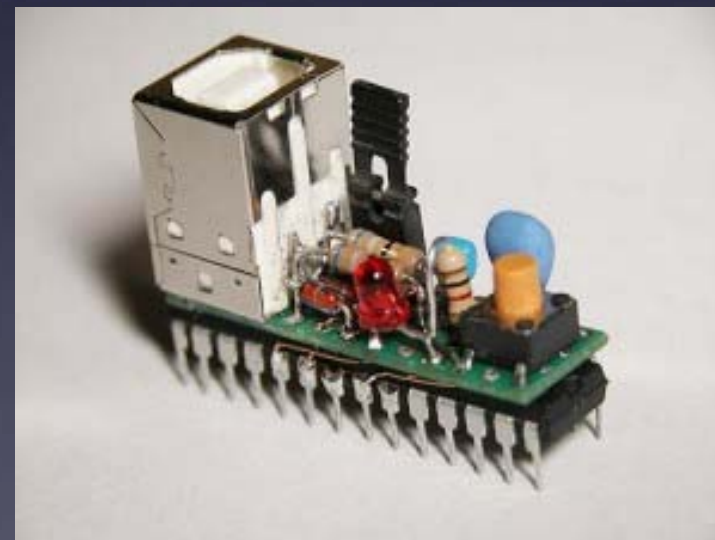
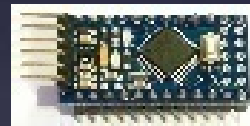
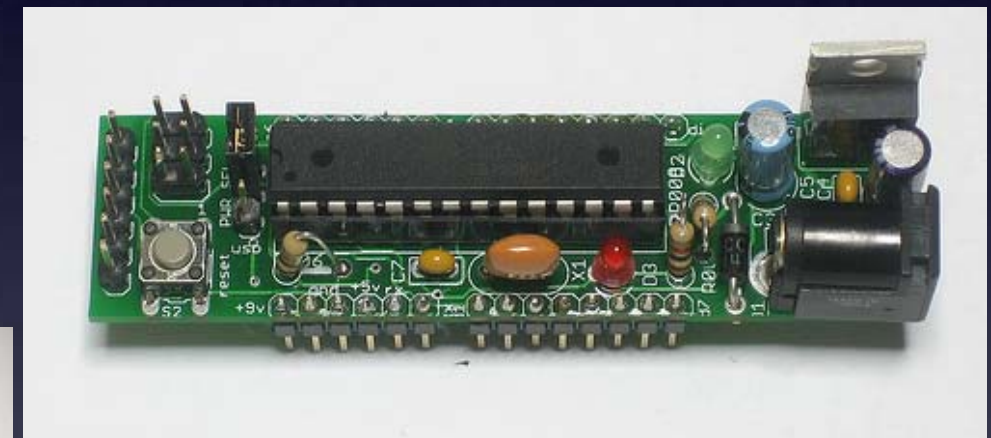
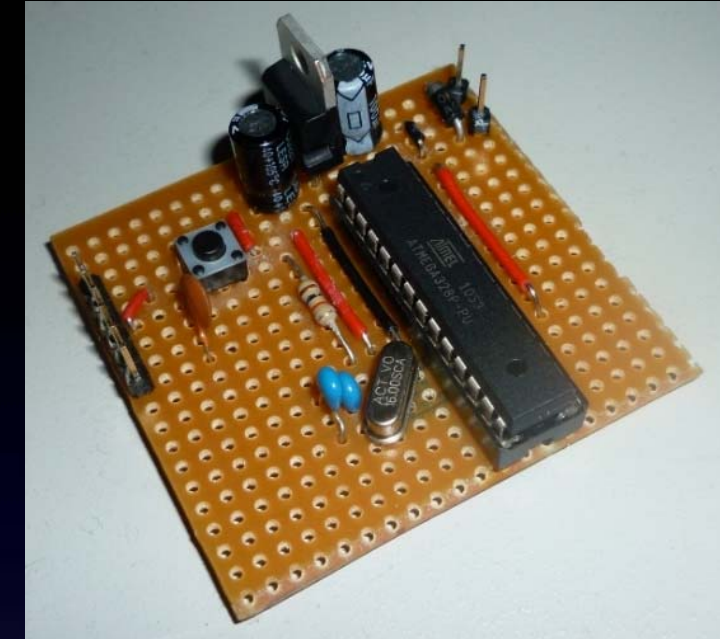
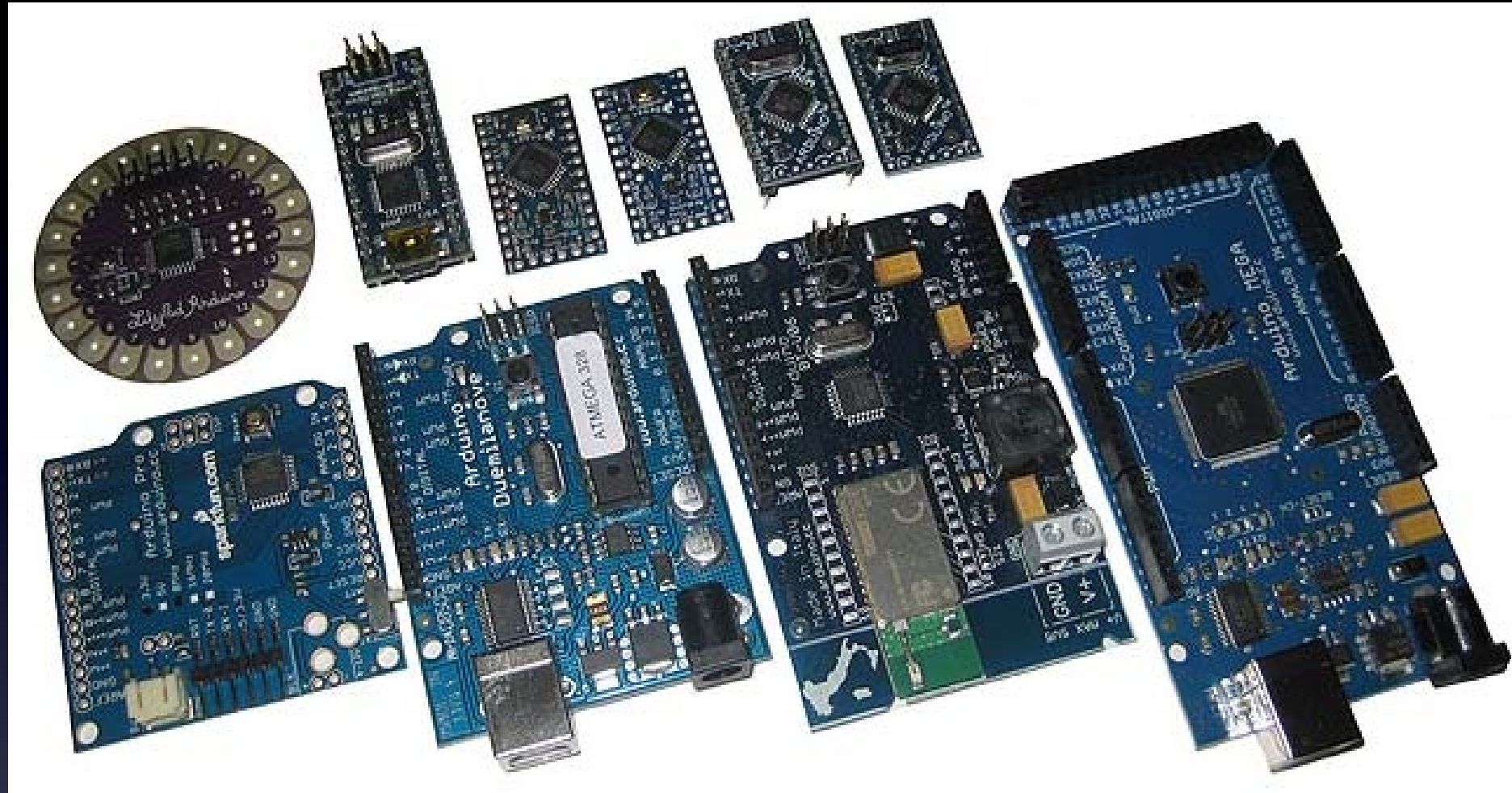

Open Source

Intro to Arduino

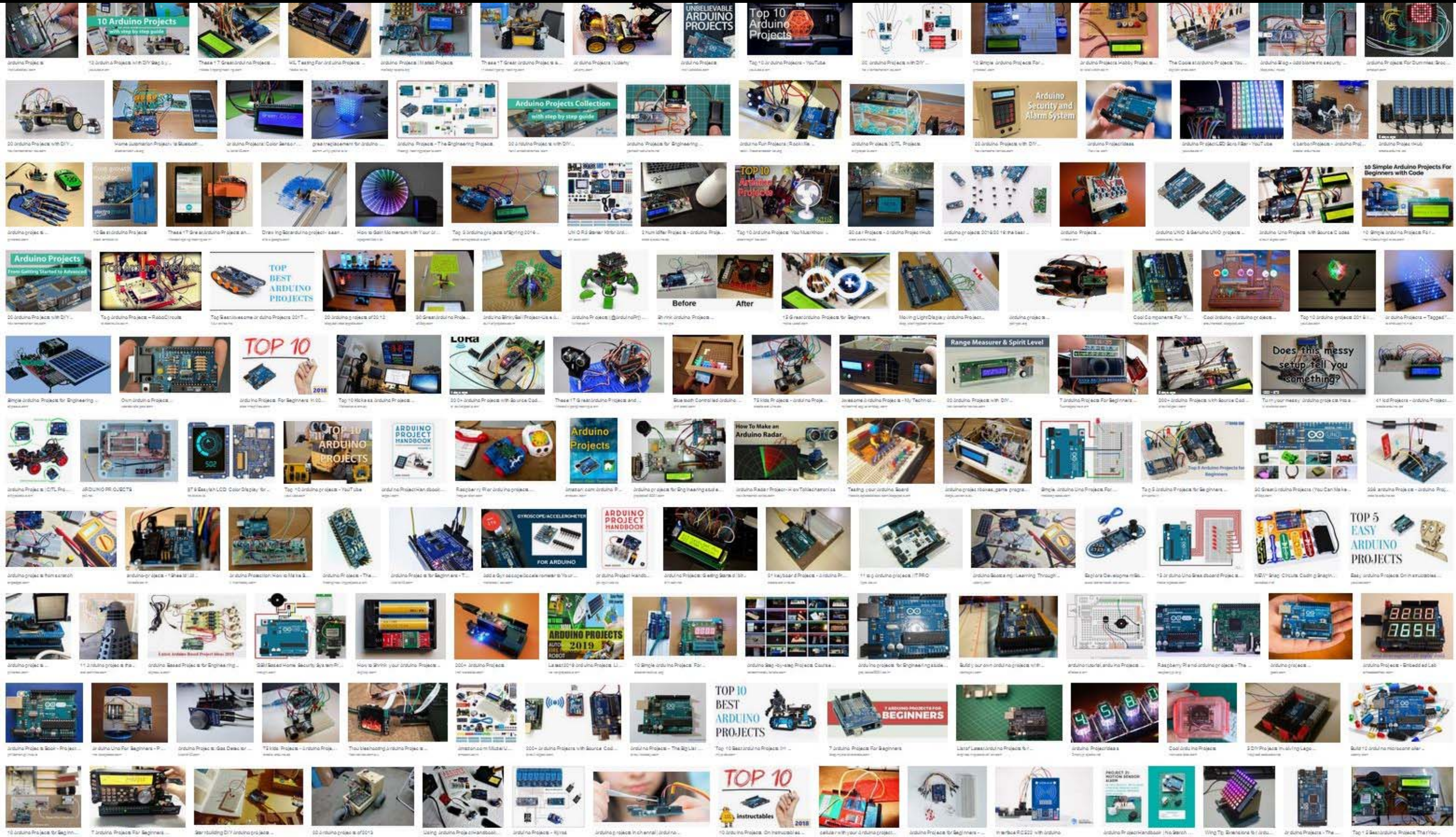

hundreds of thousands of projects online!

Intro to Arduino

“Arduino-Compatible”

*ArduTouch
music
synthesizer
kit*

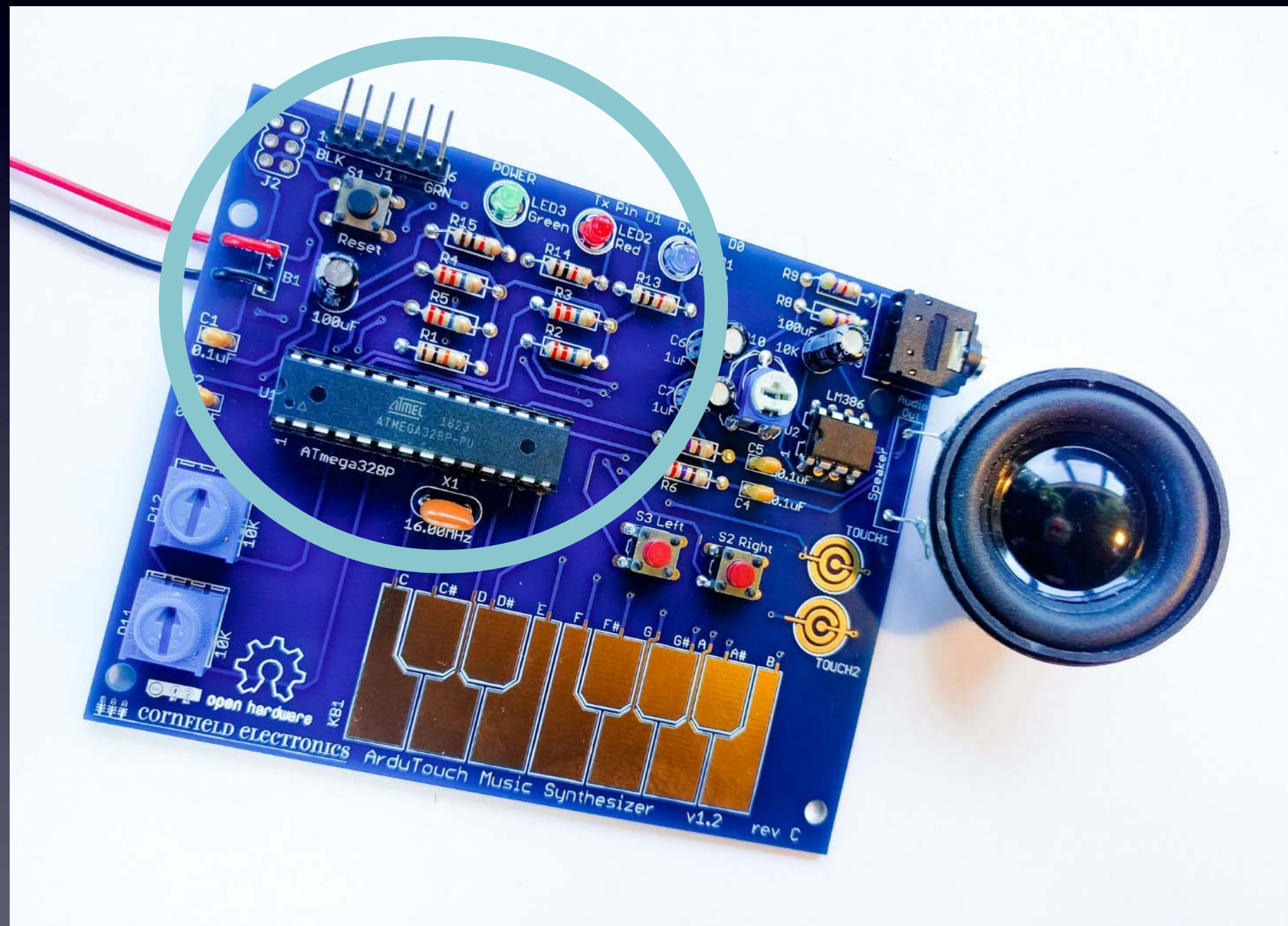

Intro

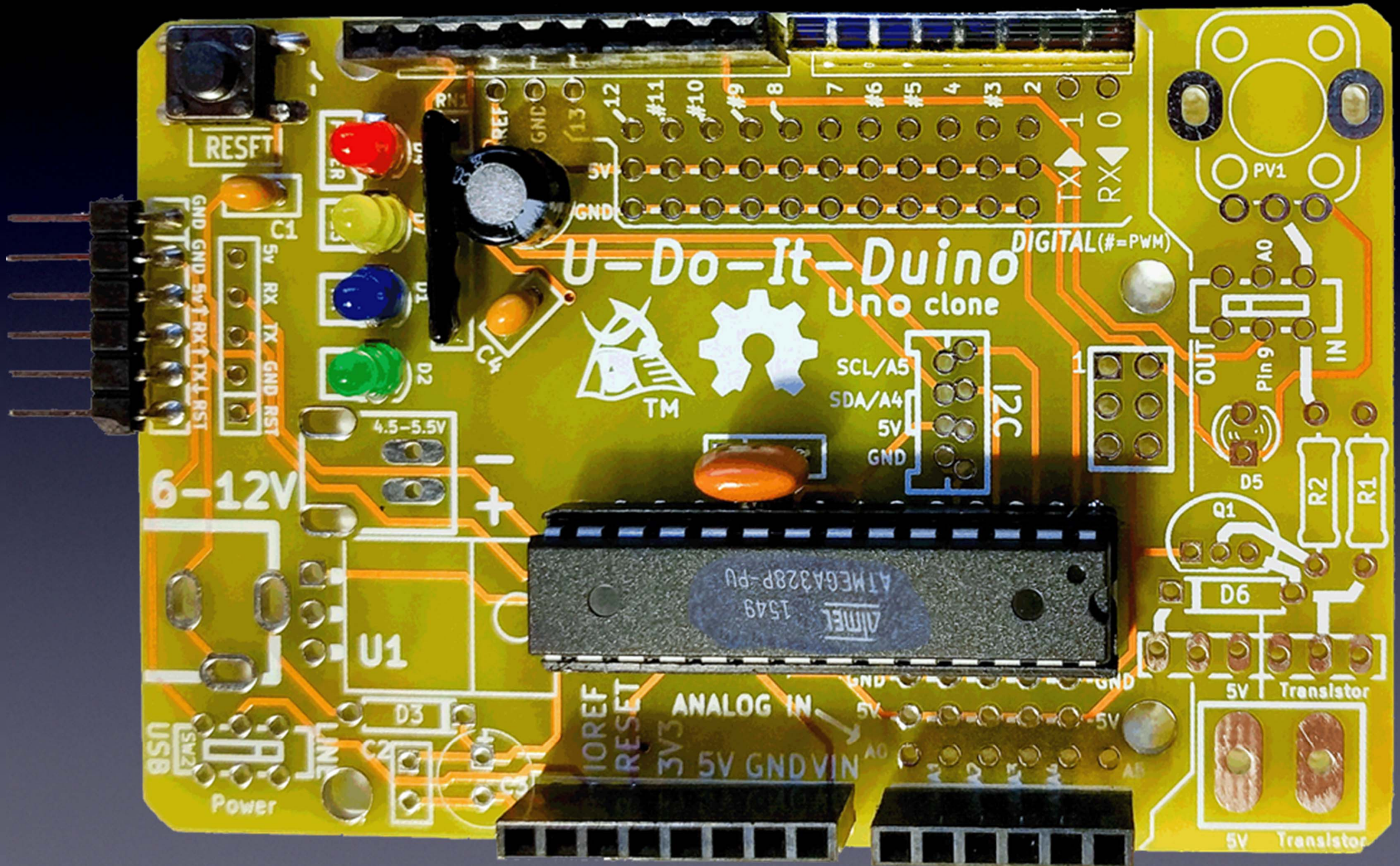

Intro

Questions?

Everything You Need to Know About Electronics

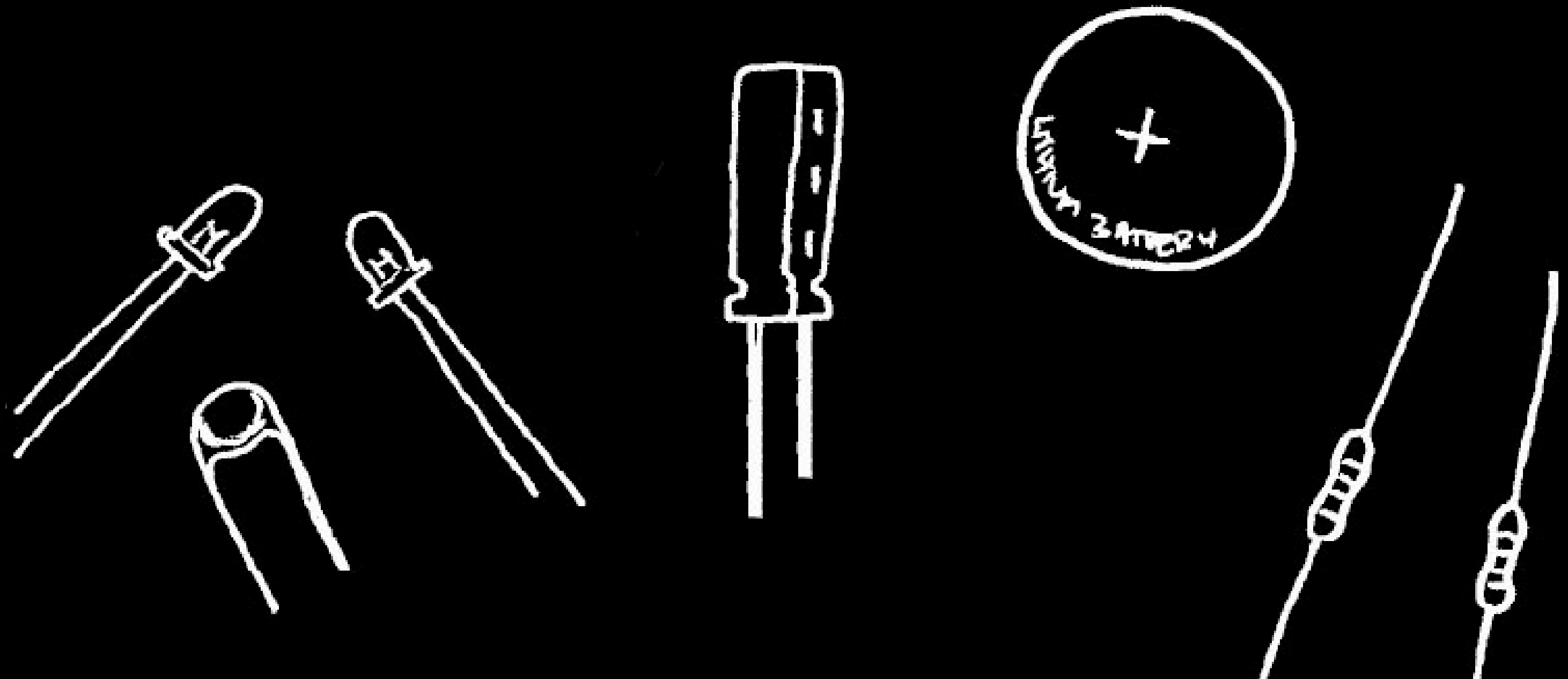

Everything You Need to Know About Electronics

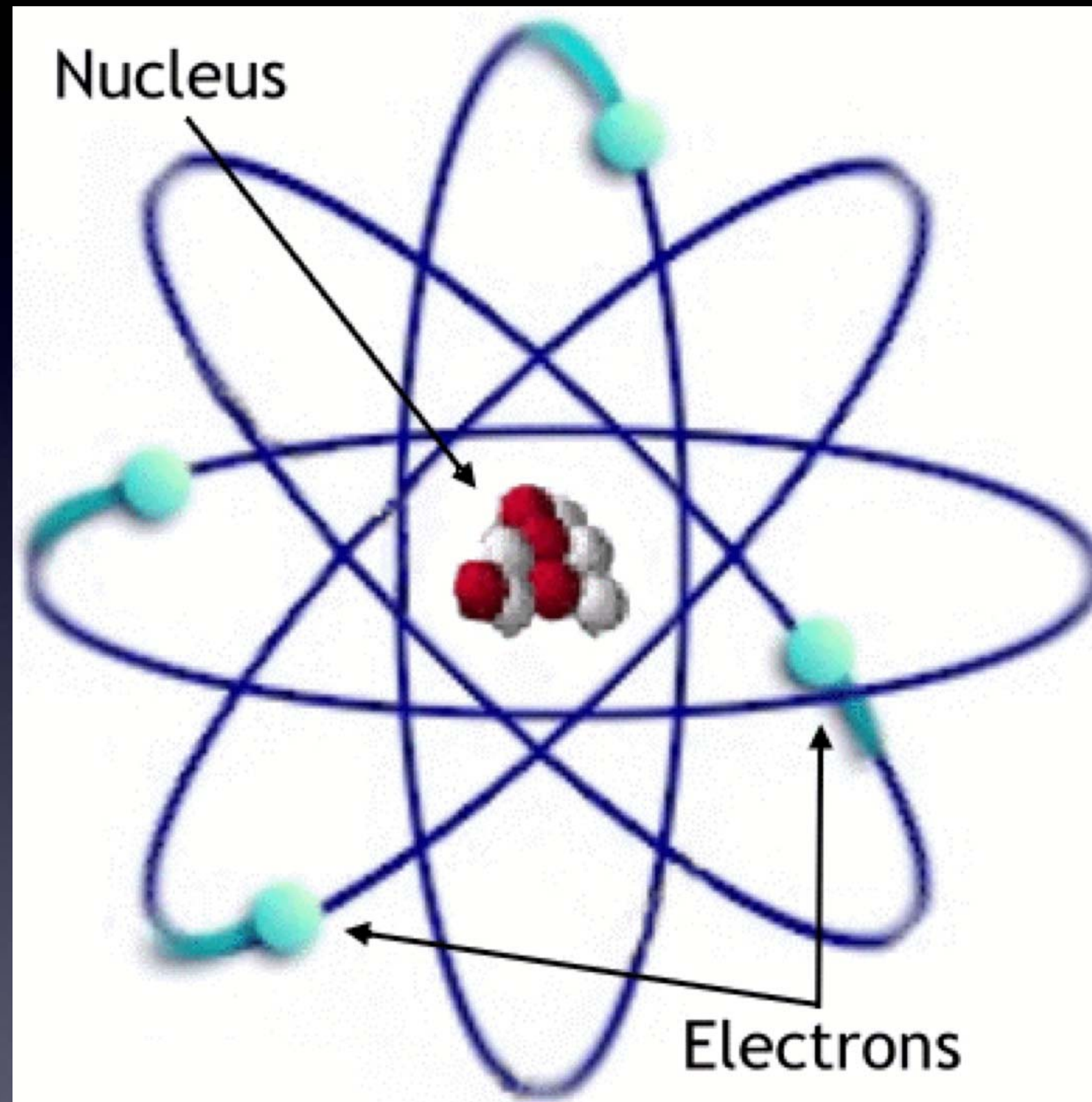

Electrons

Everything You Need to Know About Electronics

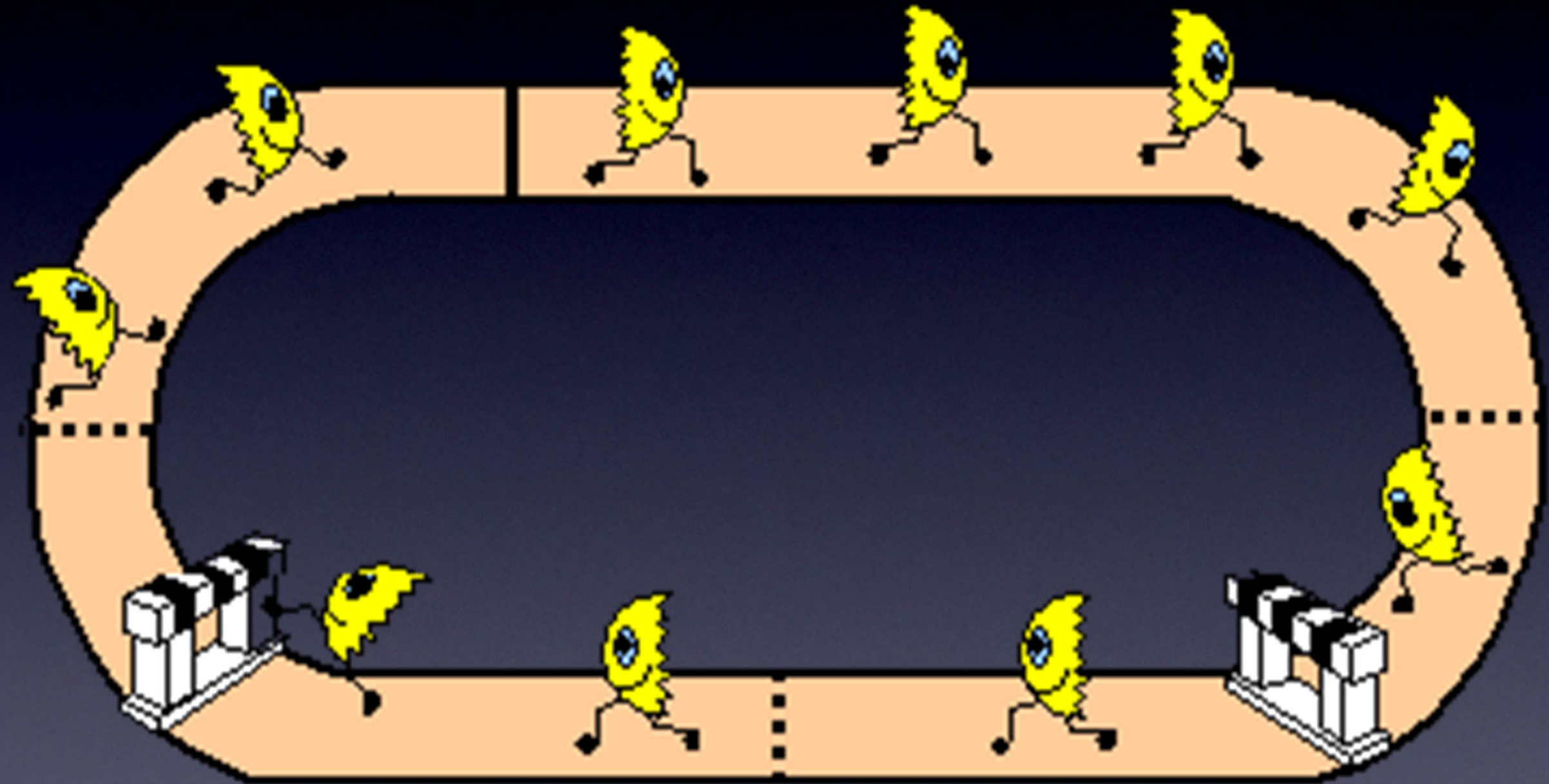

Circuit = Electrons going in complete circle = Magic!

Everything You Need to Know About Electronics

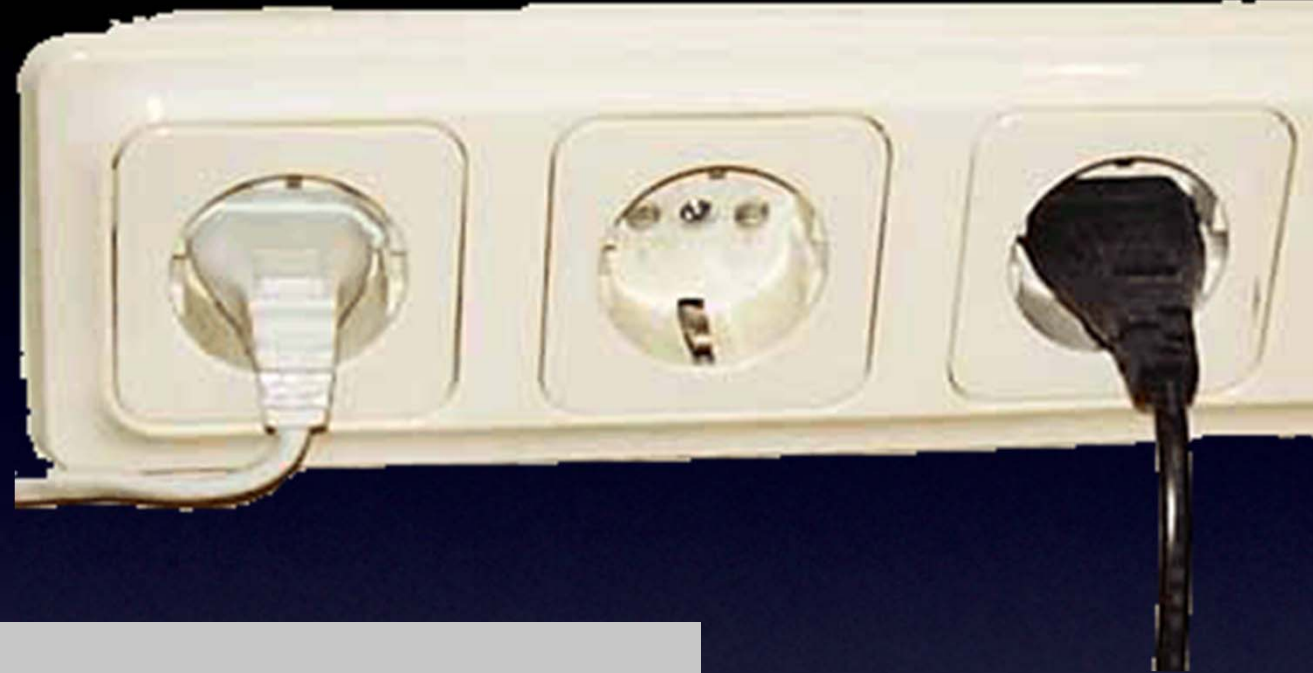

Power Supplies

Everything You Need to Know About Electronics



Volts / Voltage

Everything You Need to Know About Electronics

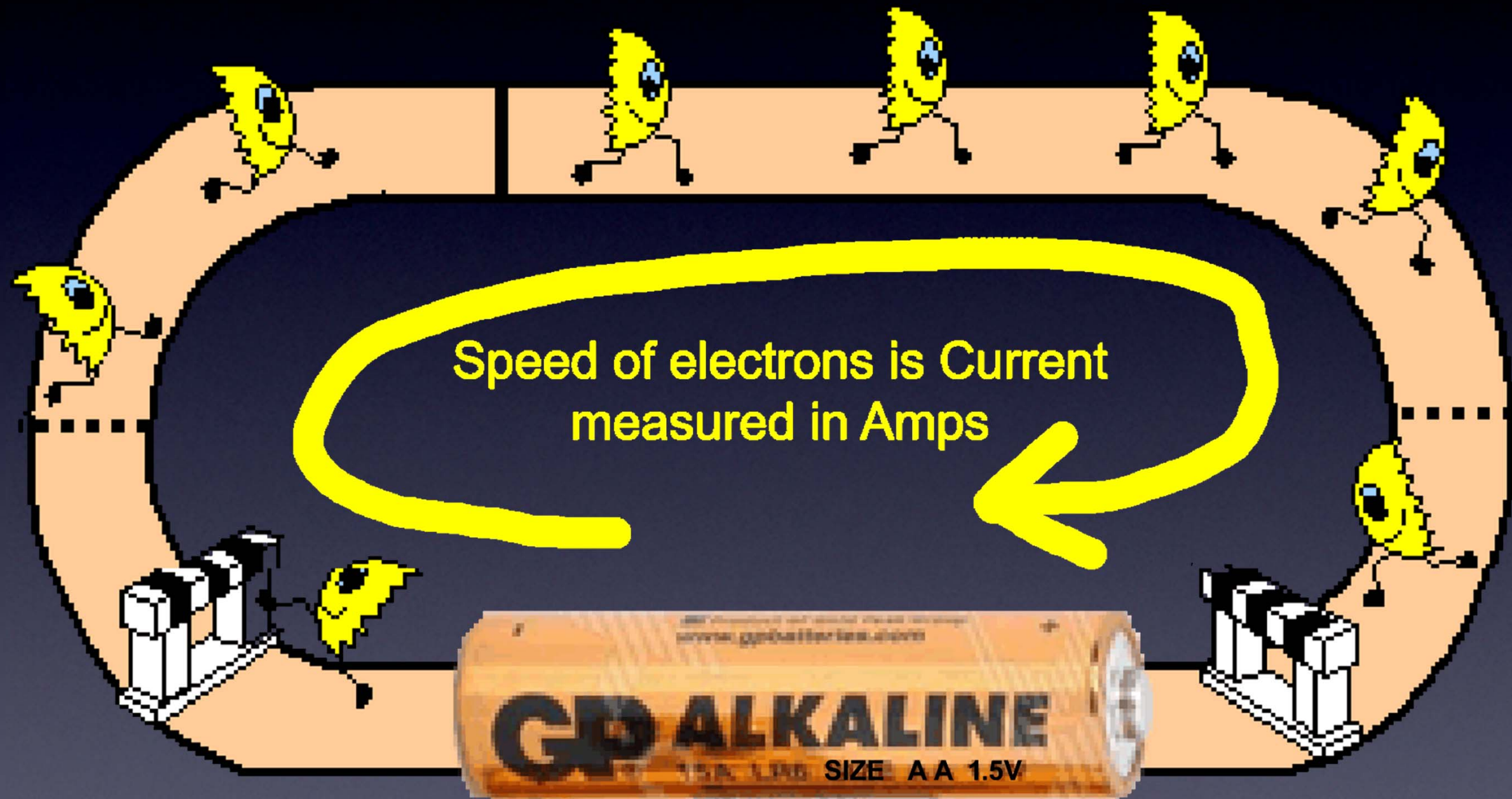

Electrons pushed with 1.5V.
So, they move!

Amps / Current

Everything You Need to Know About Electronics

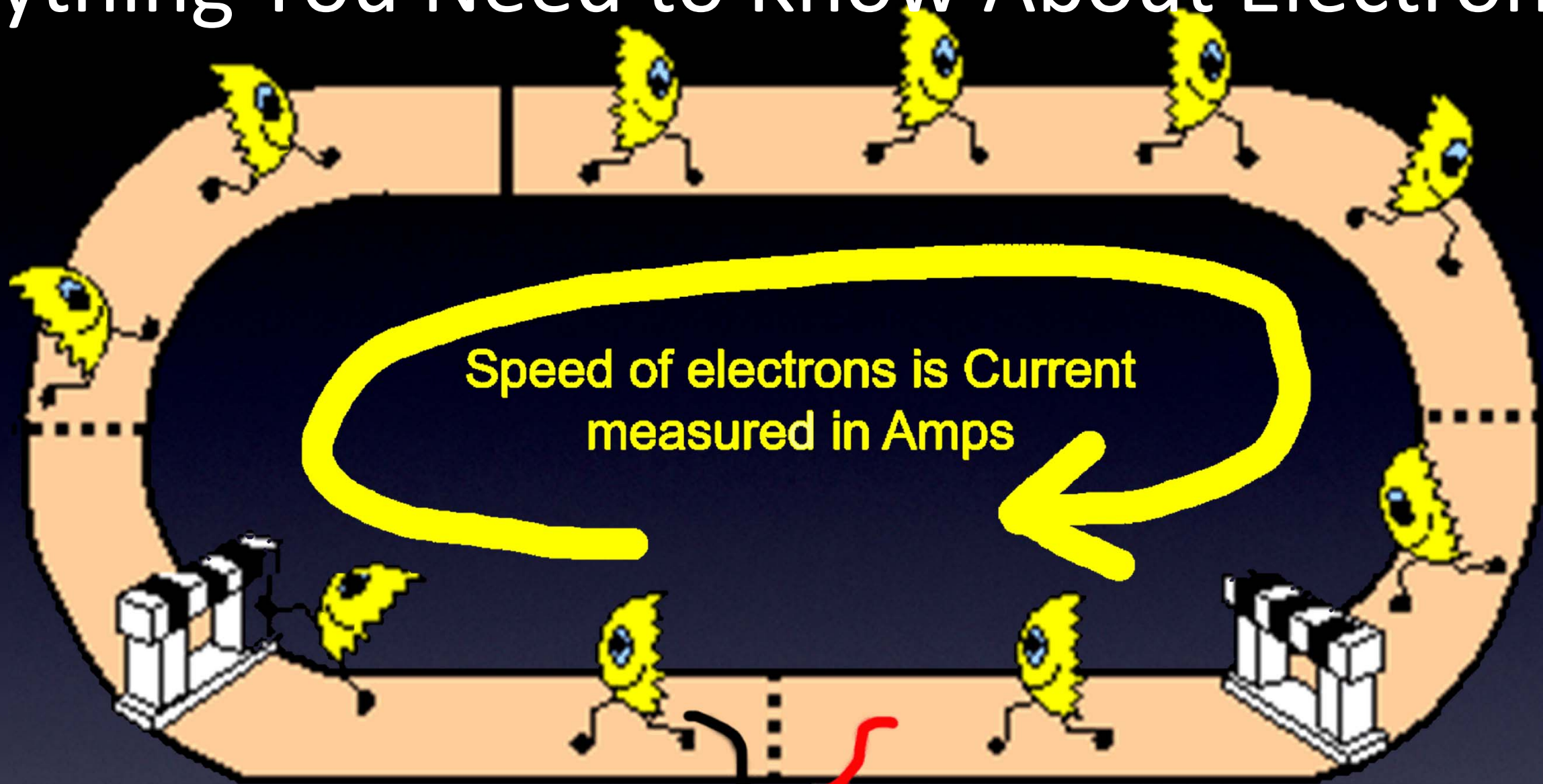

3 times more Volts
3 times more push
3 times faster electrons
3 times more current / Amps

Amps / Current

Everything You Need to Know About Electronics

Too much energy?

Lots of energy!

Amps / Current

Everything You Need to Know About Electronics

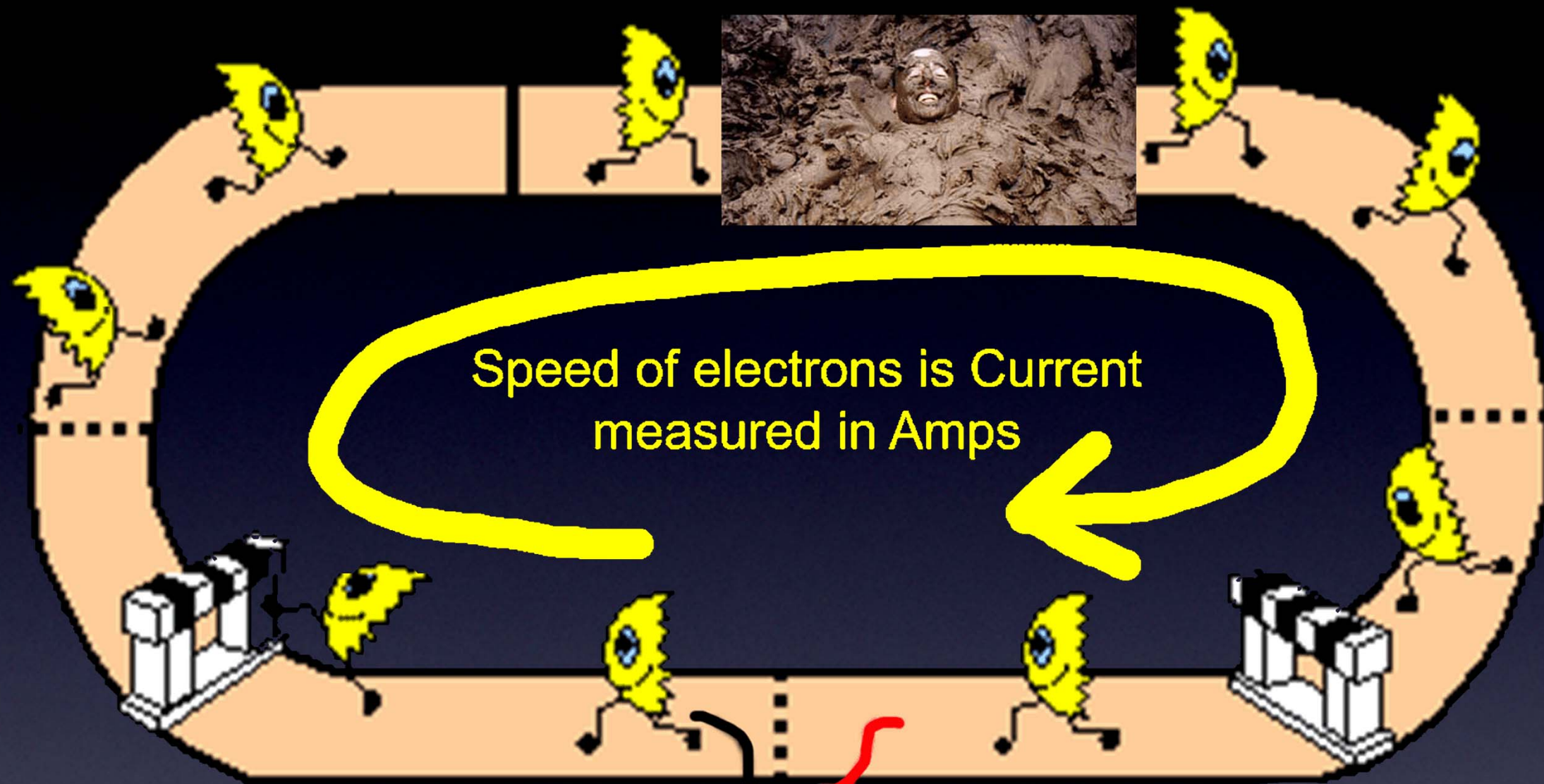

Resistance in the electrons' path slows them down, which means less current (less Amps).



Resistance / **Ohms**

Everything You Need to Know About Electronics

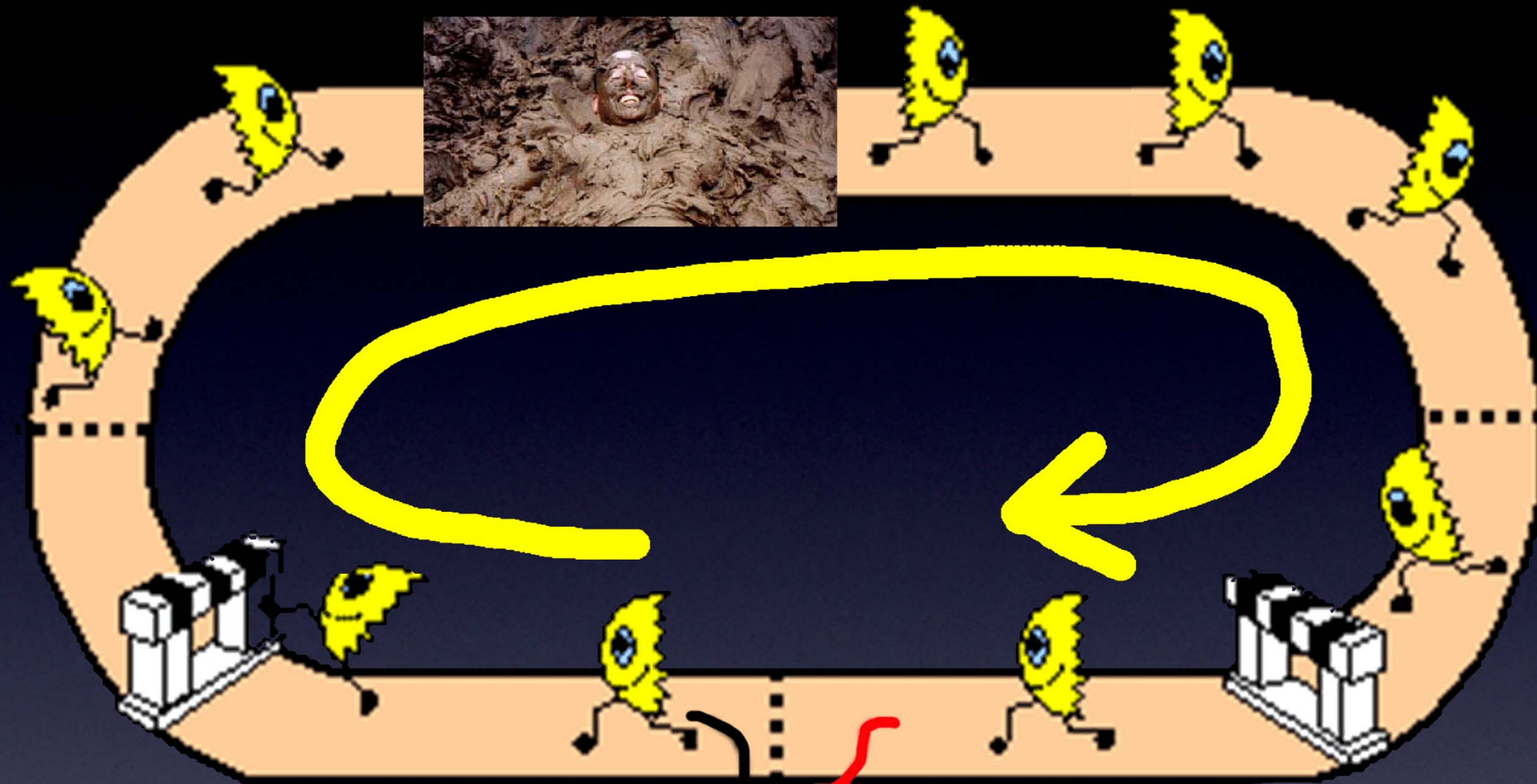

Resistance / Ohms

Same
Circuit!

Everything You Need to Know About Electronics

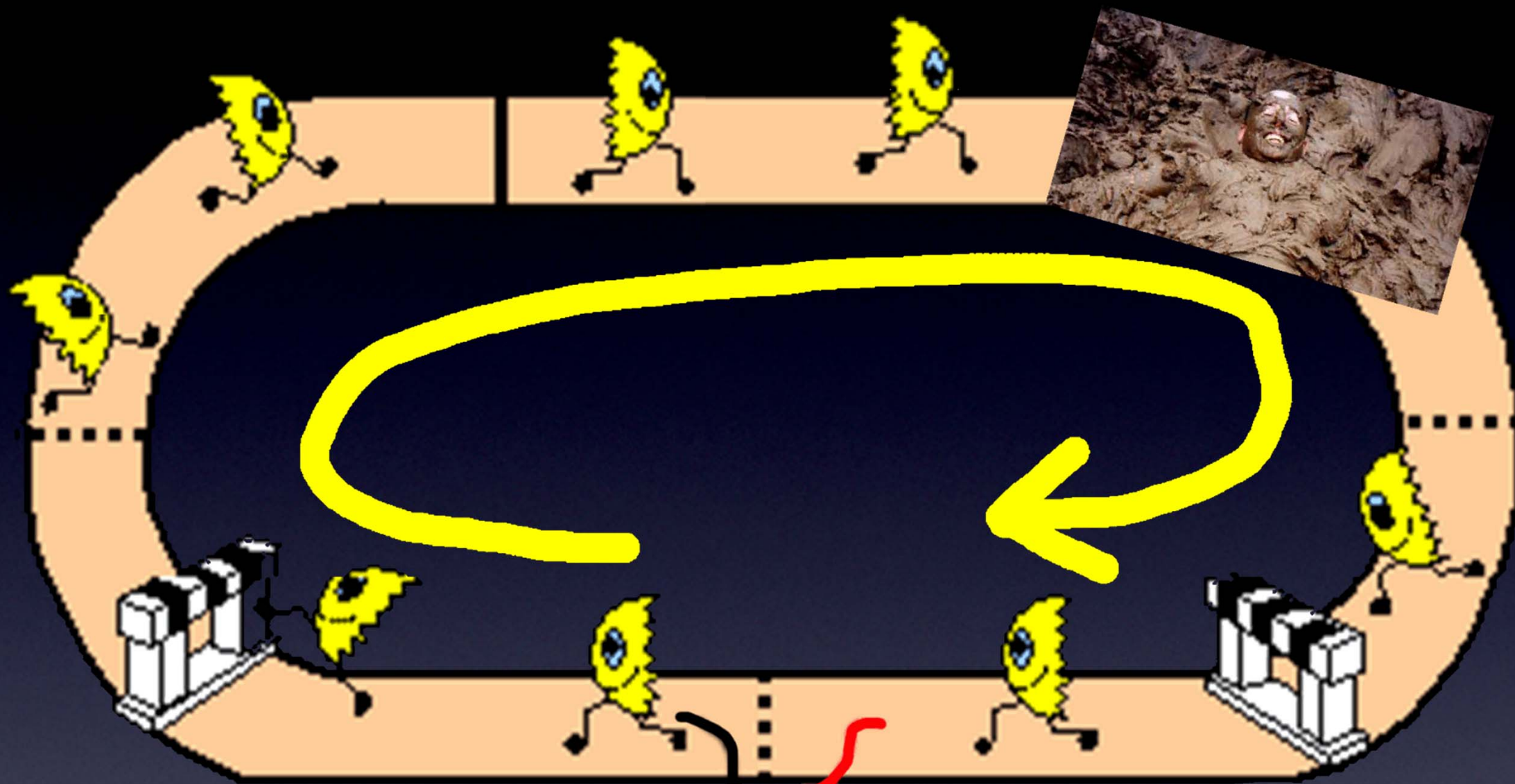

Same
Circuit!

Resistance / Ohms

Everything You Need to Know About Electronics

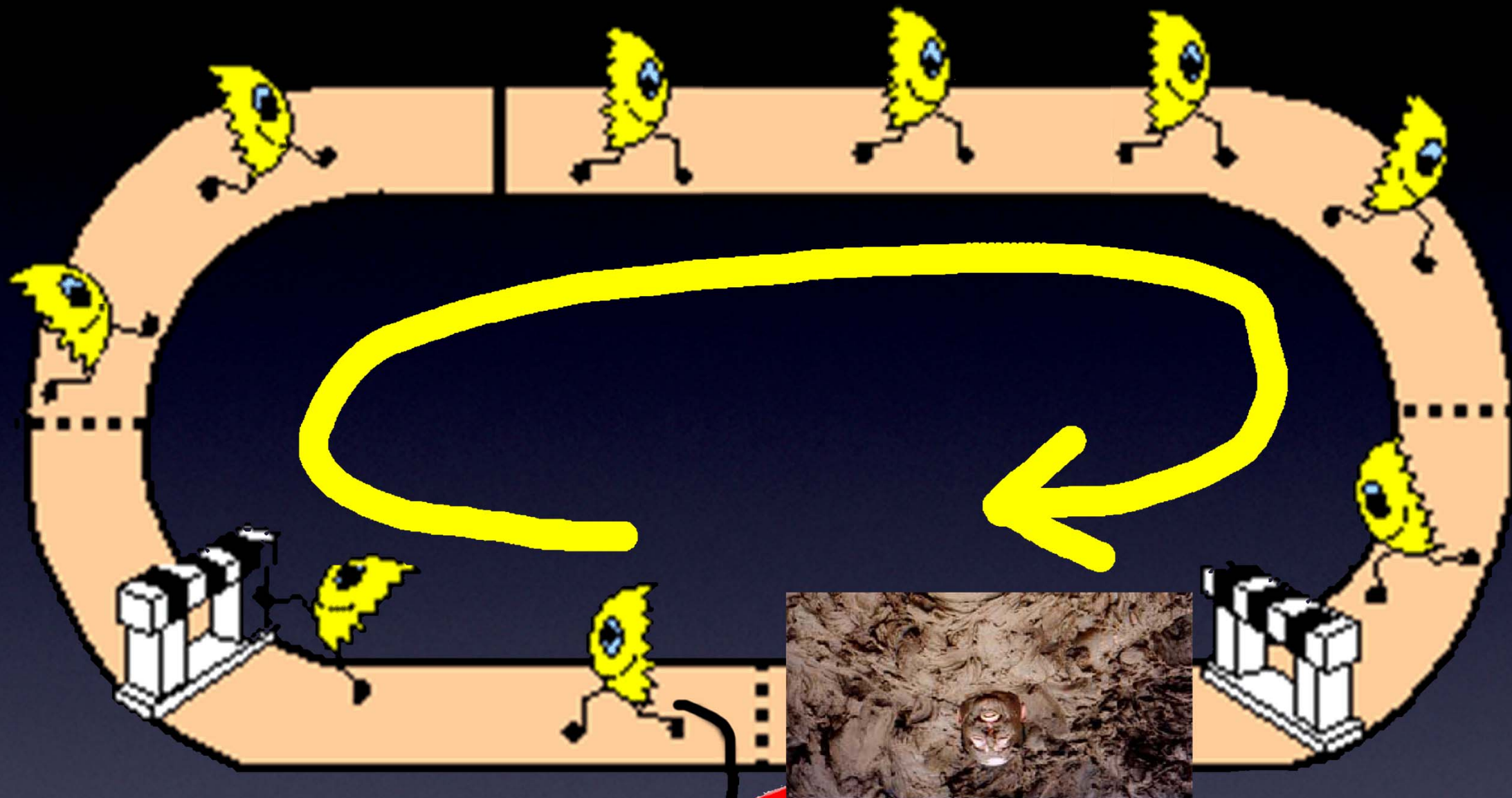

Resistance / Ohms

Same
Circuit!

Everything You Need to Know About Electronics

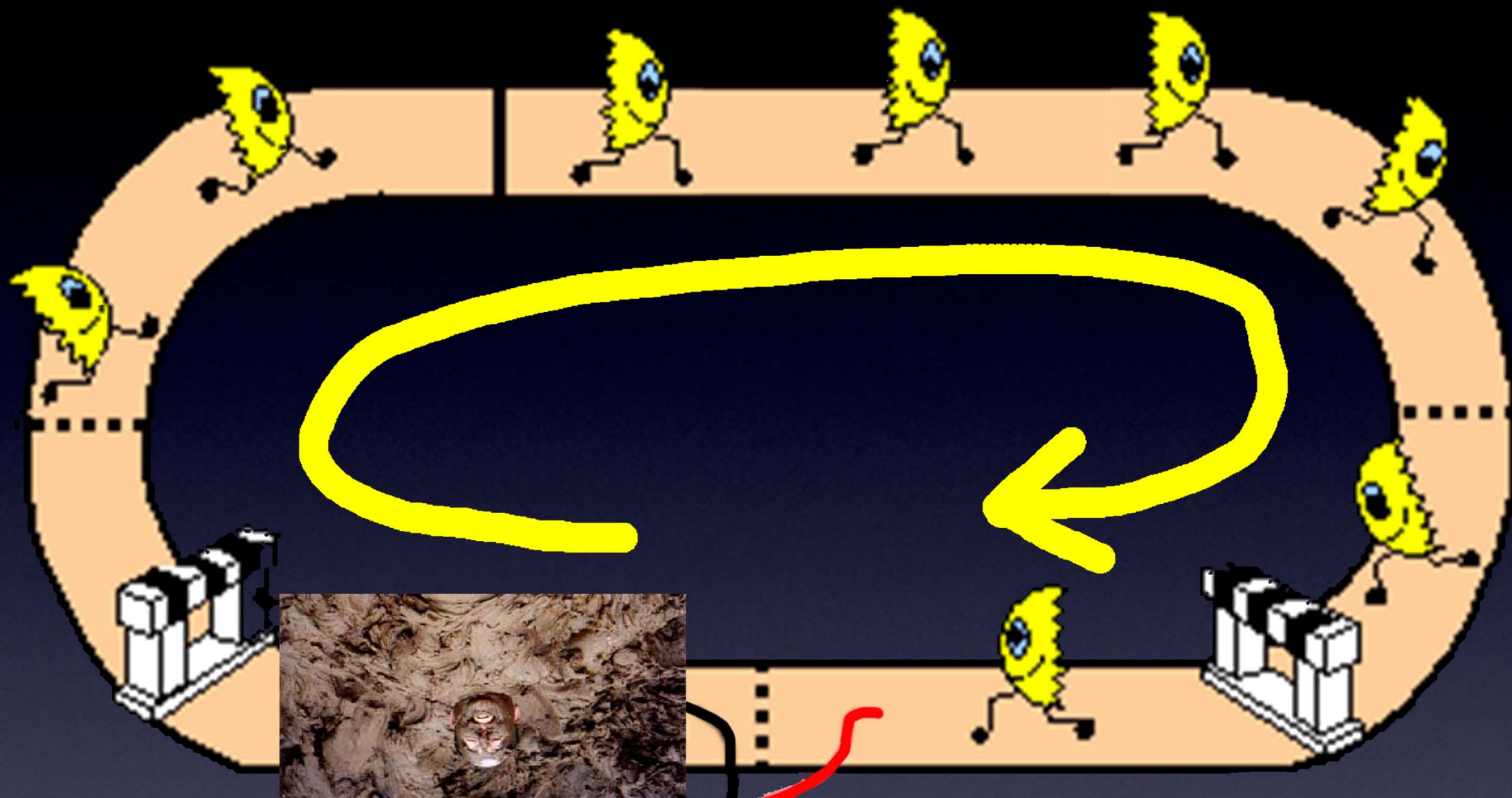

Same
Circuit!

Resistance / Ohms

Everything You Need to Know About Electronics

Ohm's Law

Volts -- *force* pushing electrons

Amps -- *speed* of electrons

Ohms -- *Resistance* to flow of electrons

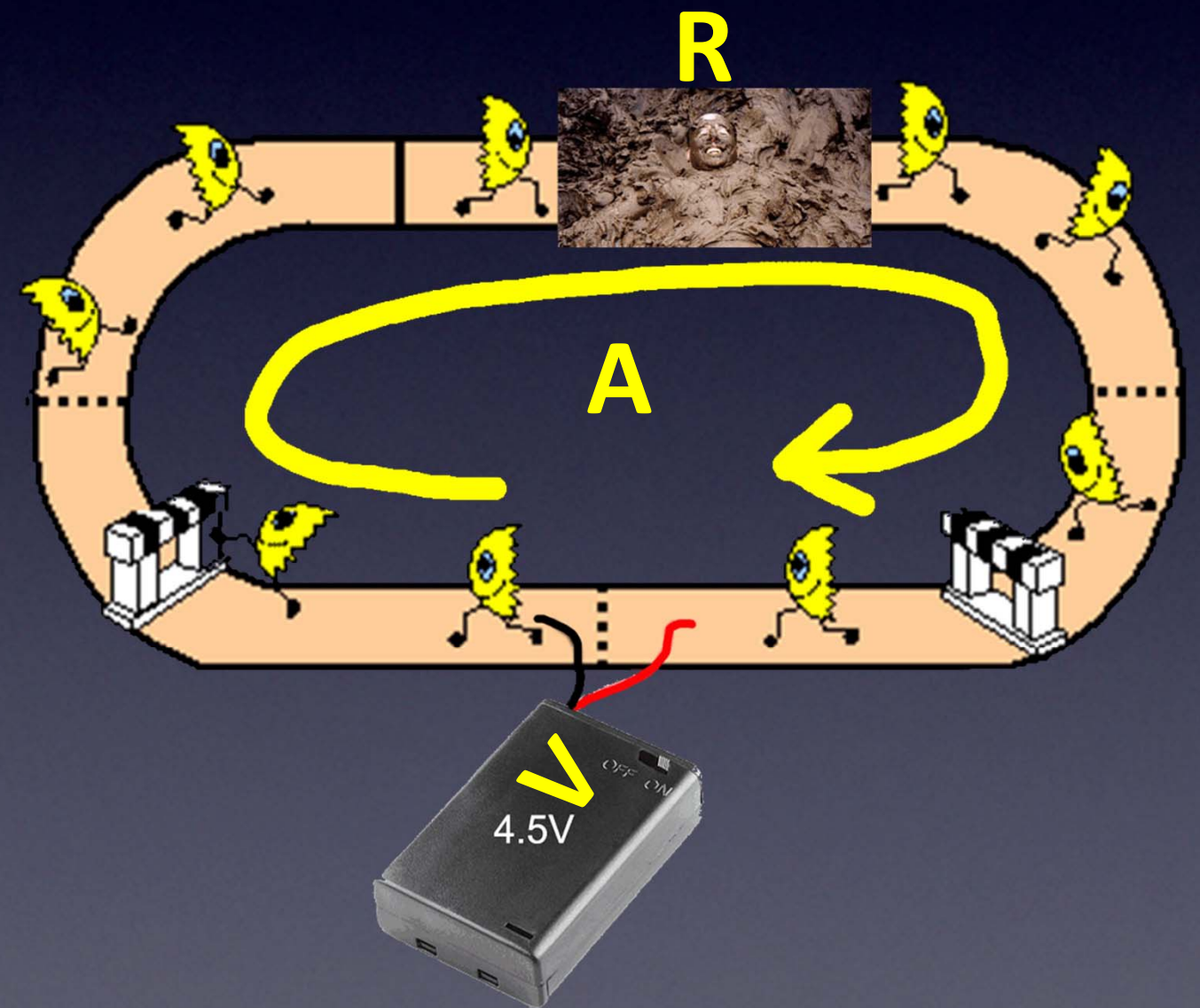

Everything You Need to Know About Electronics

Ohm's Law

Volts -- *force* pushing electrons

Amps -- *speed* of electrons

Ohms -- *Resistance* to flow of electrons

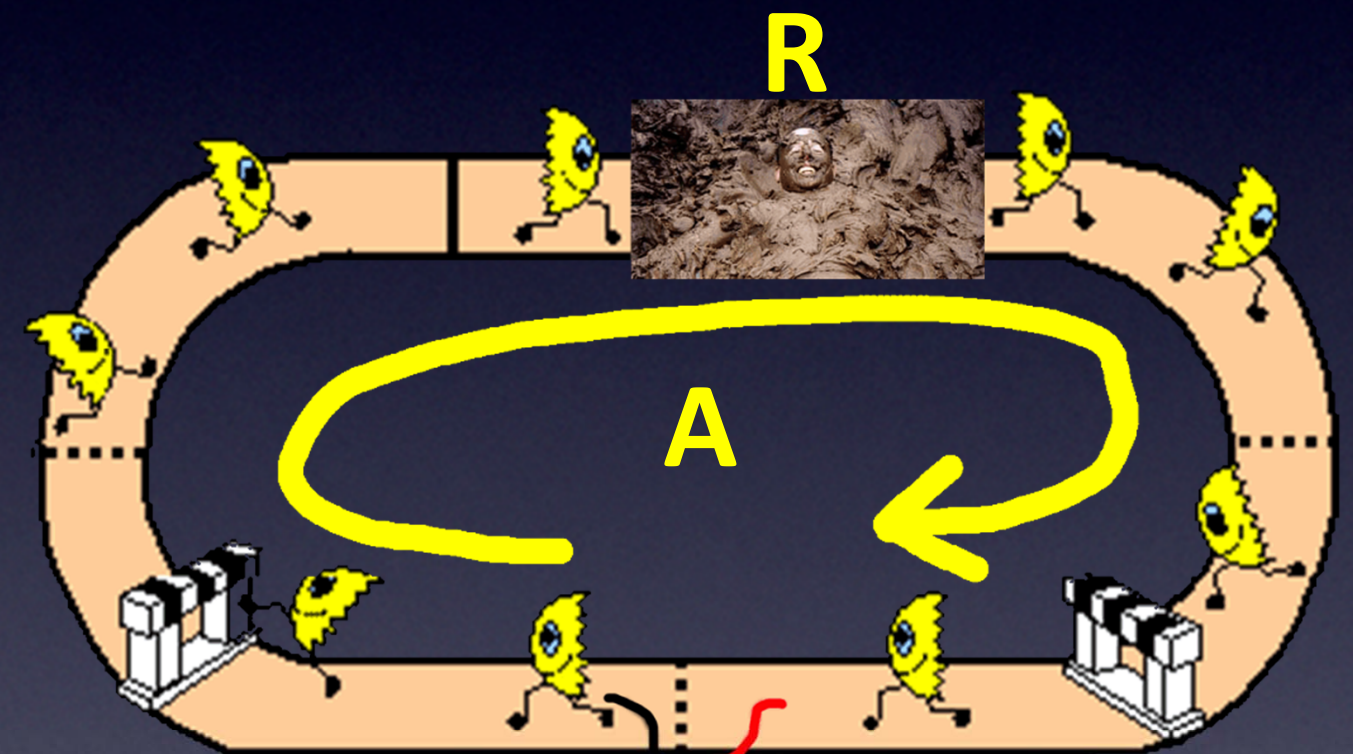

$$\mathbf{V} \text{olts} = \mathbf{A} \text{mps} \times \mathbf{R}$$

(Ohms)

Everything You Need to Know About Electronics

Ohm's Law

Volts -- *force* pushing electrons

Amps -- *speed* of electrons

Ohms -- *Resistance* to flow of electrons

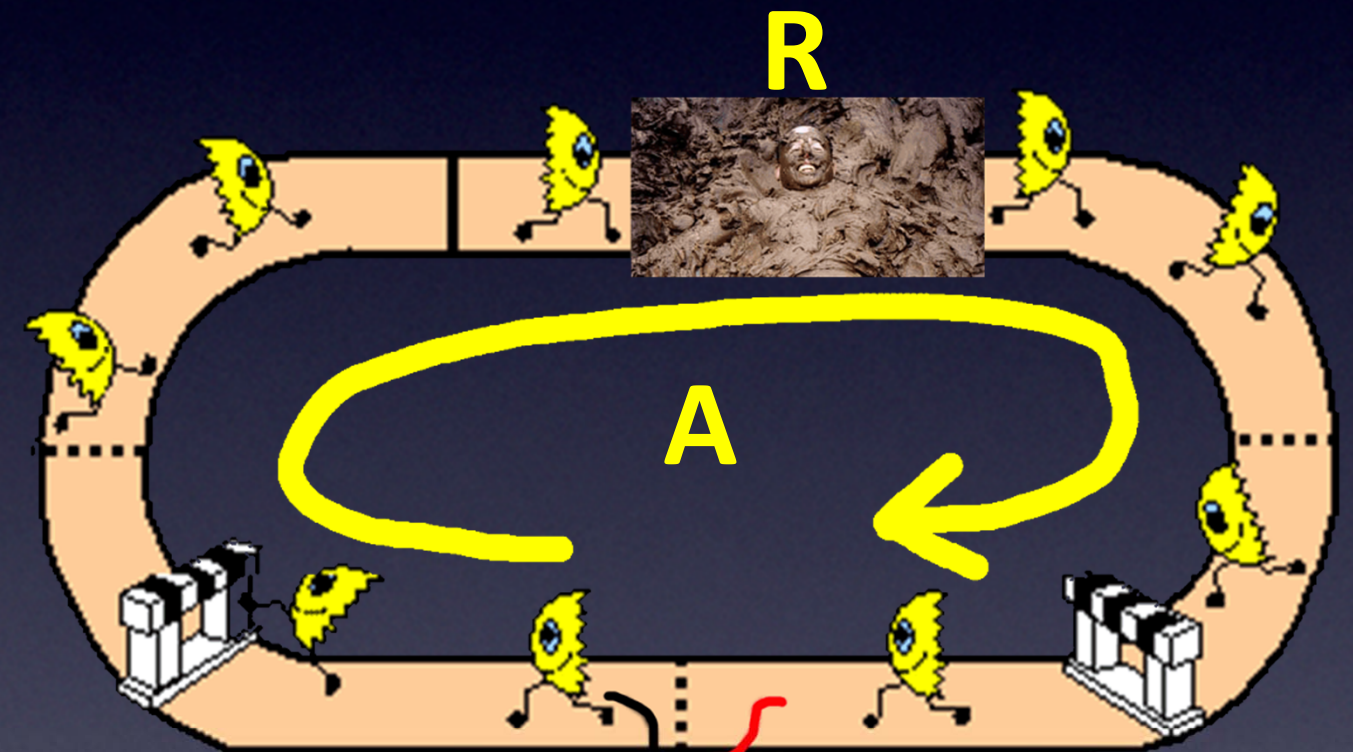

$$\text{Volts} = \text{Amps} \times R$$

Also commonly written: $E = I \times R$

(Ohms)

Everything You Need to Know About Electronics

The symbol for
Resistance:

Ω

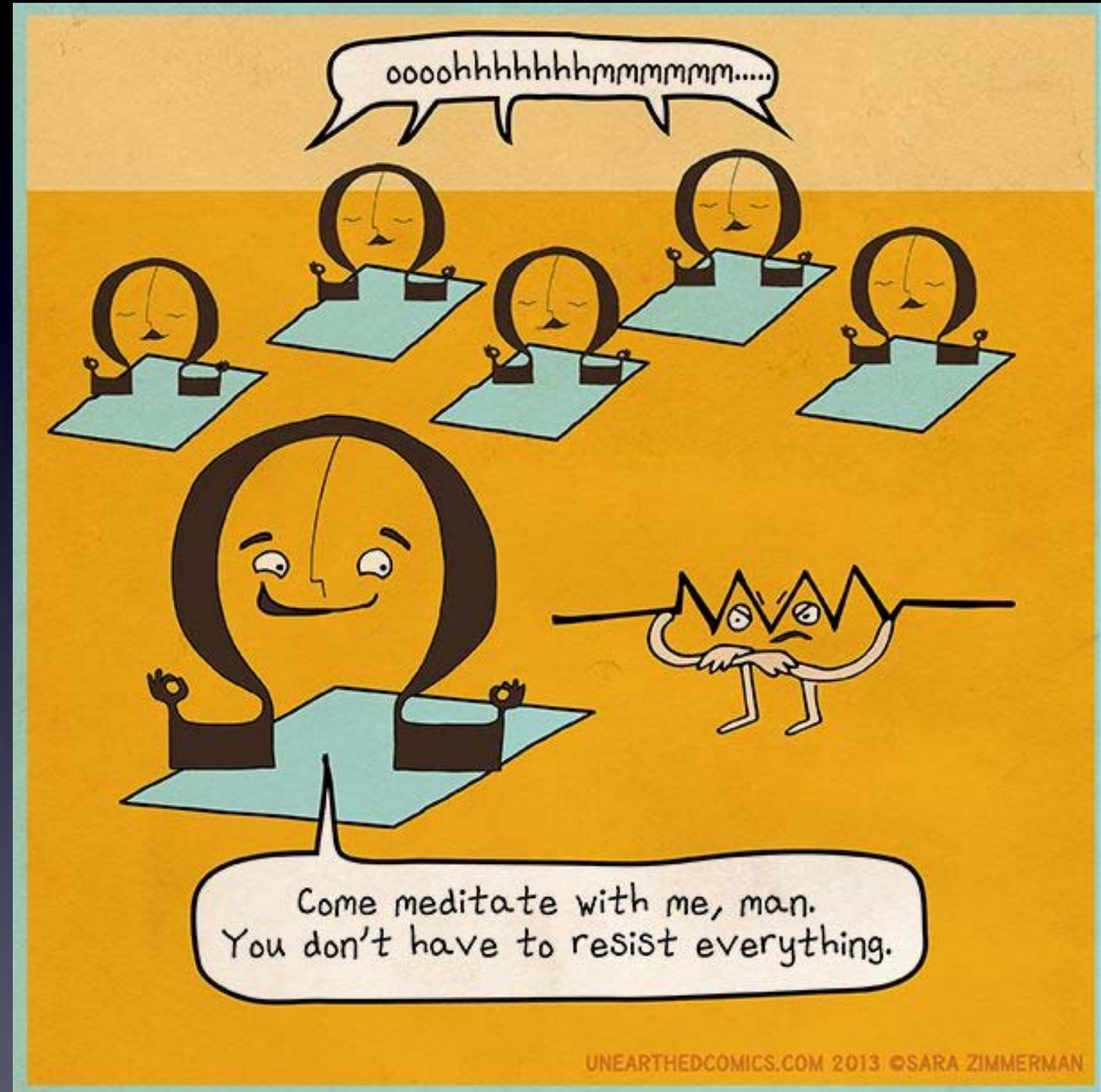

Resistors / Ohms

Everything You Need to Know About Electronics

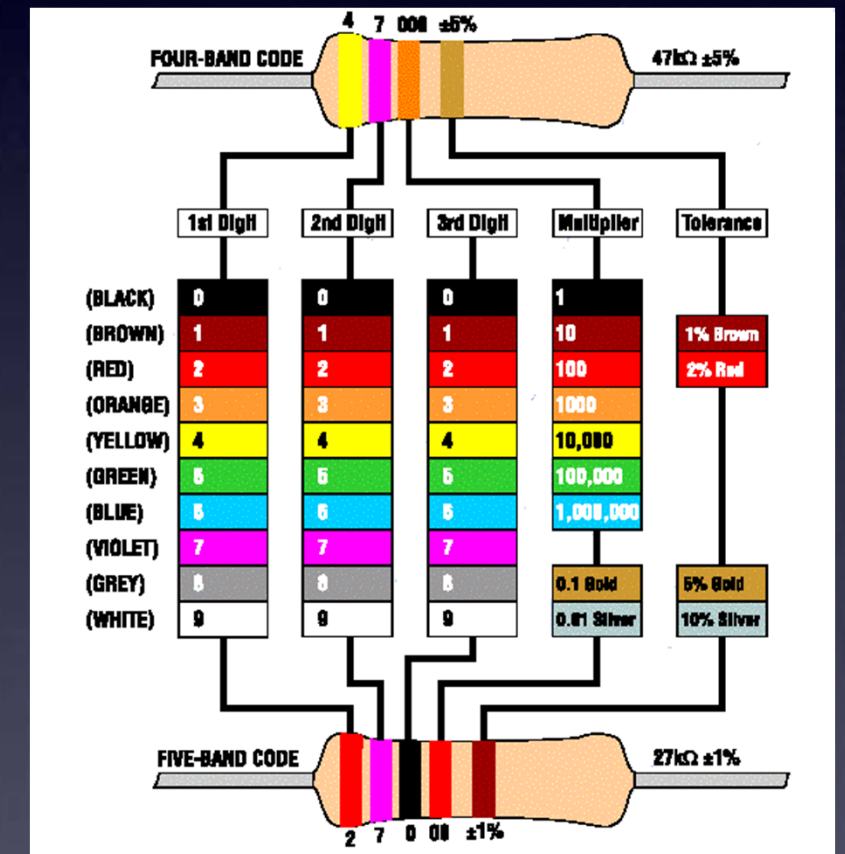
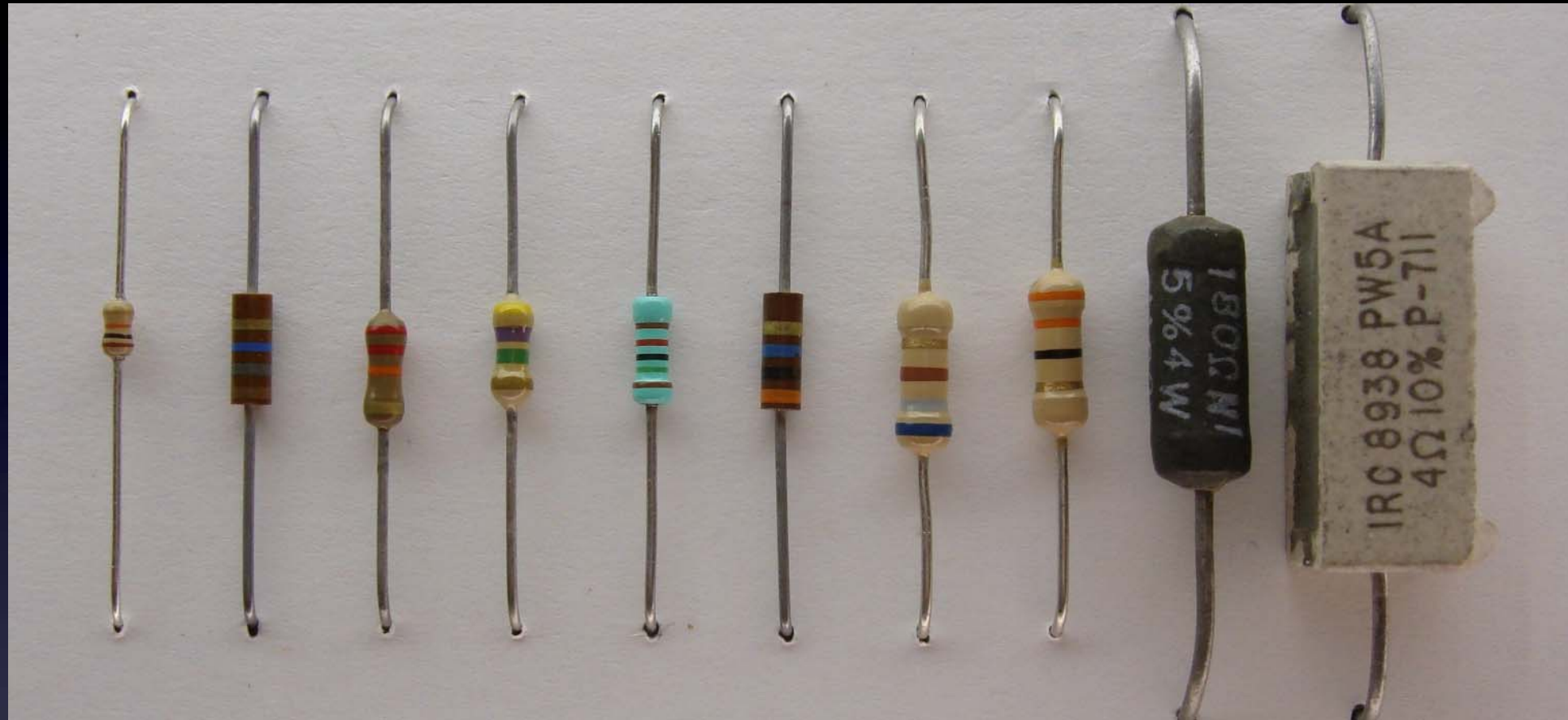

Resistors / Ohms

Everything You Need to Know About Electronics



What happens?

polarity

Power Supply – it matters how you connect it!

Everything You Need to Know About Electronics

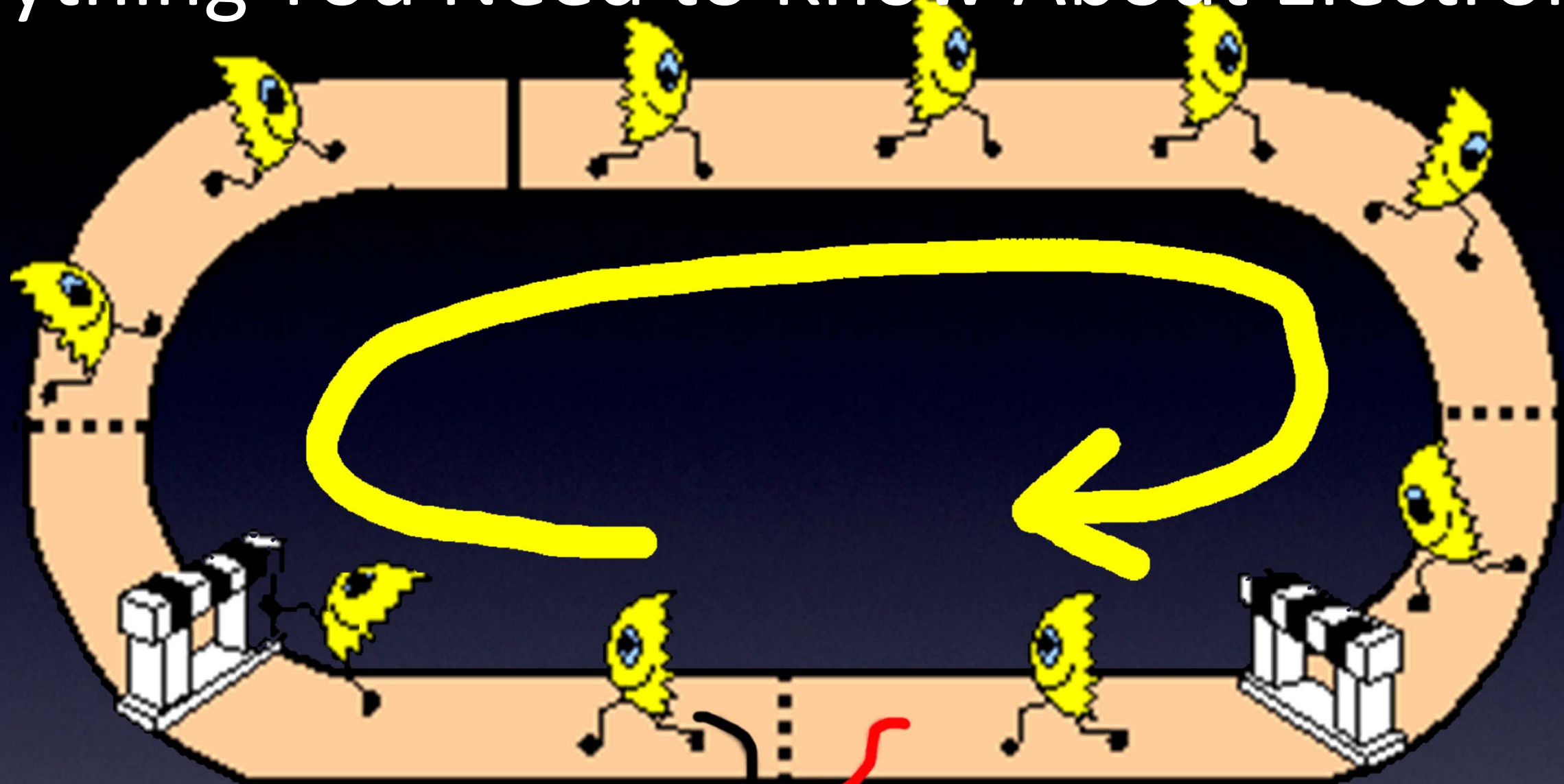

Black Wire = “-”

Red Wire = “+”



Power Supply – it matters how you connect it!

Everything You Need to Know About Electronics



Red wire:
Power,
Plus, Positive,
4.5V,
Vcc

Black wire:
Minus, Negative,
0V,
Ground (GND)

Power Supply – it matters how you connect it!

Everything You Need to Know About Electronics

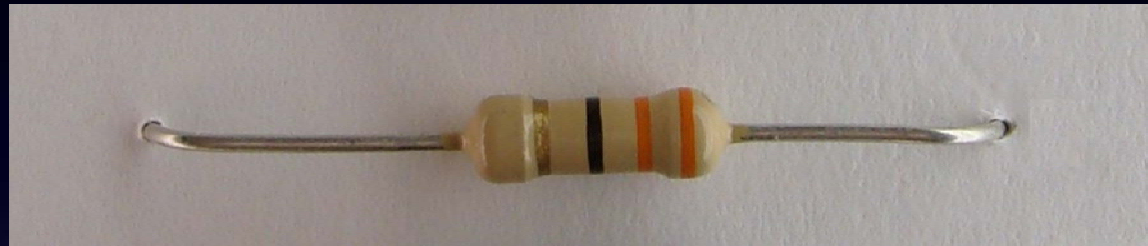

or



or



(electrons slowed down the same either way)

Resistors – it doesn't matter which way

Everything You Need to Know About Electronics

Minus / Negative side

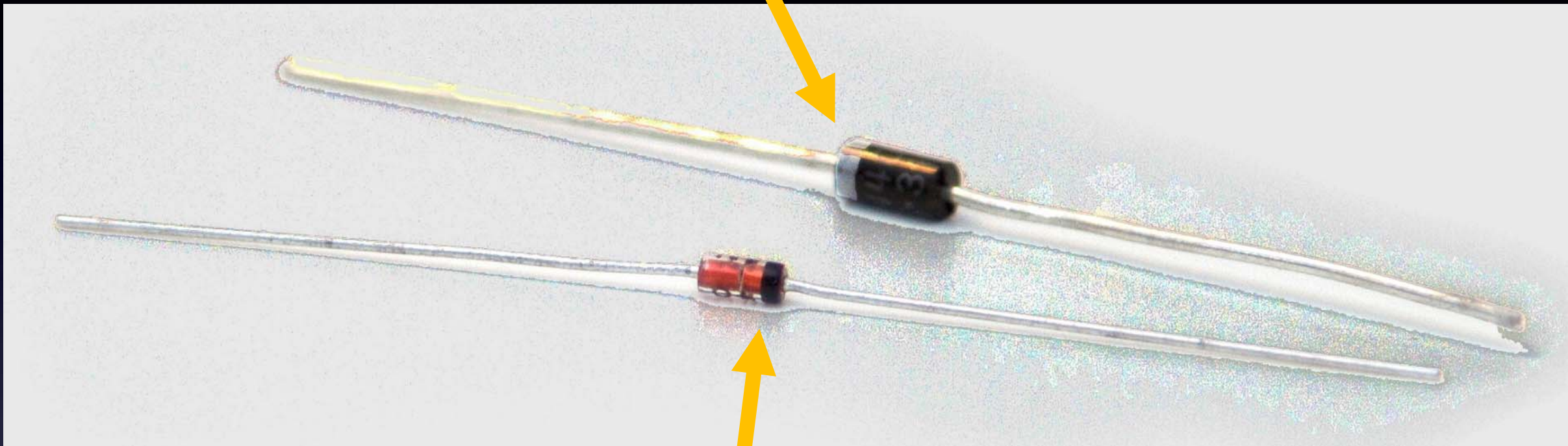

Minus / Negative side

Diodes – One-Way valve for electrons

Diodes – it matters which way!

Everything You Need to Know About Electronics



Short wire is Minus / Negative

Special kind of Diode – it Emits Light!

LED – it matters which way!

Everything You Need to Know About Electronics



Lots of different colored LEDs! (including IR)

LED

Everything You Need to Know About Electronics

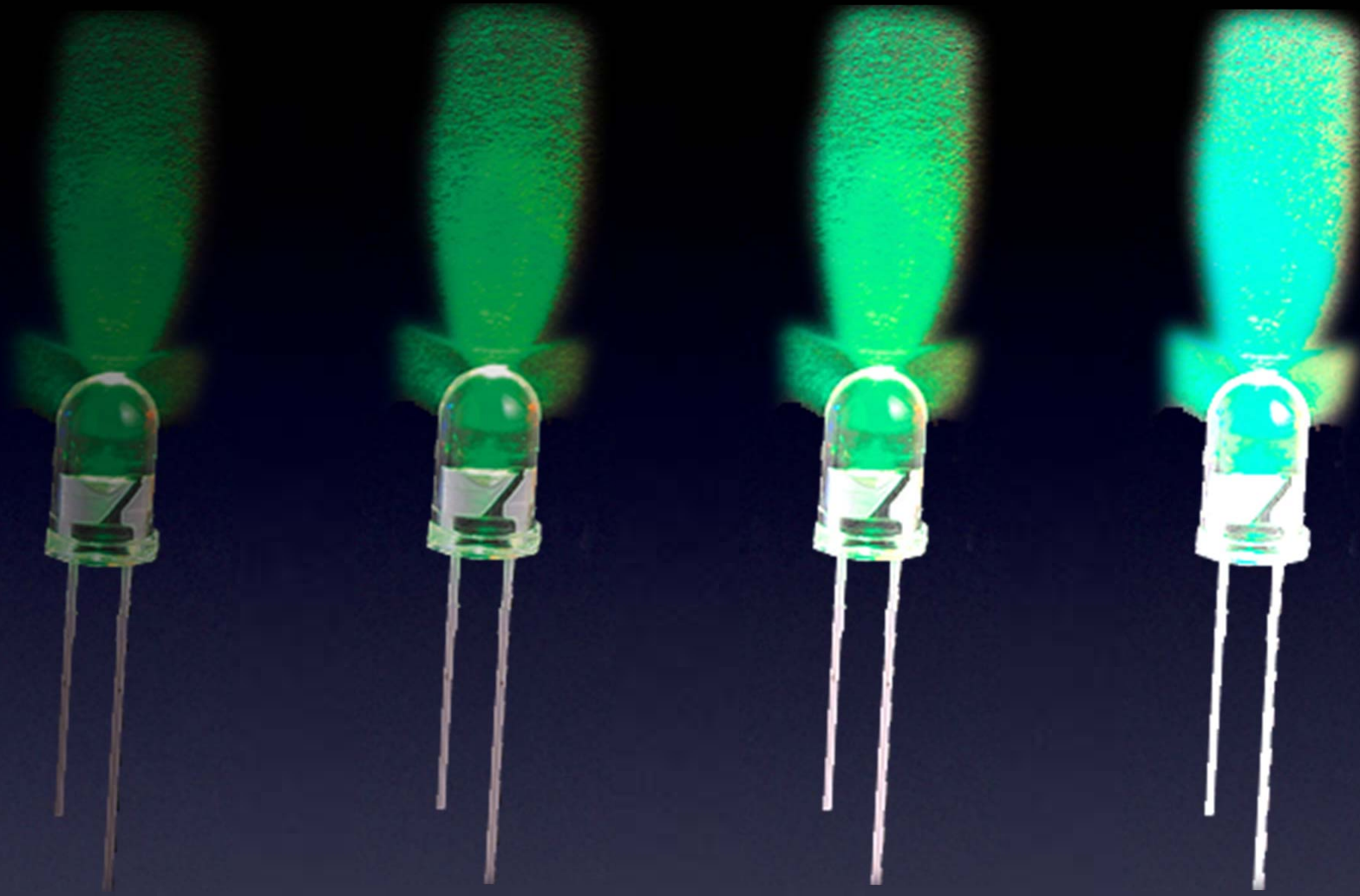

More current → More brightness! (until...)

LED

Everything You Need to Know About Electronics



More current → More brightness! (until...)

LED

Everything You Need to Know About Electronics

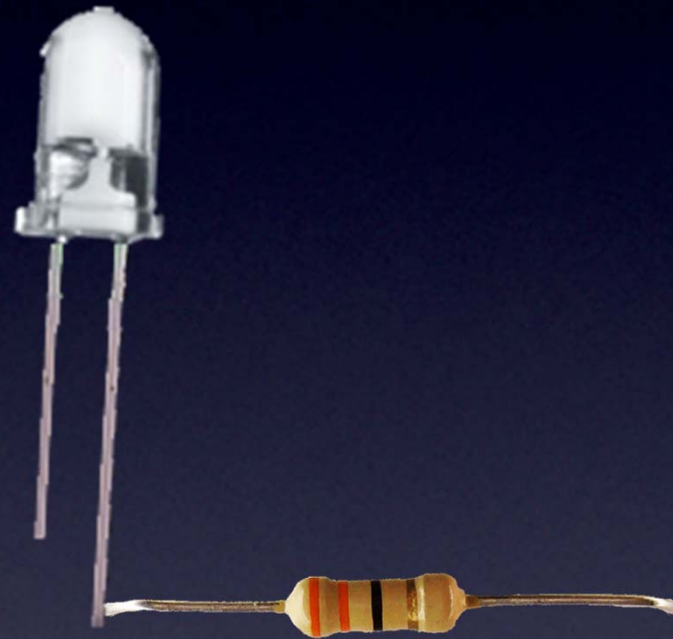

*(with a resistor
so no magic smoke goes away)*

This is why we put a resistor in line with an LED

LED

Everything You Need to Know About Electronics

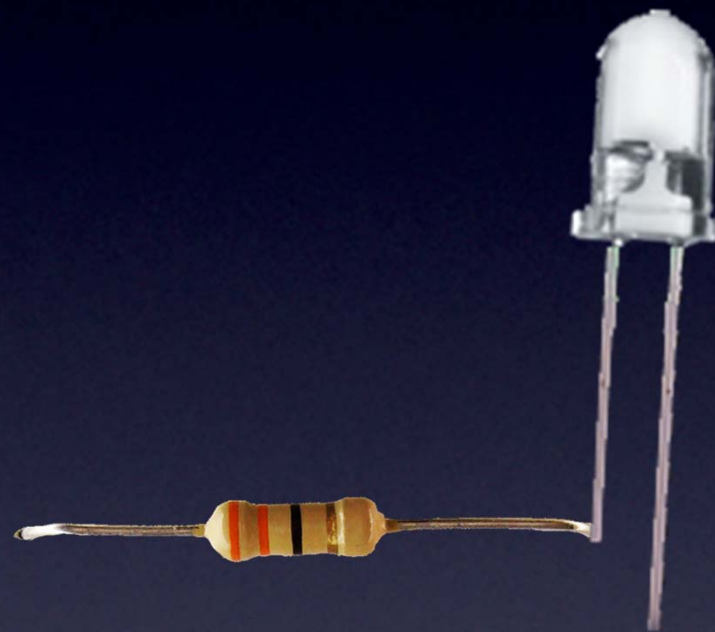

(the resistor can go on either side)

This is why we put a resistor in line with an LED

LED

Everything You Need to Know About Electronics



Series = in line

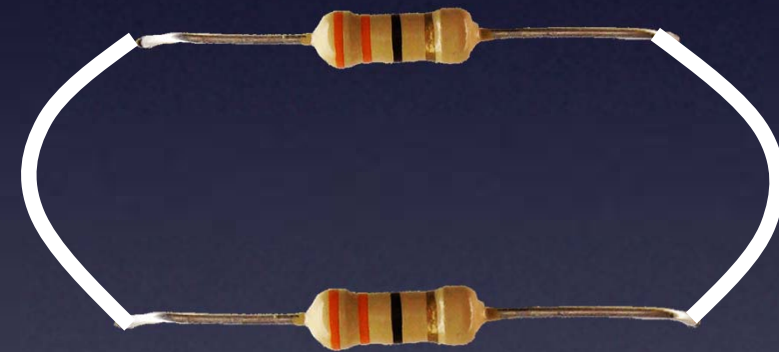

Parallel = across

Everything You Need to Know About Electronics

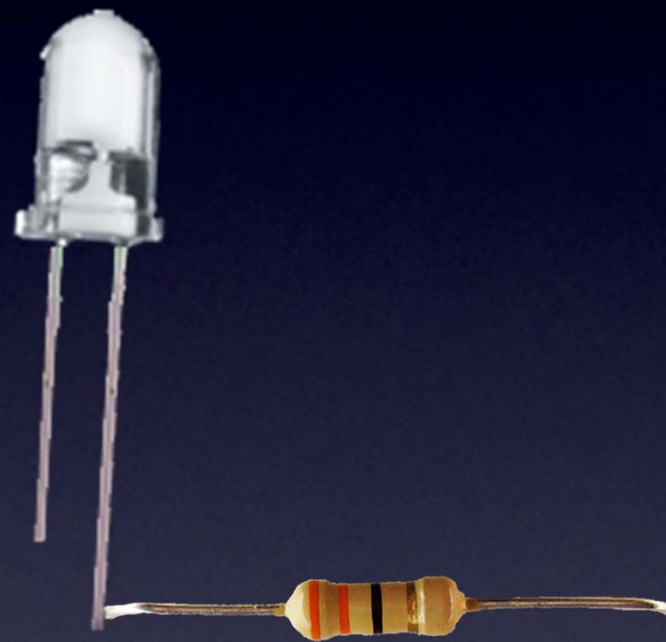

Let's make this light up!

LED

Everything You Need to Know About Electronics

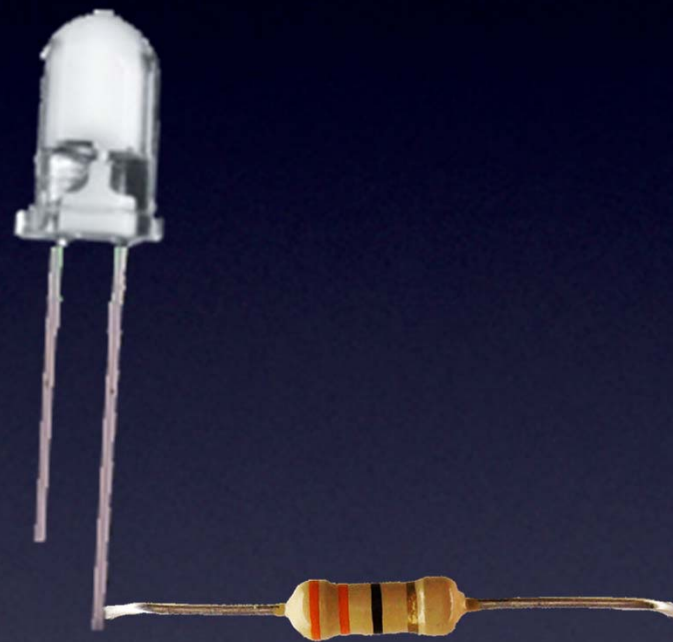
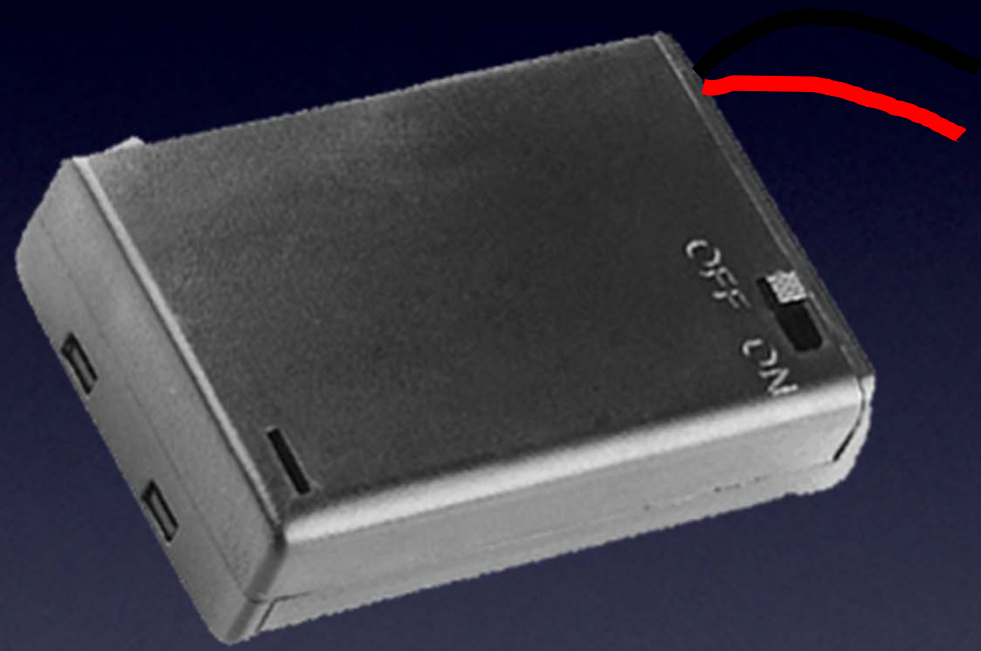

(add a power supply)

Let's make this light up!

LED

Everything You Need to Know About Electronics

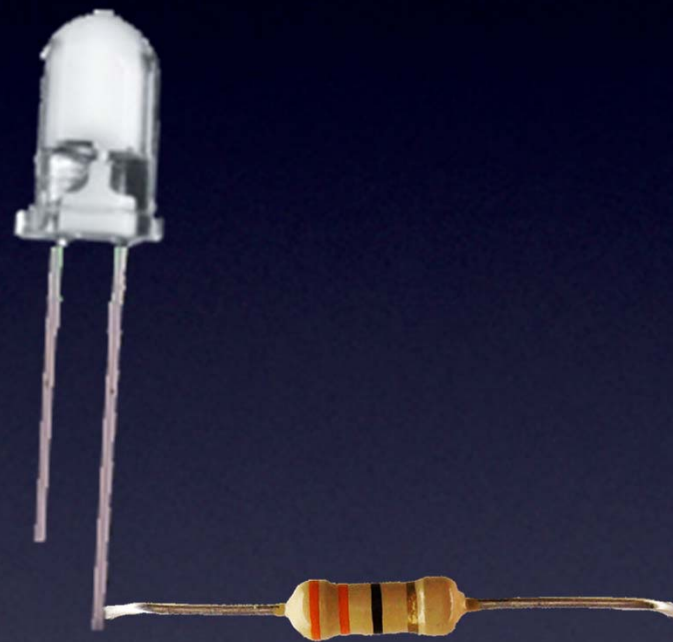
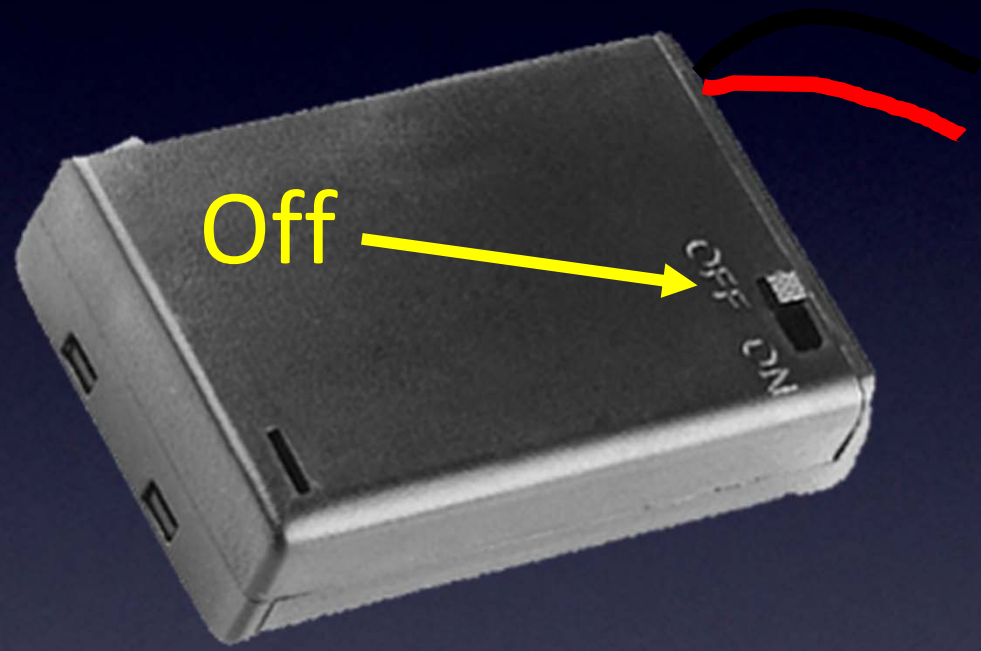

Let's make this light up!

LED

Everything You Need to Know About Electronics

Black wire: “-” (ground)



Red wire: “+” power)

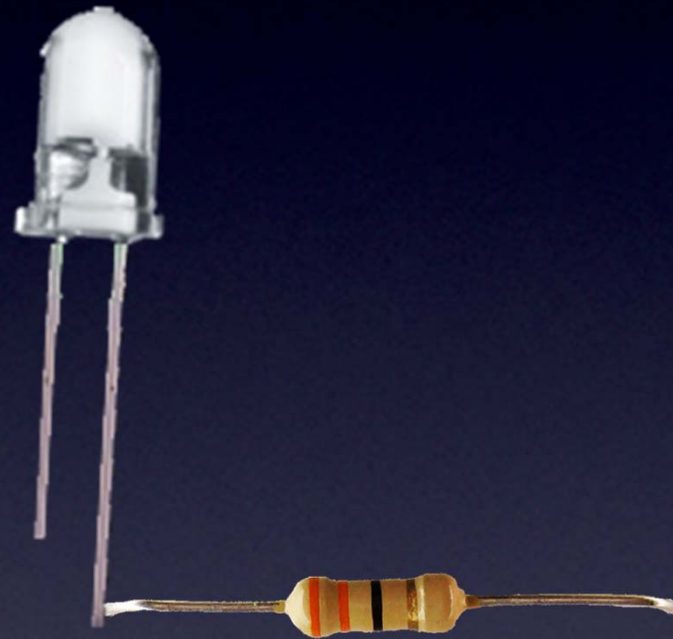

Let's make this light up!

LED

Everything You Need to Know About Electronics

short lead: “-”

Black wire: “-” (ground)

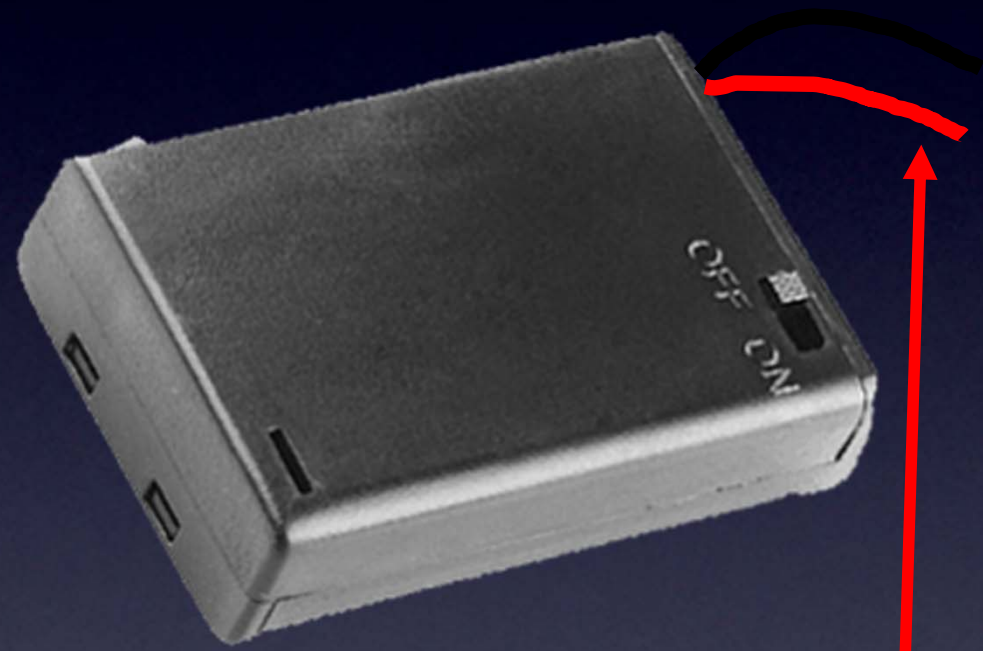

Red wire: “+” power)

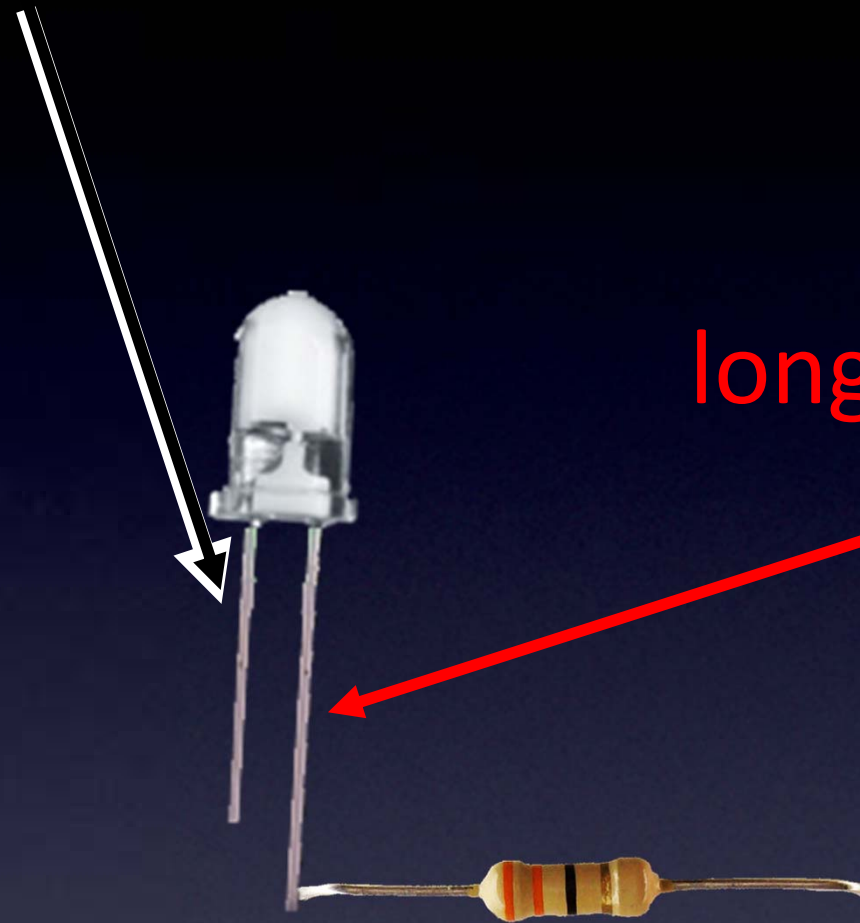

long lead: “+”

Let's make this light up!

LED

Everything You Need to Know About Electronics

short lead: “-”

Black wire: “-” (ground)

long lead: “+”

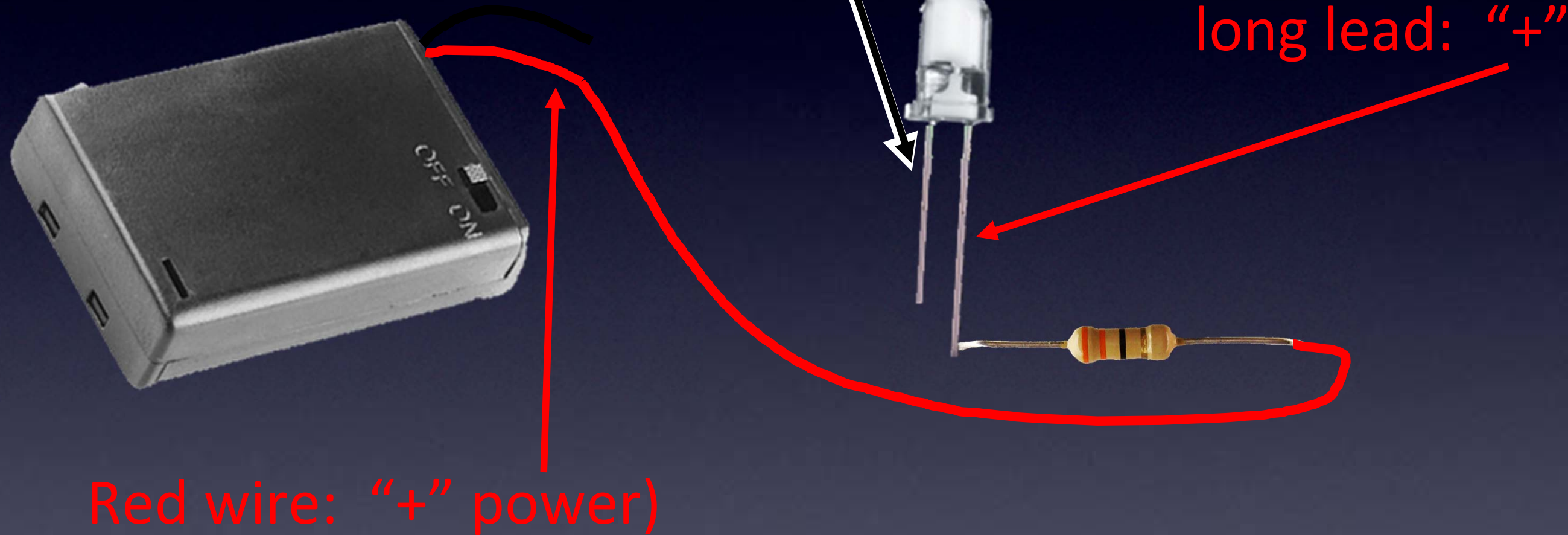

Let's make this light up!

LED

Everything You Need to Know About Electronics

short lead: “-”

Black wire: “-” (ground)

long lead: “+”



Red wire: “+” power)

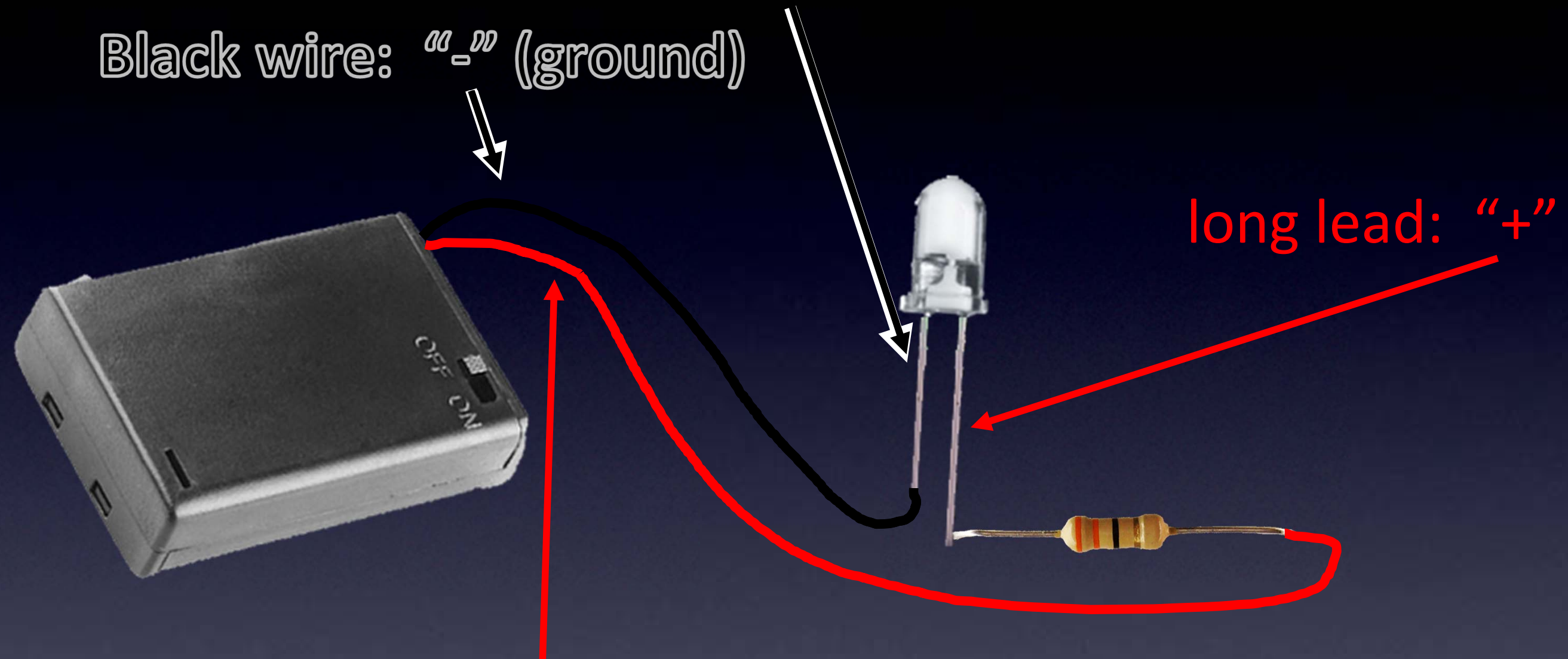

Let's make this light up!

LED

Everything You Need to Know About Electronics

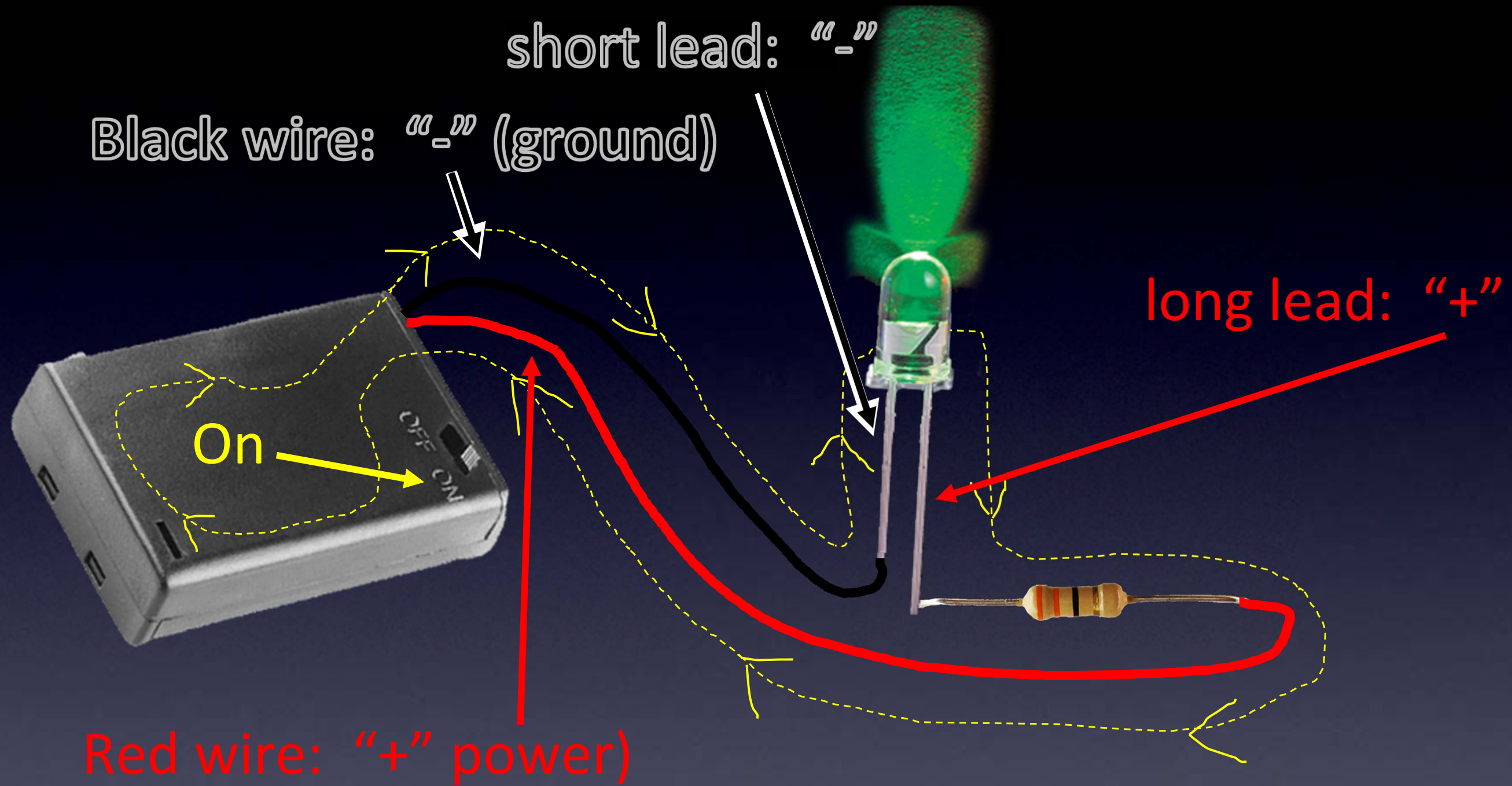

It lights!

LED

Everything You Need to Know About Electronics

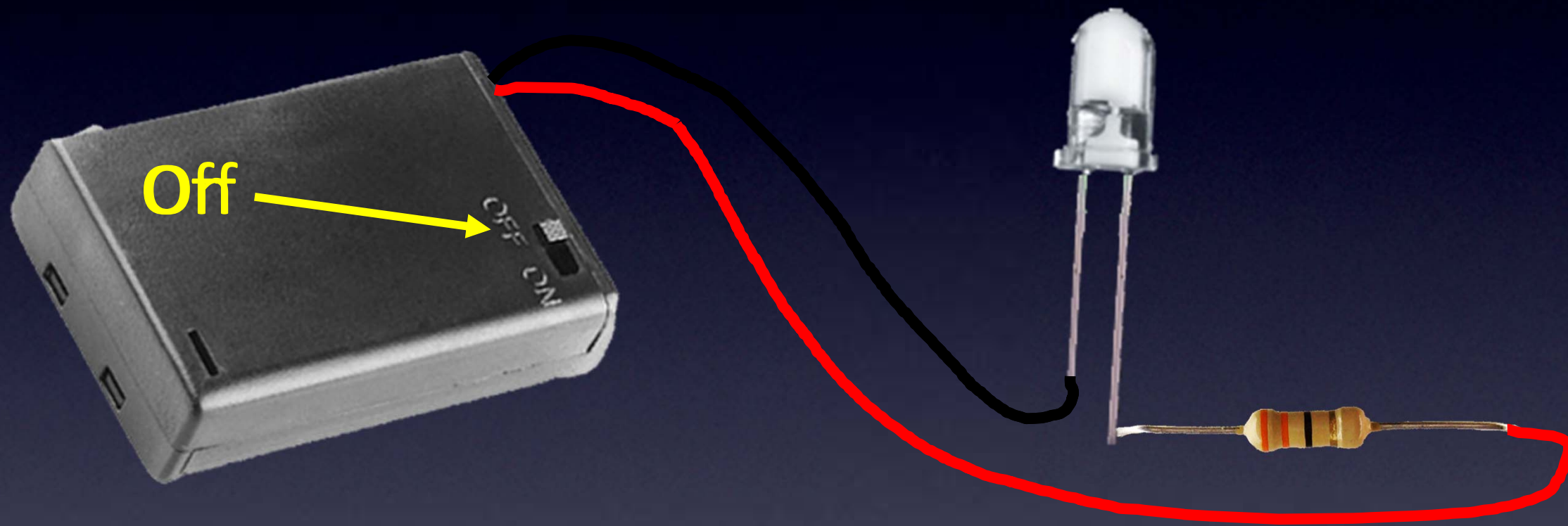

It's off

LED

Everything You Need to Know About Electronics

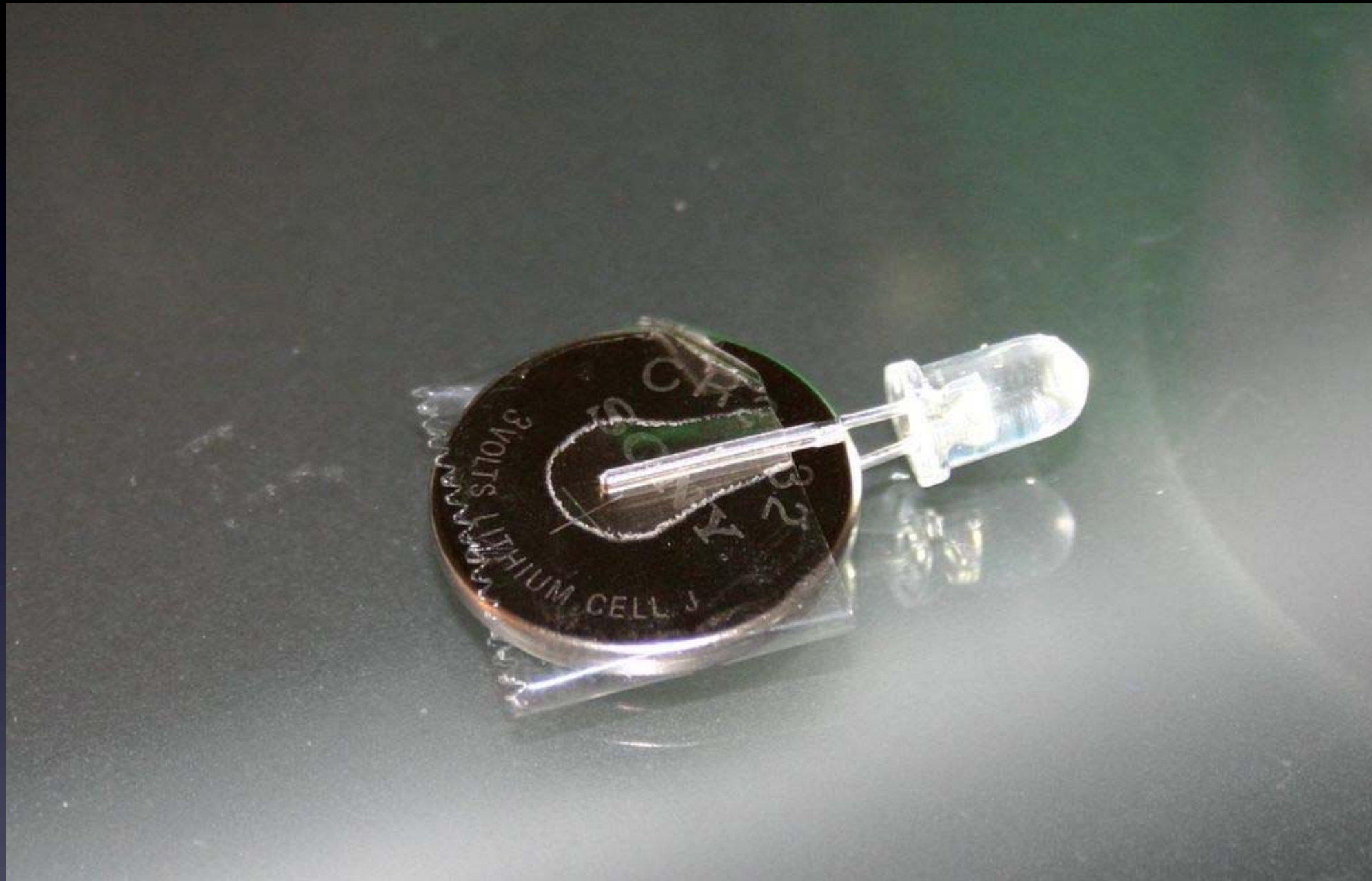

LED & battery

Our first circuit

Everything You Need to Know About Electronics

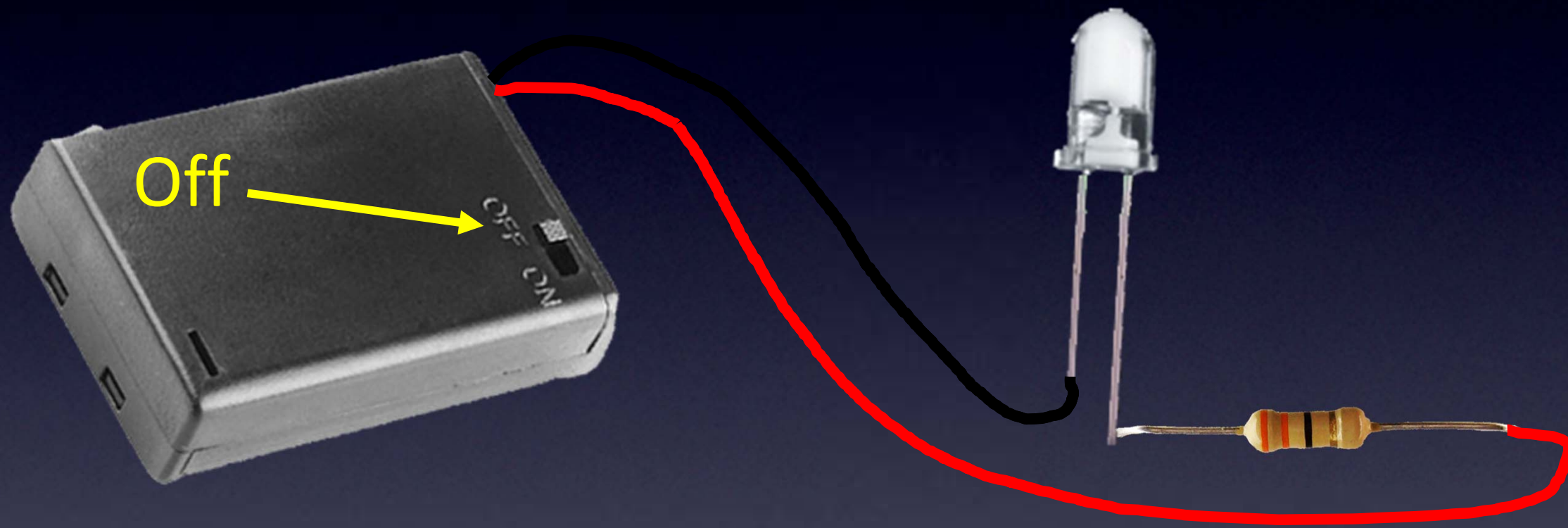

IR LED

Everything You Need to Know About Electronics

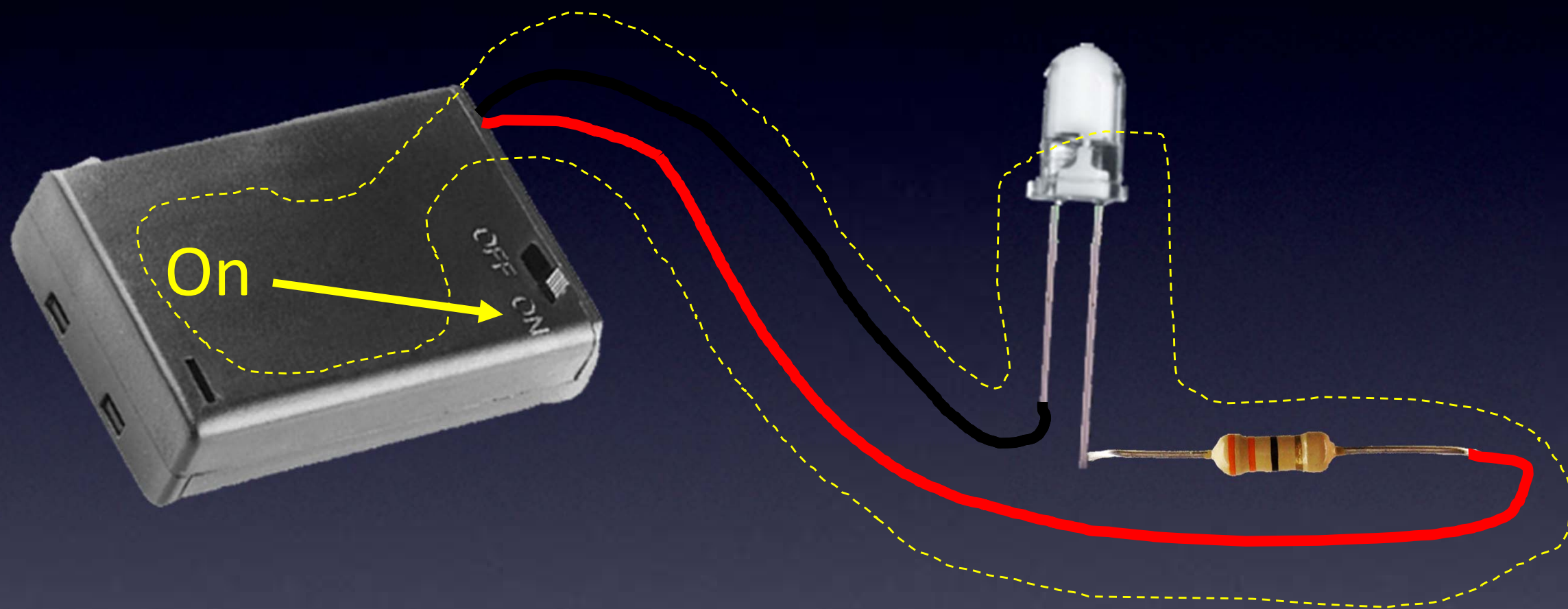

IR LED

Everything You Need to Know About Electronics

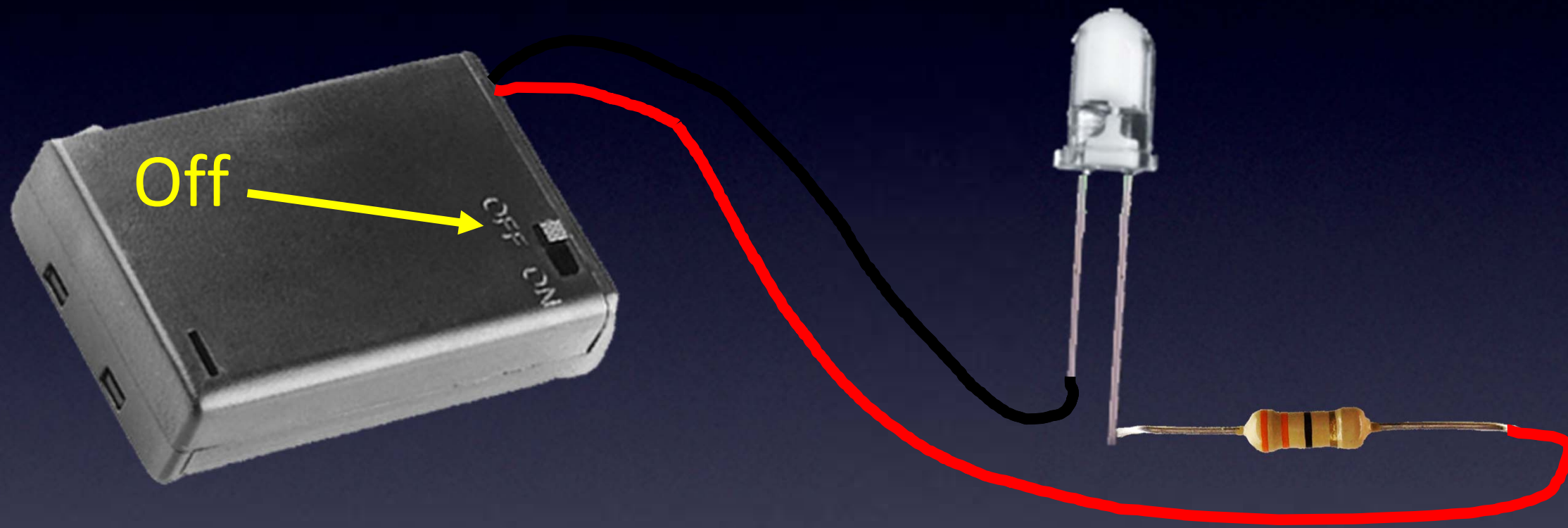

IR LED

Everything You Need to Know About Electronics

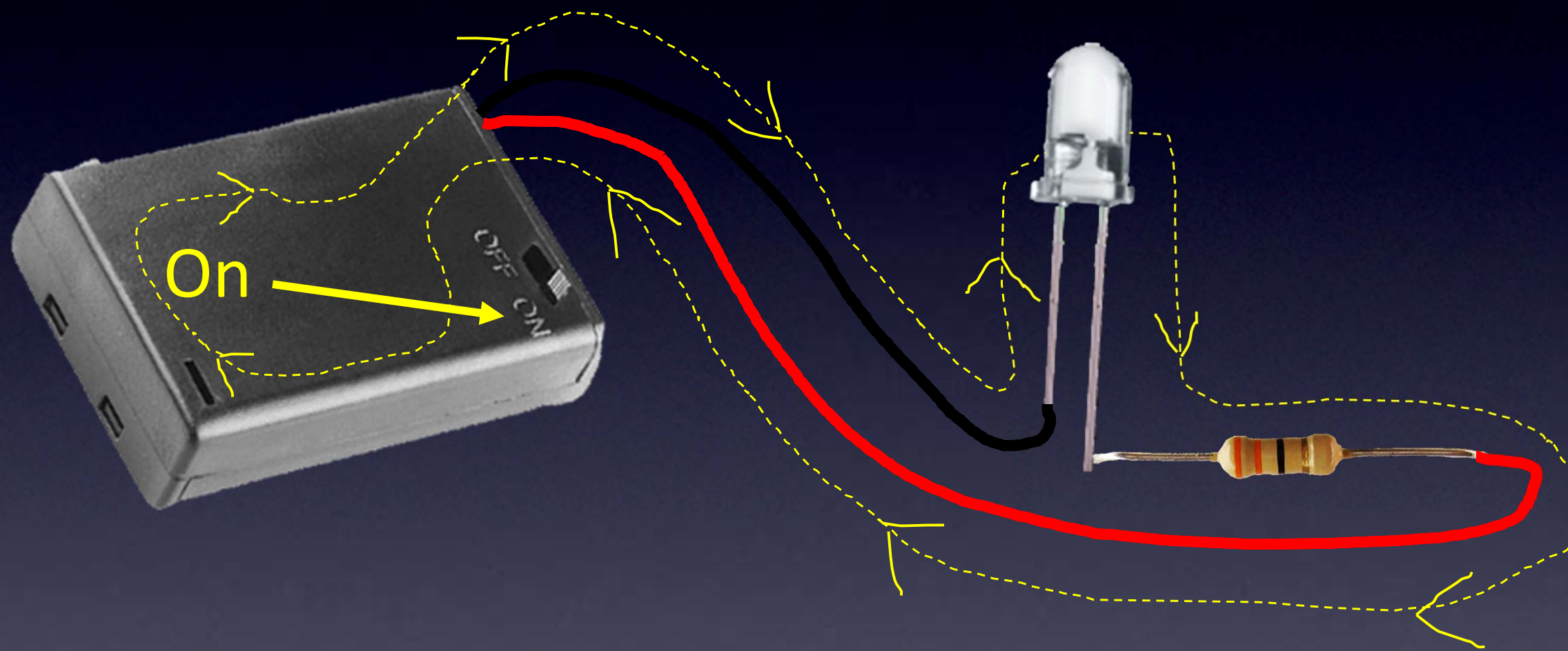

IR LED

Everything You Need to Know About Electronics

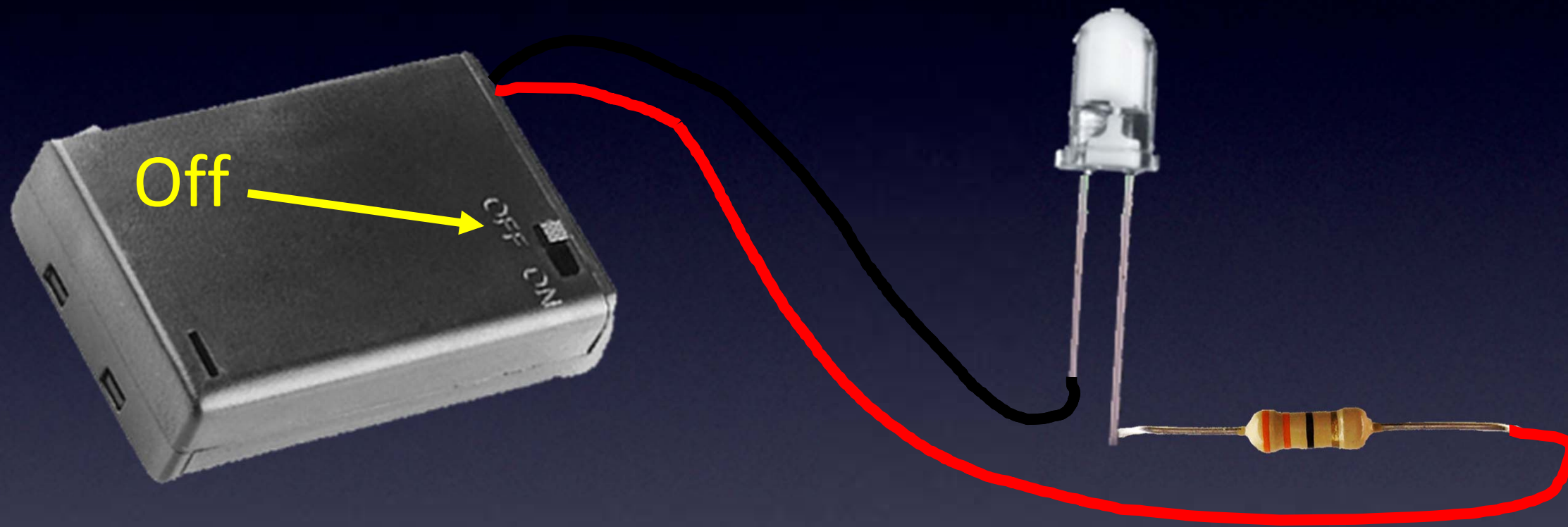

A “code” is IR light blinking on-off-on-off...

IR Remote Control

Everything You Need to Know About Electronics

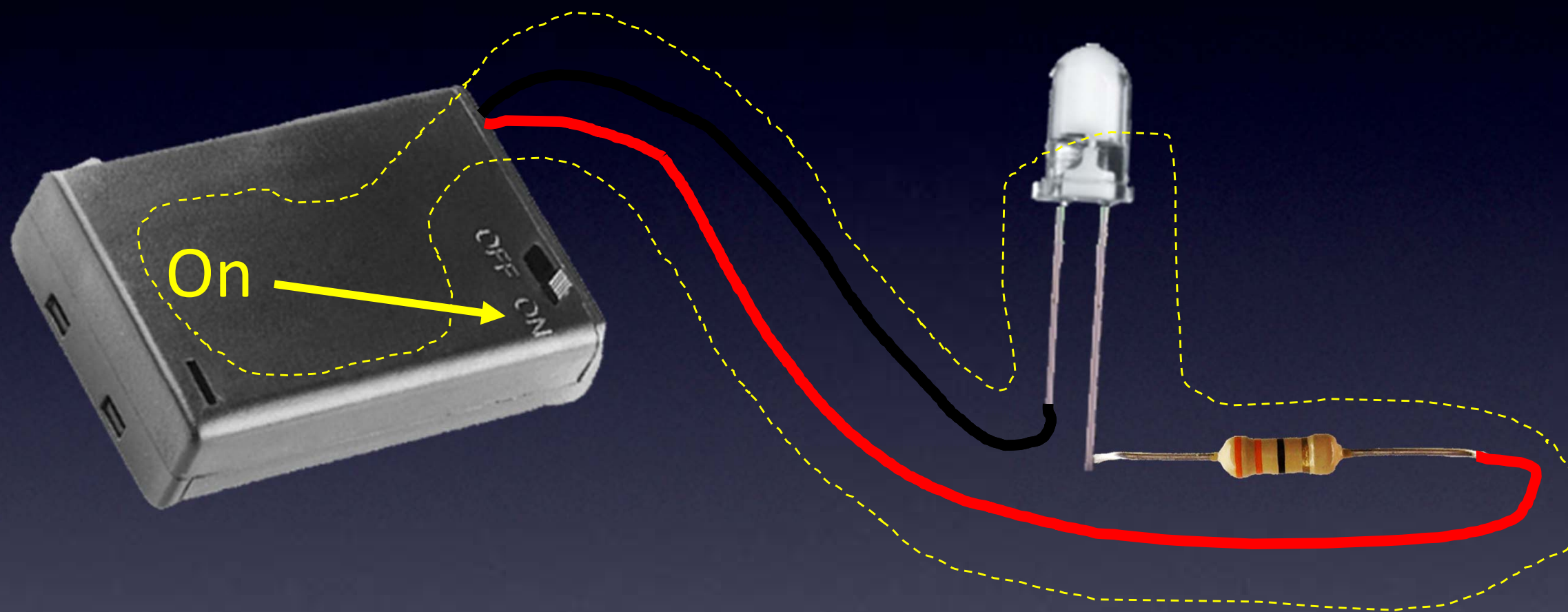

A “code” is IR light blinking on-off-on-off...

(we can't do this, but microcontrollers can!)

IR Remote Control

Everything You Need to Know About Electronics

Takes about 60 seconds

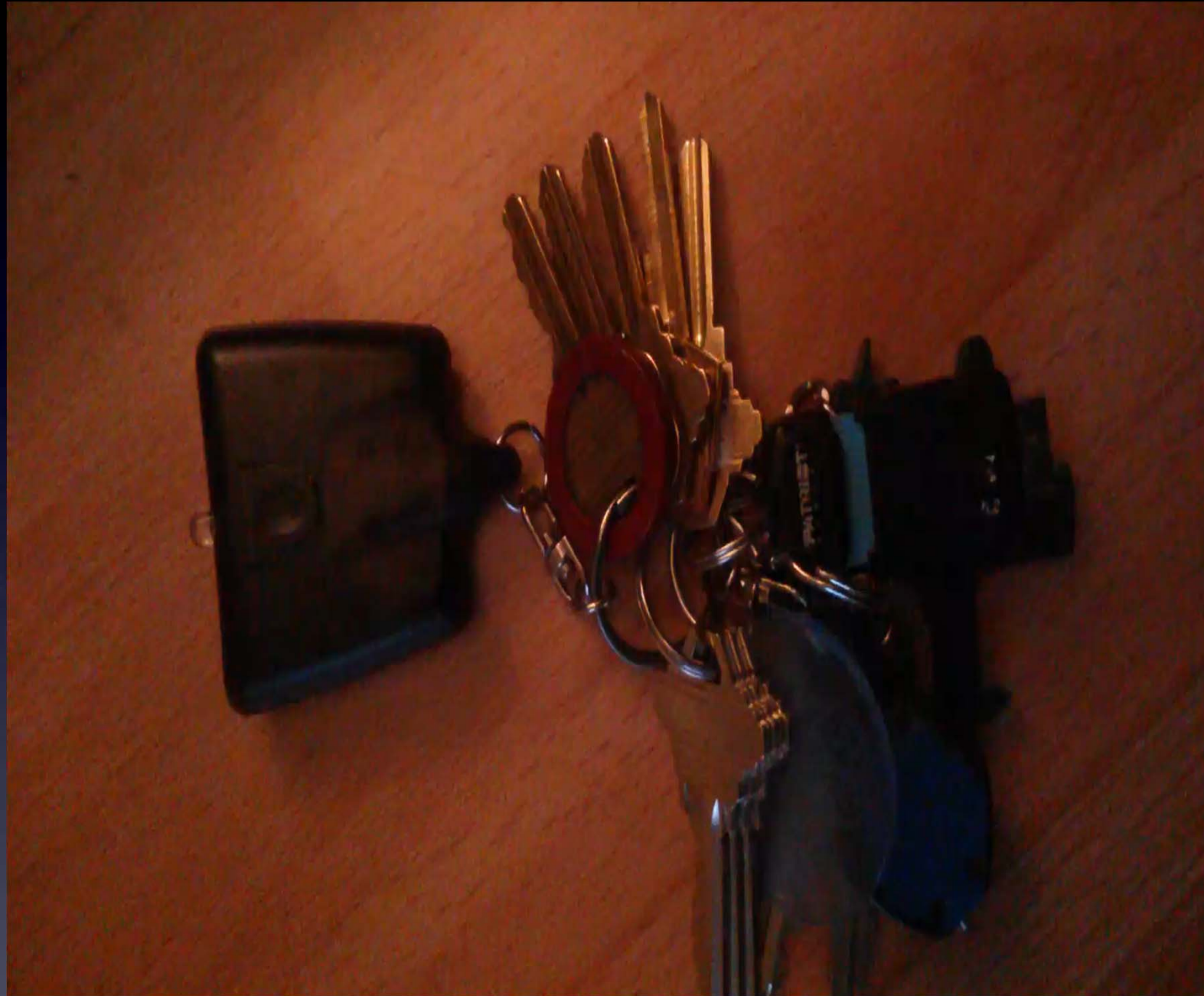

About 150 IR "OFF" codes (one per blink)

TV-B-Gone universal remote control

Everything You Need to Know About Electronics

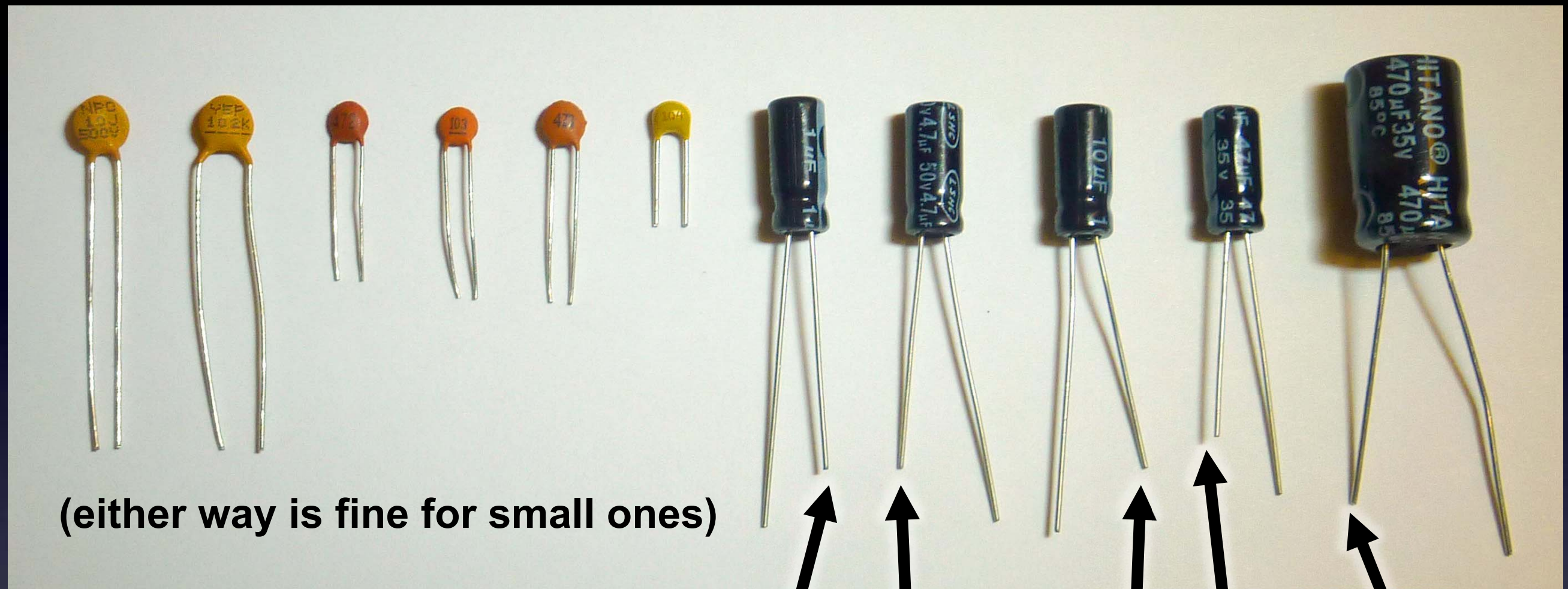

(either way is fine for small ones)

Short wire is Minus / Negative

Little buckets for electrons

Capacitor / Farads

Everything You Need to Know About Electronics

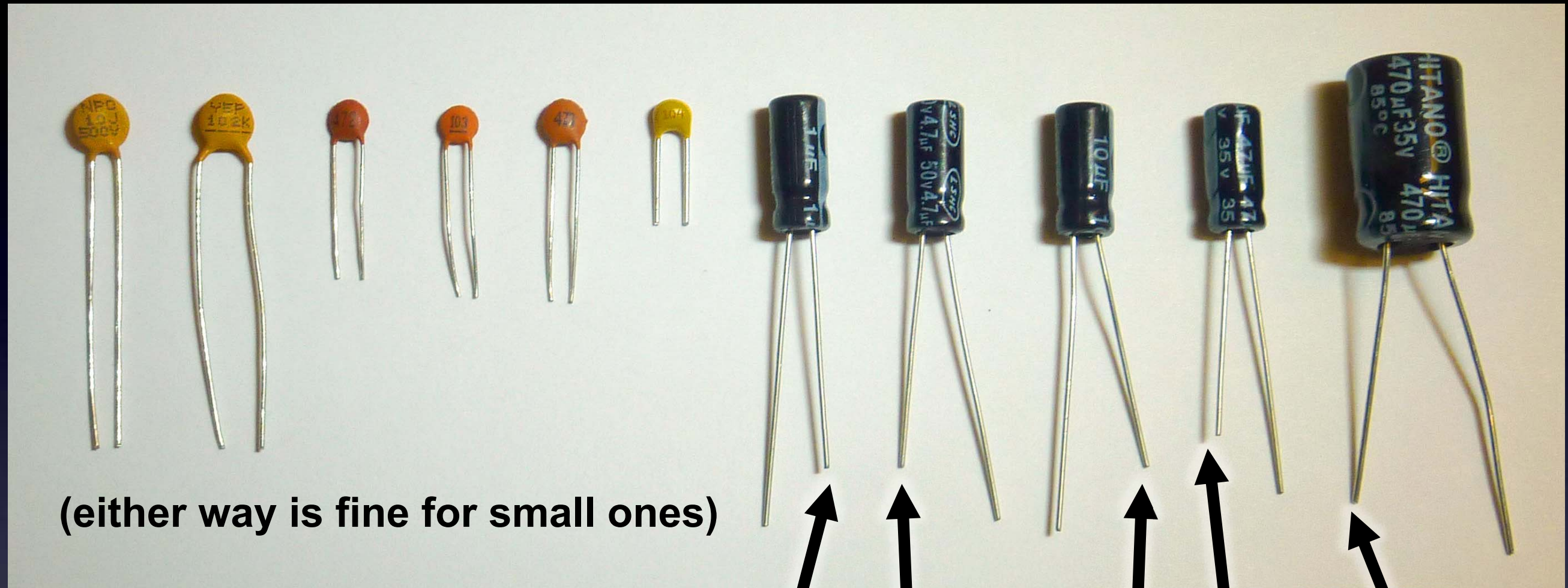

Short wire is Minus / Negative

Little buckets for electrons

Capacitor / Farads

Everything You Need to Know About Electronics

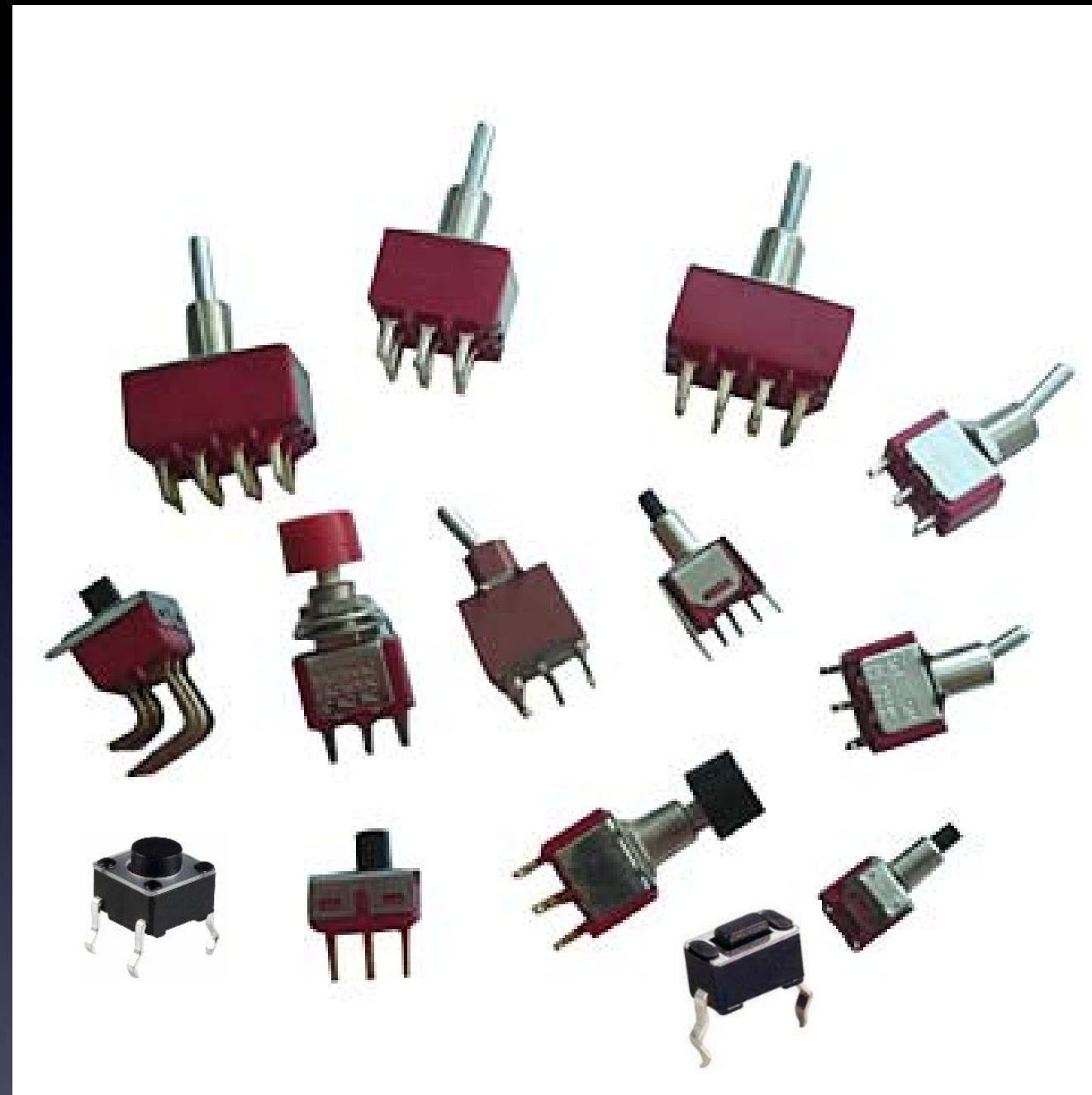

Strips of metal connected together – or not

Switch

Everything You Need to Know About Electronics

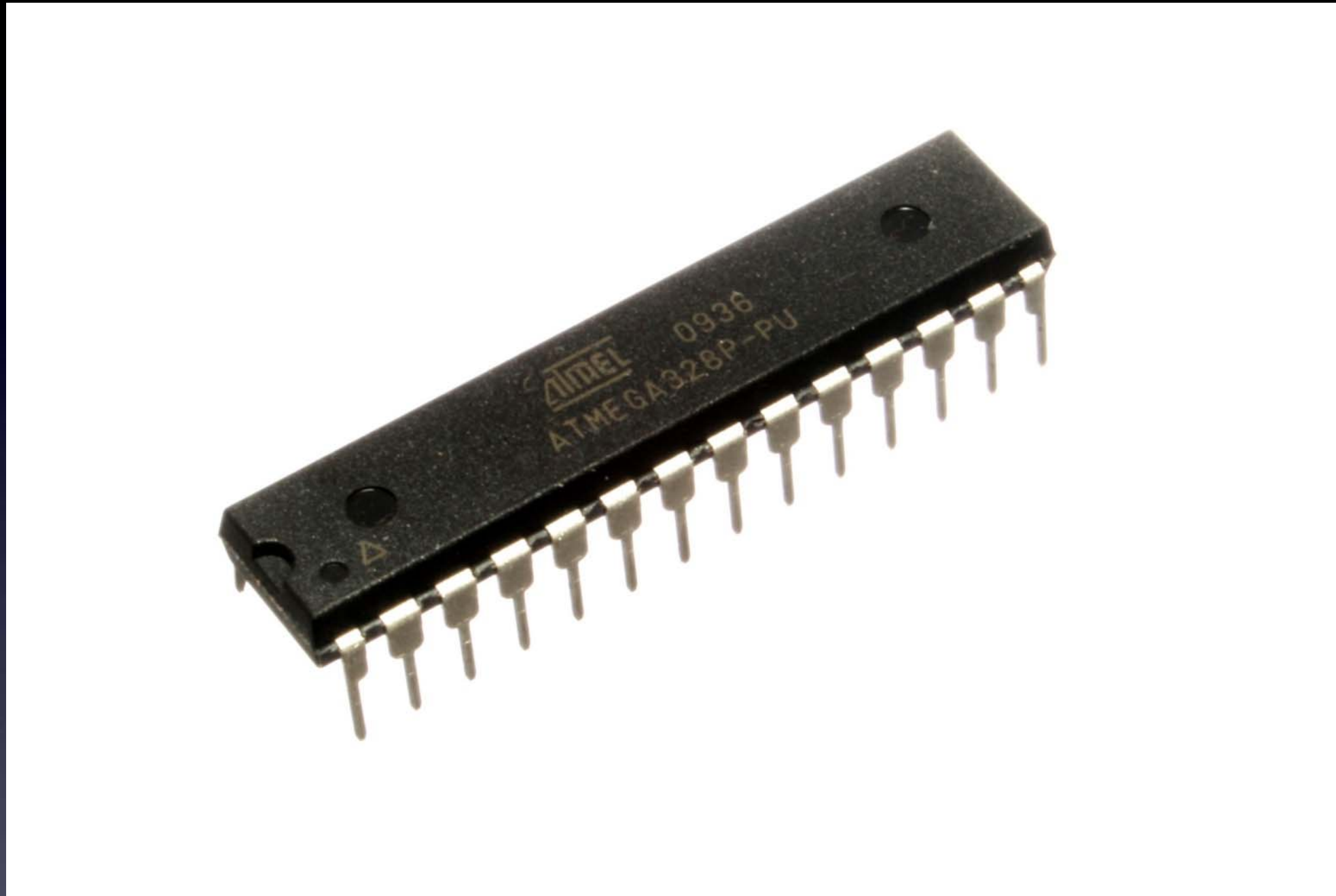

A complete computer on a chip

Microcontroller

Everything You Need to Know About Electronics



that control electronic parts connected to its pins.

Microcontroller

Everything You Need to Know About Electronics

2 special pins:

Pin 1

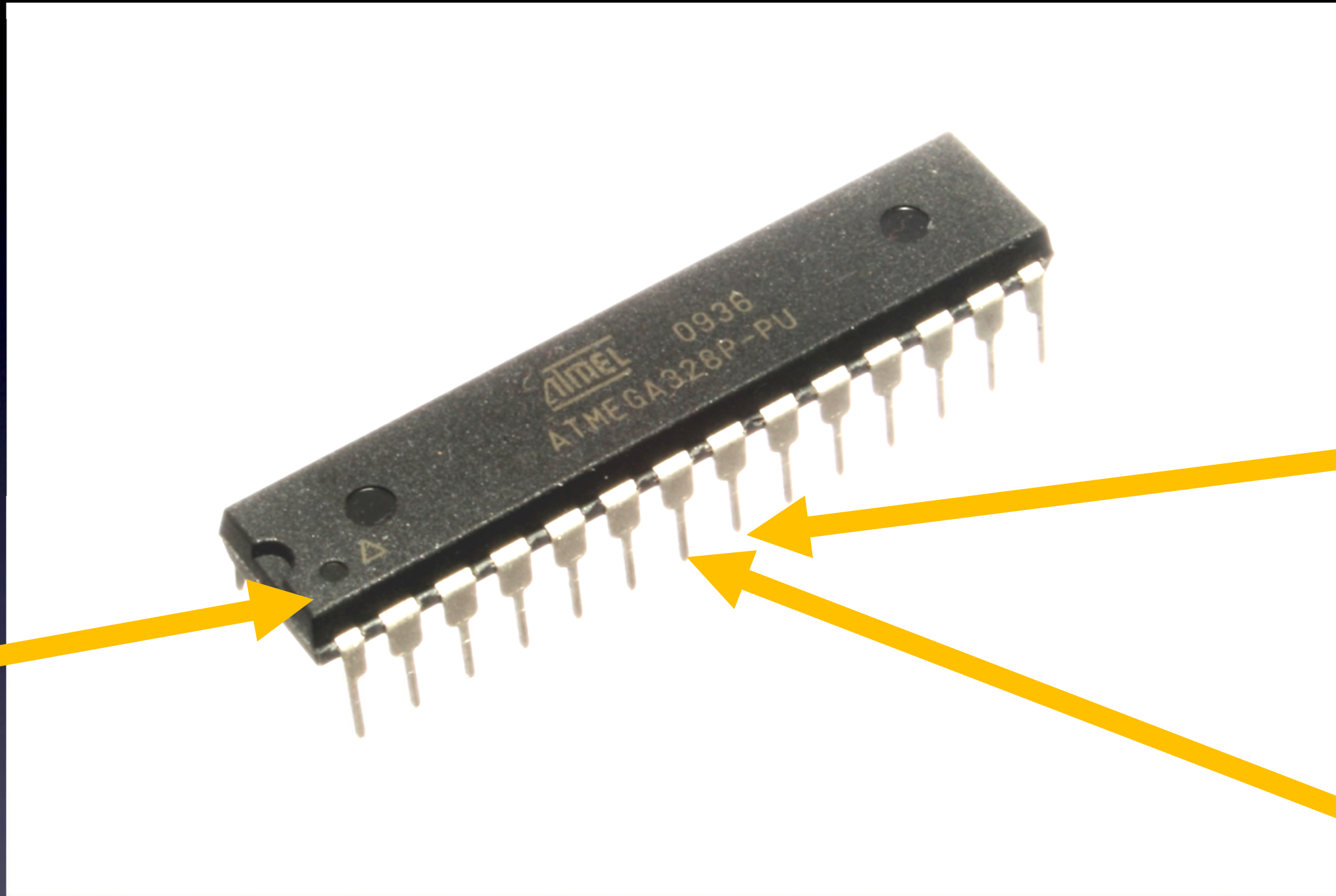

**Pin 8 =
Ground**

**Pin 7 =
Vcc**

A complete computer on a chip

Microcontroller – it matters how you hook it up!

Everything You Need to Know About Electronics

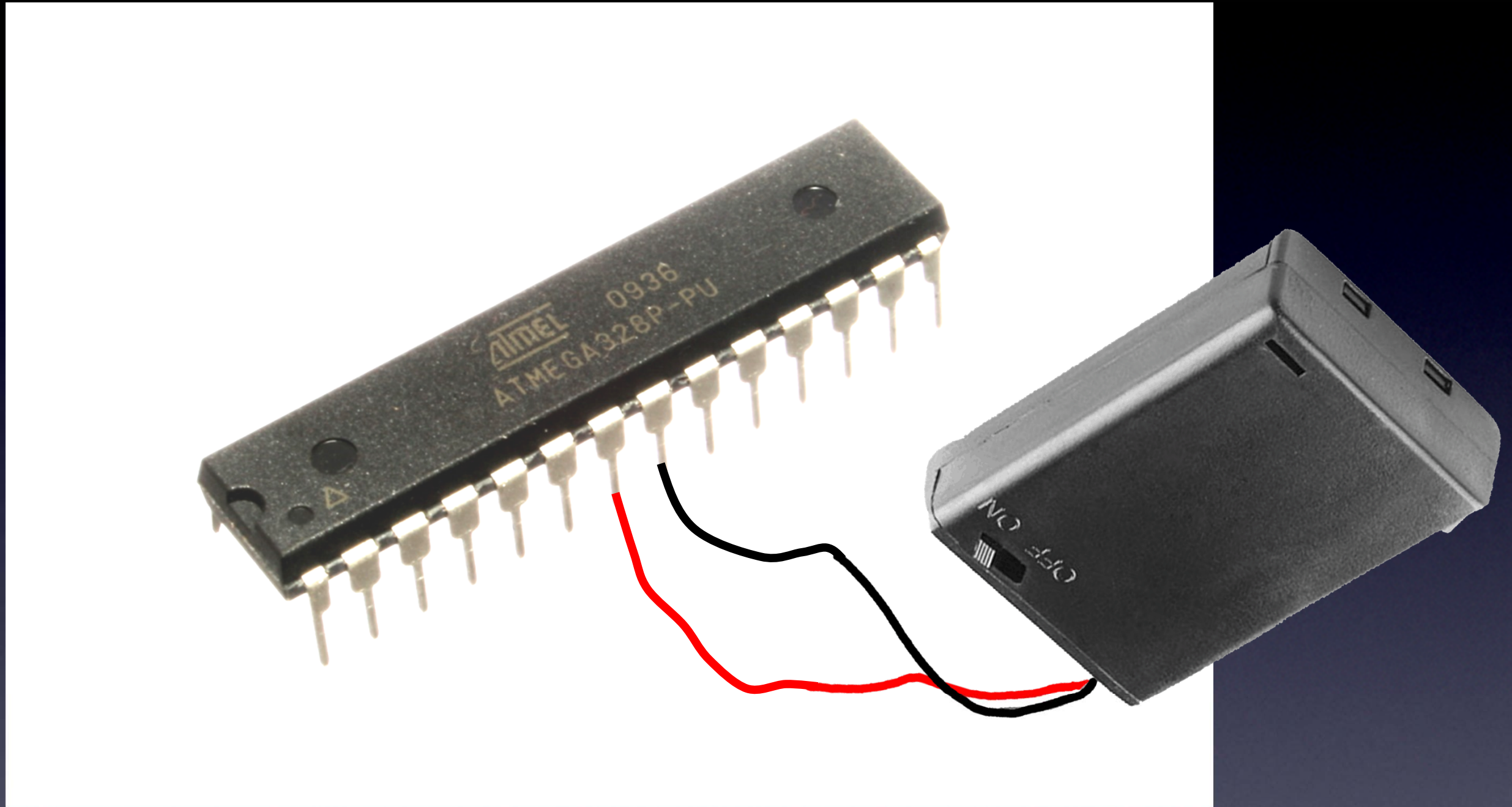

A complete computer – running a program!

Microcontroller – turned on!

Everything You Need to Know About Electronics

**all other pins are
Input pins
or
Output pins**

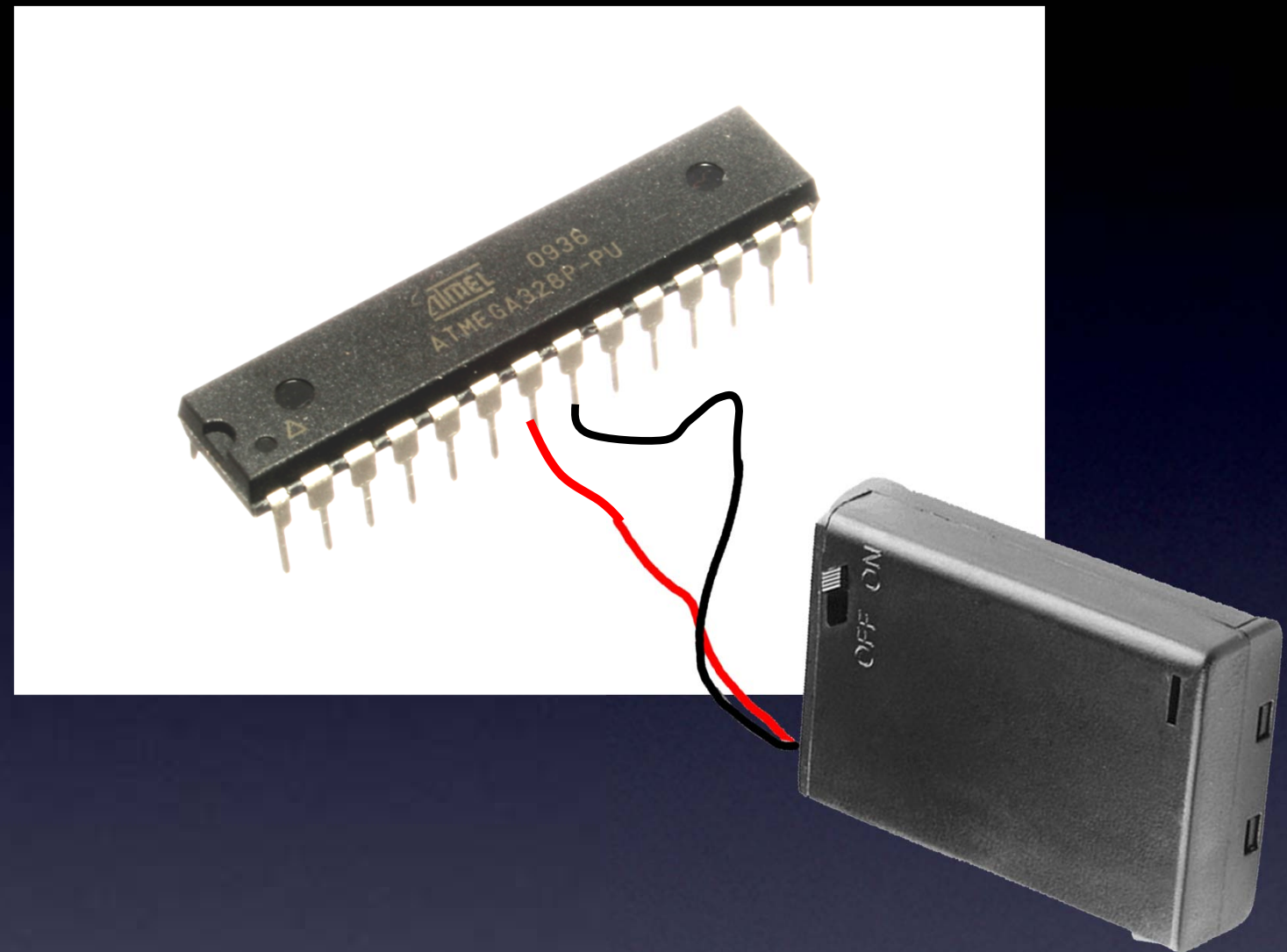

**Your program controls electronics parts
on these other pins**

Microcontroller

Everything You Need to Know About Electronics

Analog Electronics:

Any voltage between Ground (0V) and V_{cc}

Digital Electronics:

Only 2 choices: Ground (0V) or V_{cc}

2 types of electronics

Everything You Need to Know About Electronics

Ground (0V)

Low

Off

0

Power / Vcc

High

On

1

(without Voltage / with Voltage)

(without current / with current)

Digital Electronics:

Only 2 choices: Ground (0V) or Vcc

Digital Electronics

Everything You Need to Know About Electronics

To make a pin an
Output pin

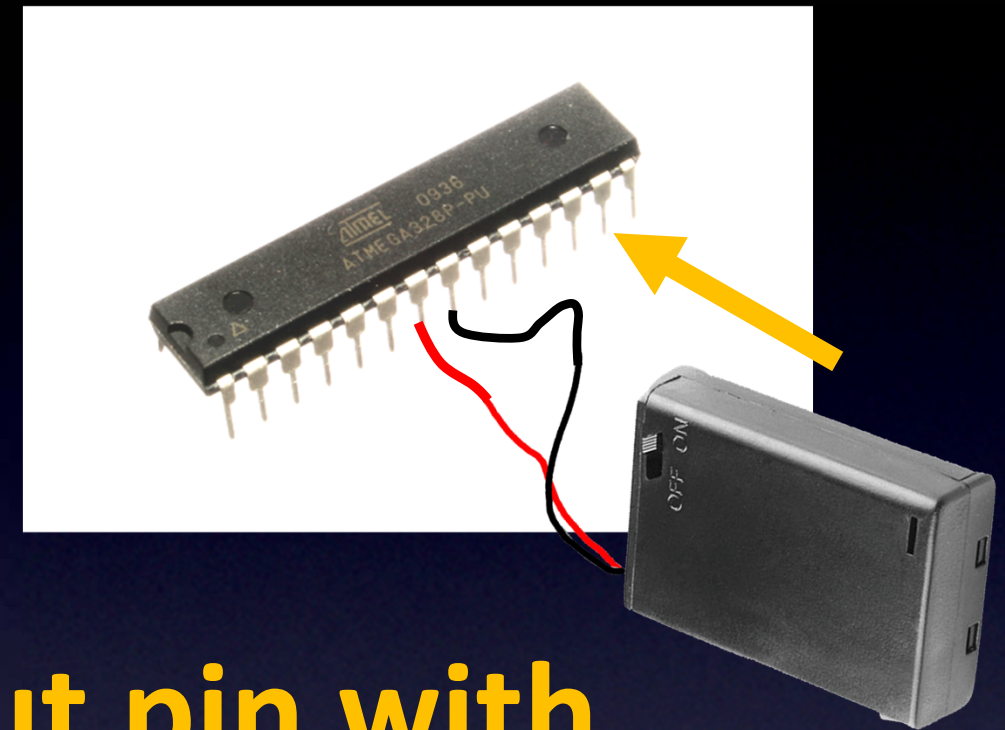

you tell it to become an **Output pin** with
a statement in your program

Let's tell pin 13 to be an **Output pin**

Microcontroller – Output pins

Everything You Need to Know About Electronics

Low

Off

(0V)

High

On

(Power supply voltage)

**-- like the Red wire of our power supply
-- *but controlled by our program!***

Only 2 choices: High or Low

Microcontroller – Output pins

Everything You Need to Know About Electronics

A real world example

How to make an LED blink?

`Hello World`

Microcontroller

Everything You Need to Know About Electronics

Software

Type:

Hello World
on your screen

Microcontrollers

make an LED blink

Hello World

Microcontroller

Everything You Need to Know About Electronics

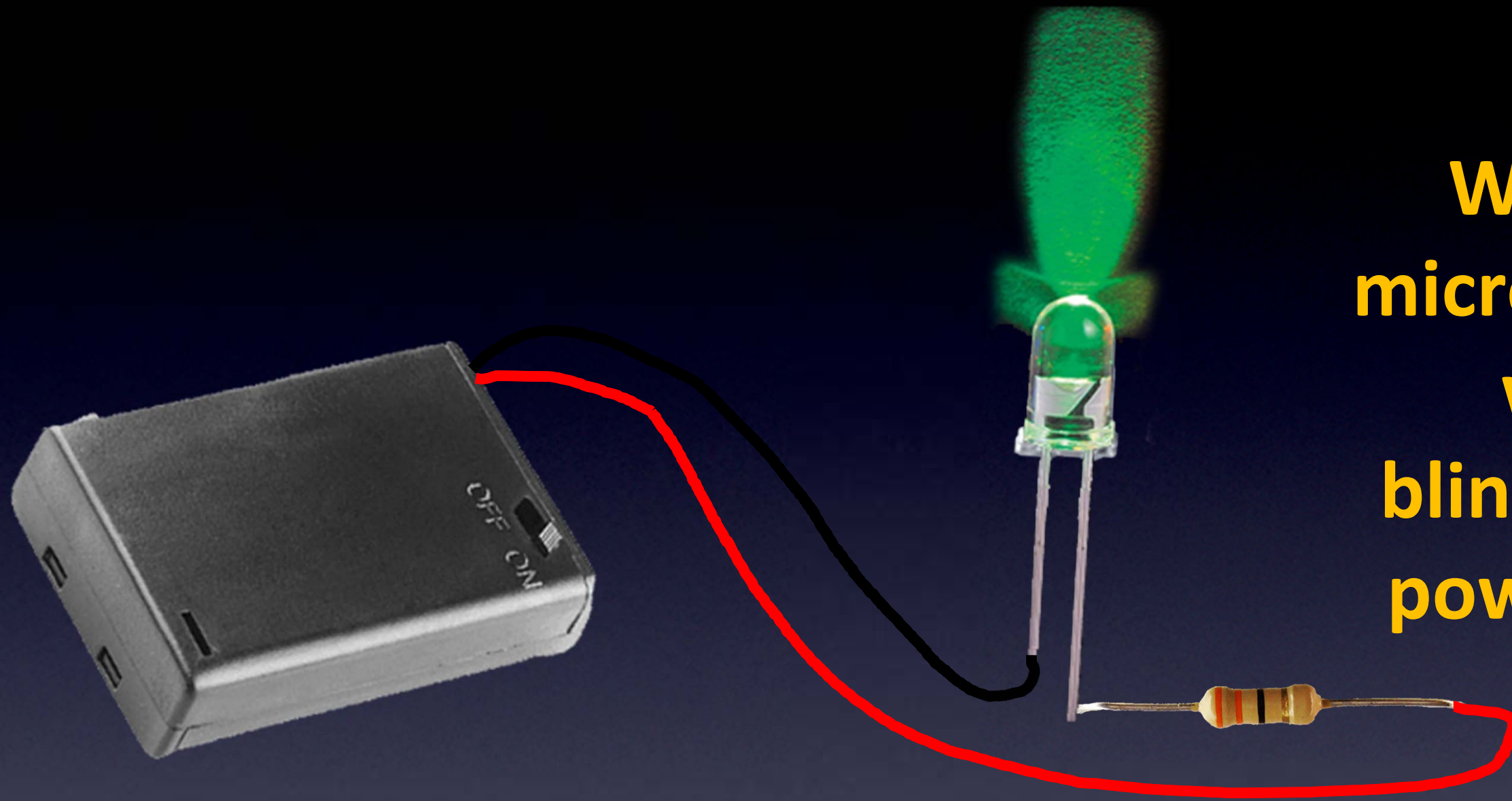

**Without a
microcontroller
we can
blink with our
power supply**

Turning an LED on and off

(Leading up to Hello World)

Everything You Need to Know About Electronics

**Let's replace
the power supply**

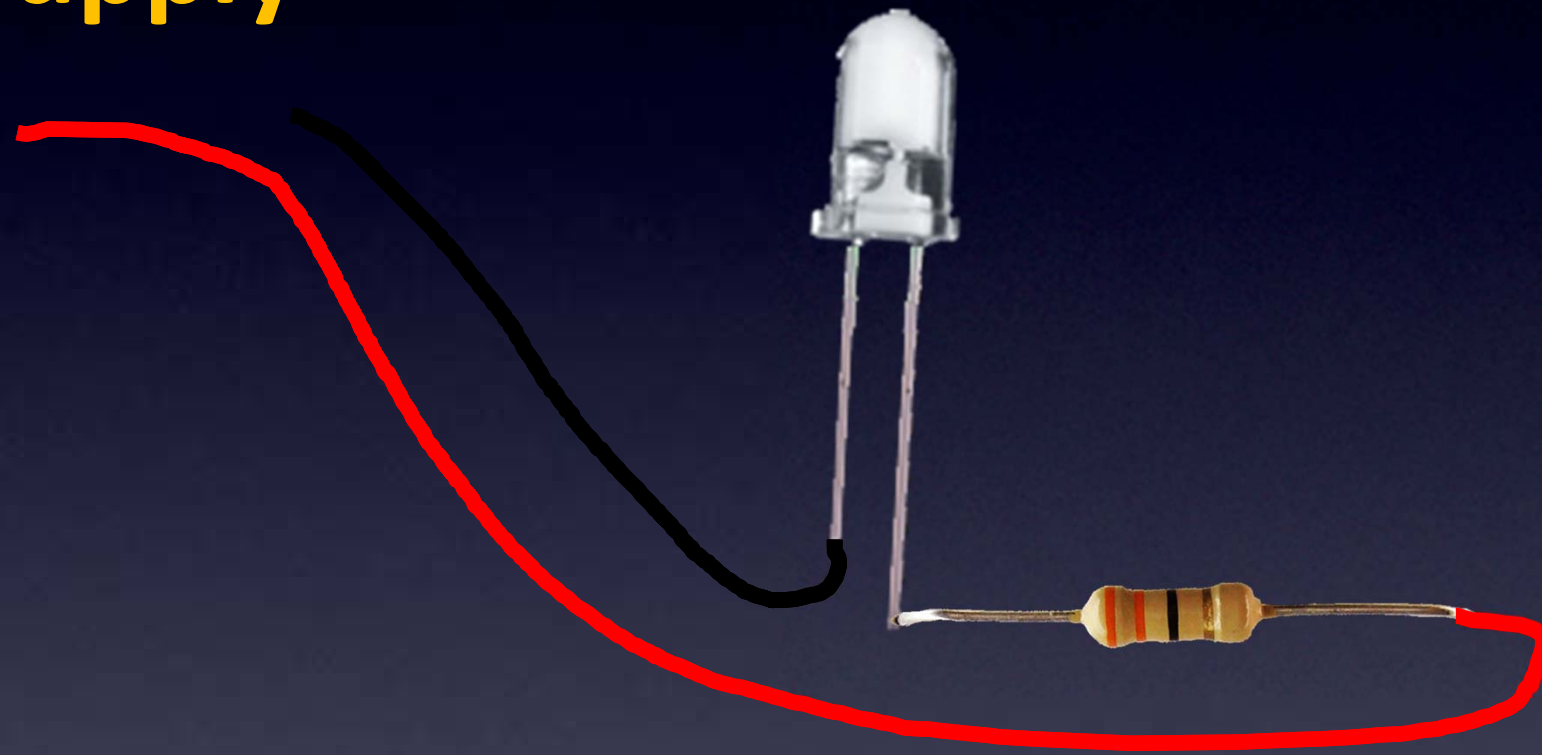

Turning an LED on and off

(Leading up to Hello World)

Everything You Need to Know About Electronics

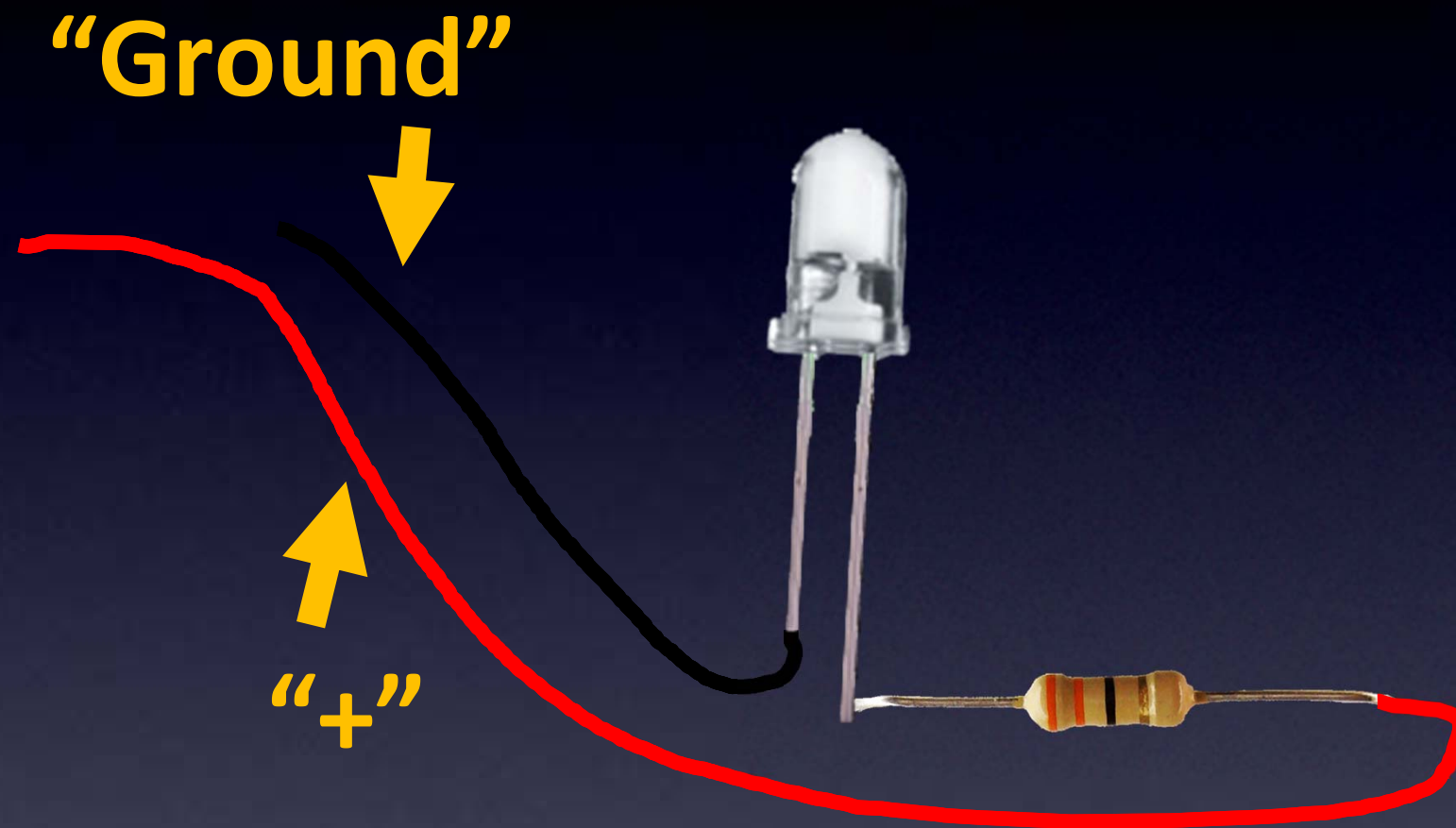

Turning an LED on and off

(Leading up to Hello World)

Everything You Need to Know About Electronics

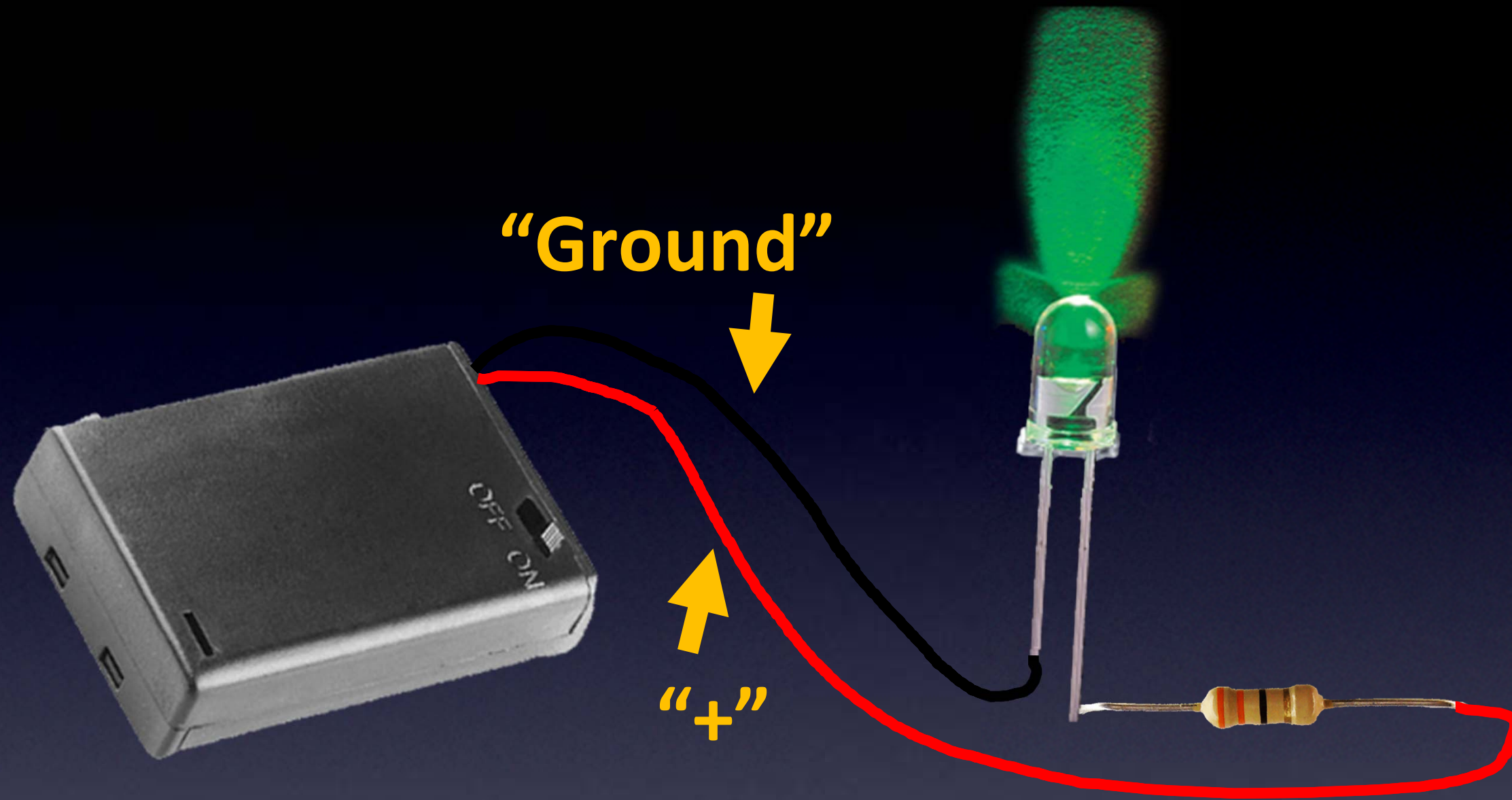

Turning an LED on and off

(Leading up to Hello World)

Everything You Need to Know About Electronics

We can use an
Output pin
(and Ground)
as our power
supply

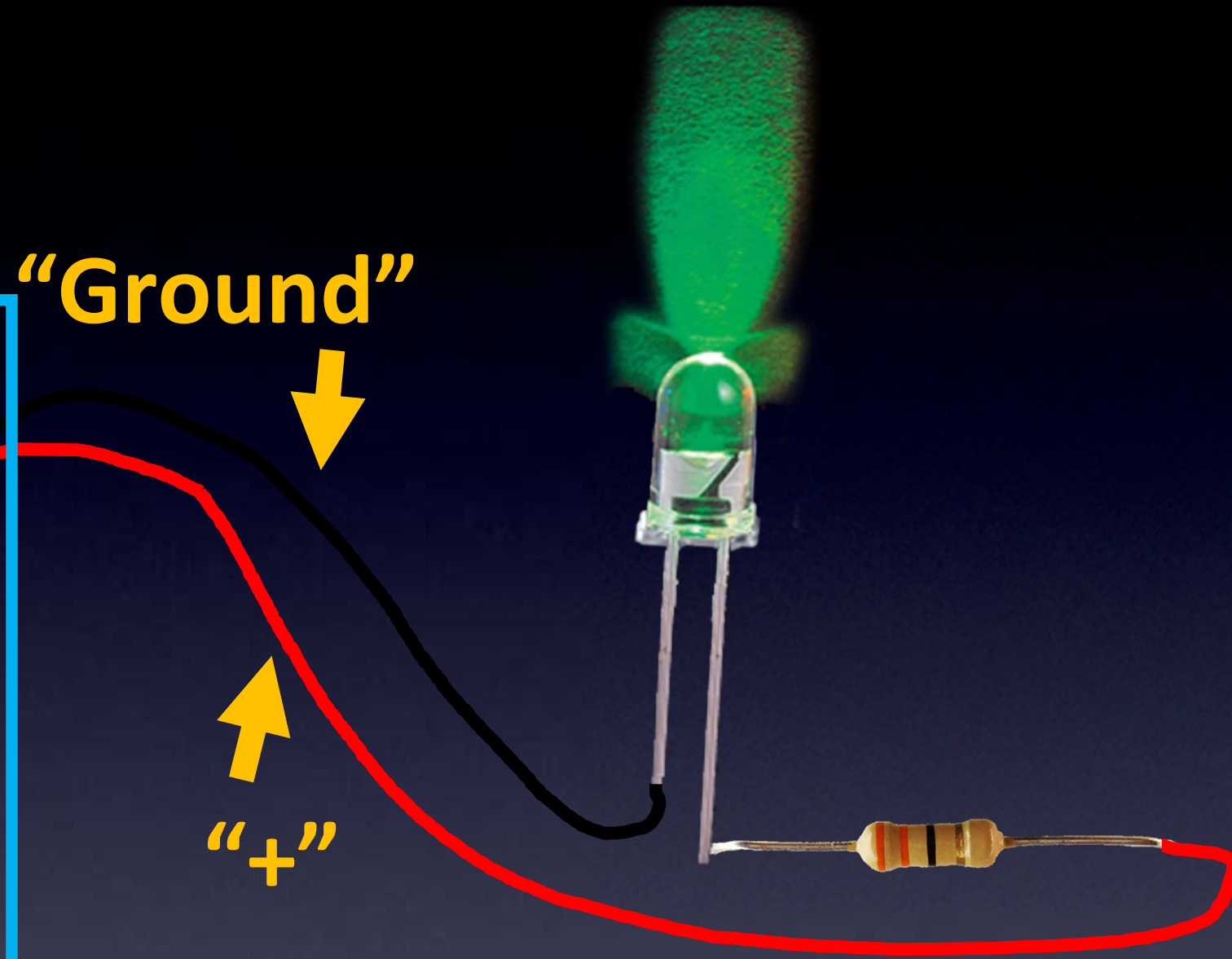

Turning an LED on and off

(Leading up to Hello World)

Everything You Need to Know About Electronics

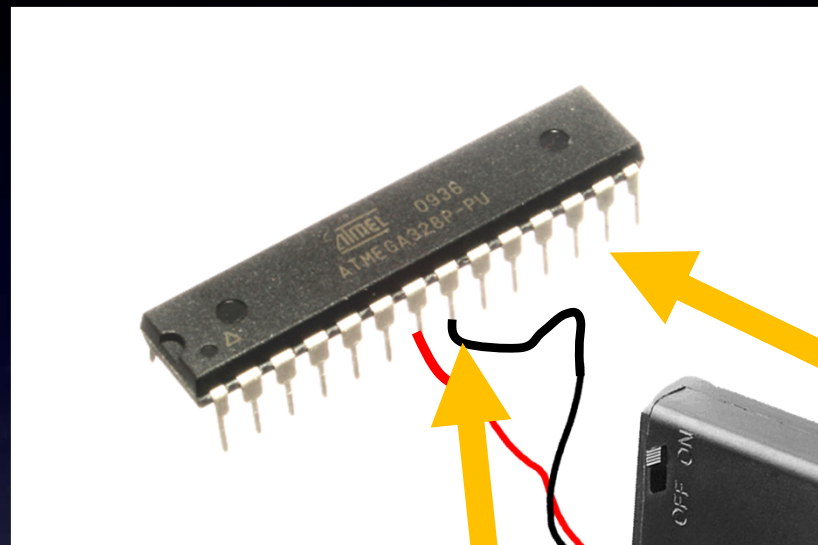

Ground

Let's use Pin 13
as our **Output pin**
(it can be High or Low)

Turning an LED on and off

(Leading up to Hello World)

Everything You Need to Know About Electronics

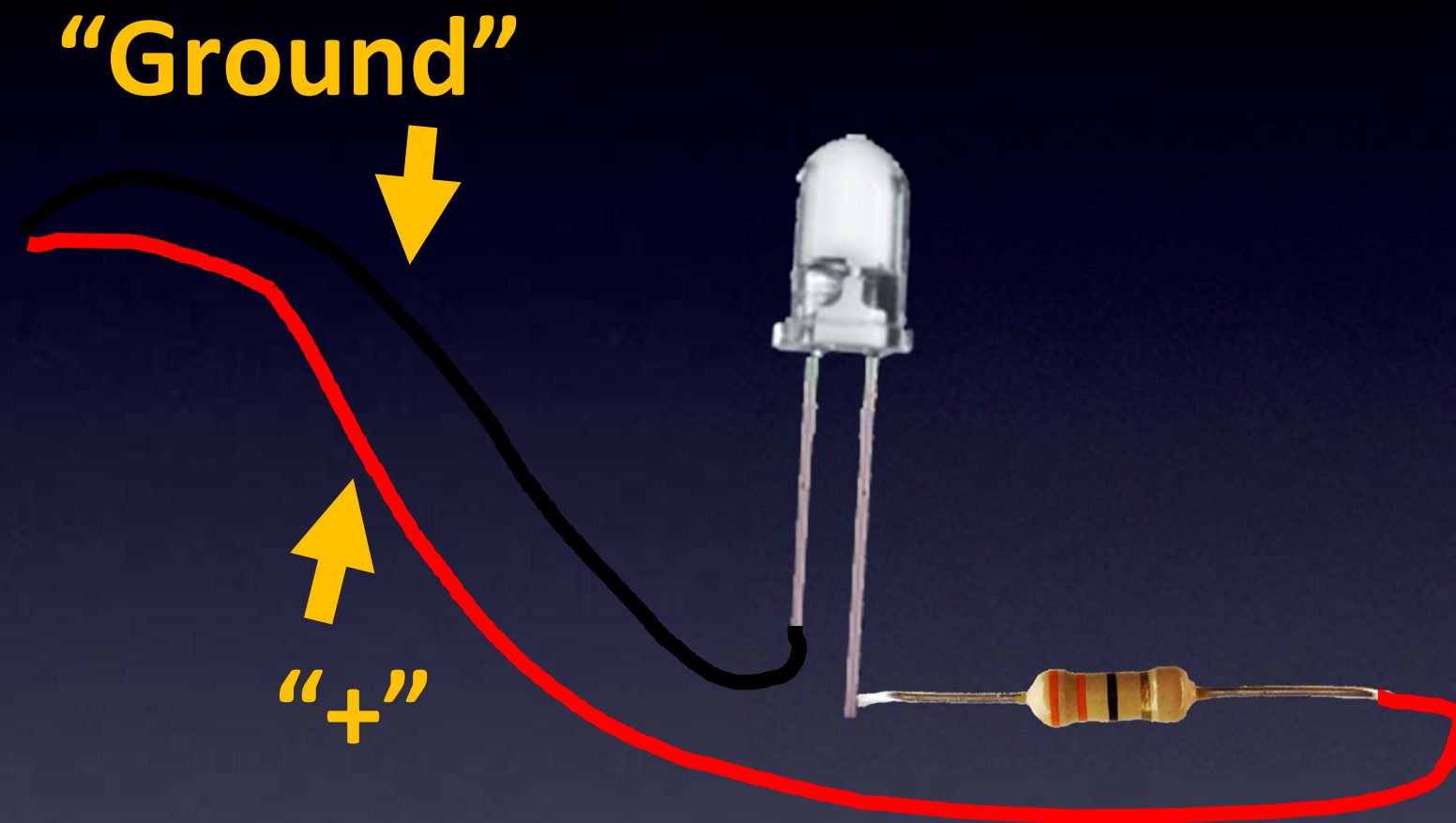

Turning an LED on and off

(Leading up to Hello World)

Everything You Need to Know About Electronics

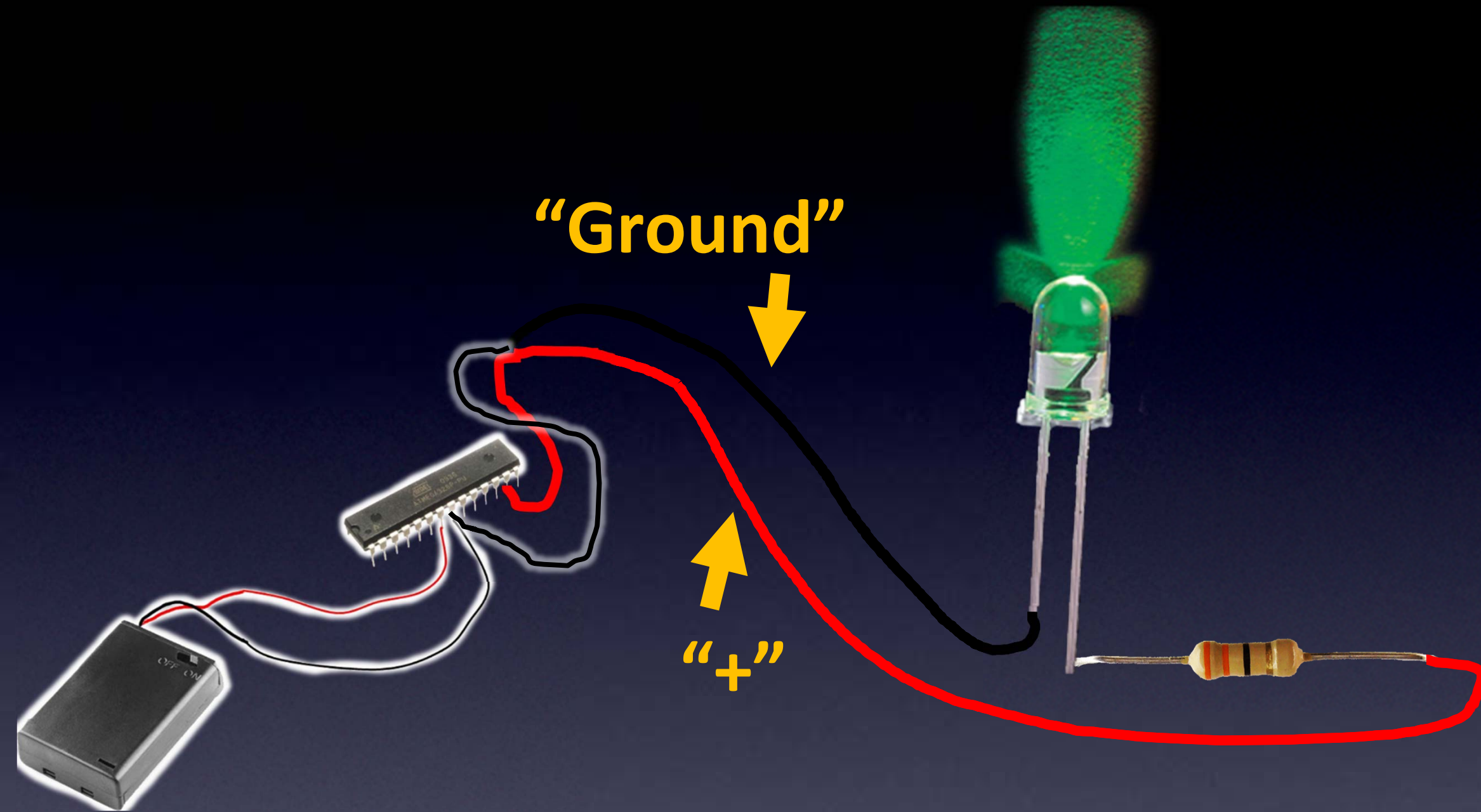

Turning an LED on and off

(Leading up to Hello World)

Everything You Need to Know About Electronics

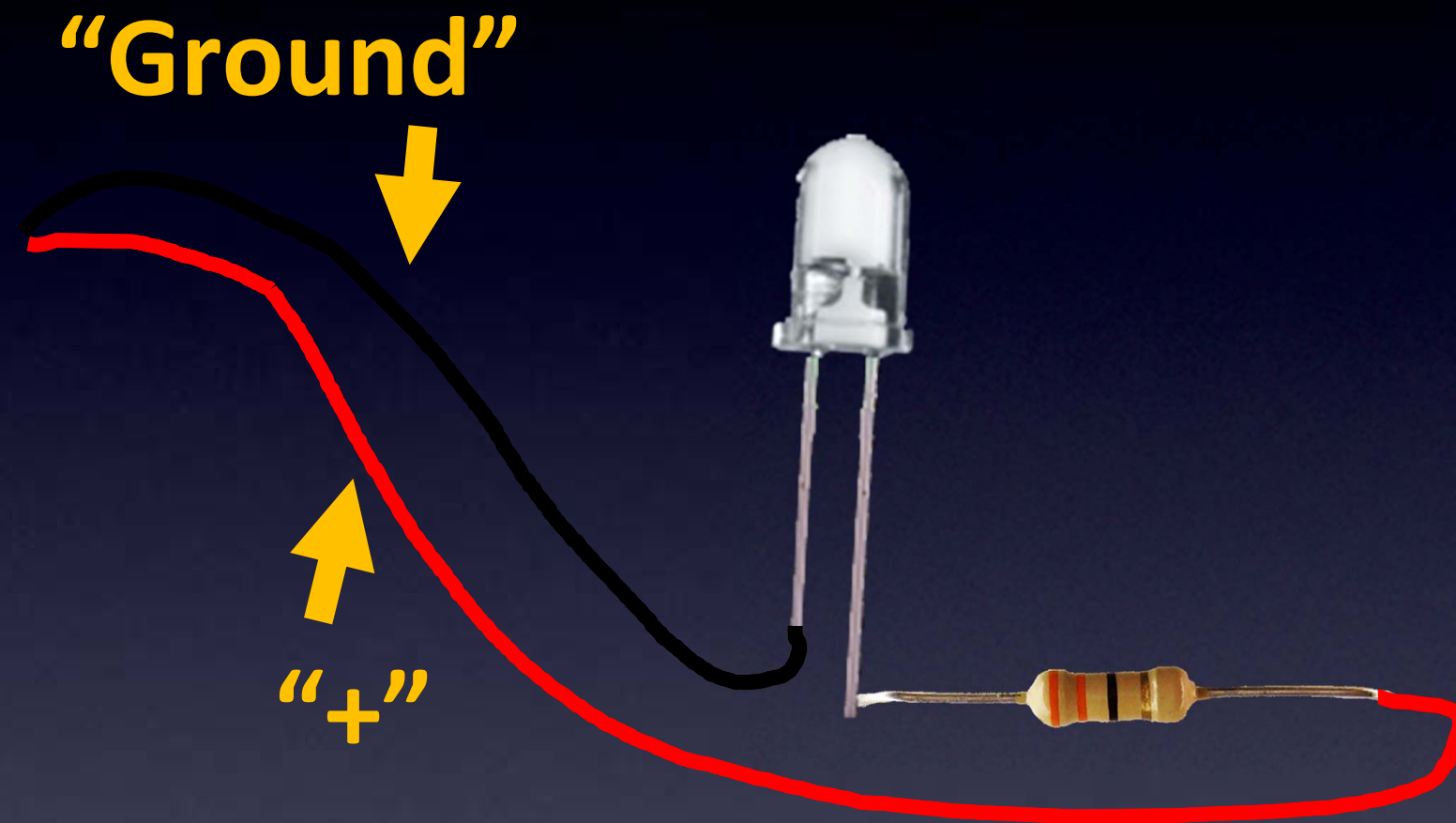

Turning an LED on and off

(Leading up to Hello World)

Everything You Need to Know About Electronics

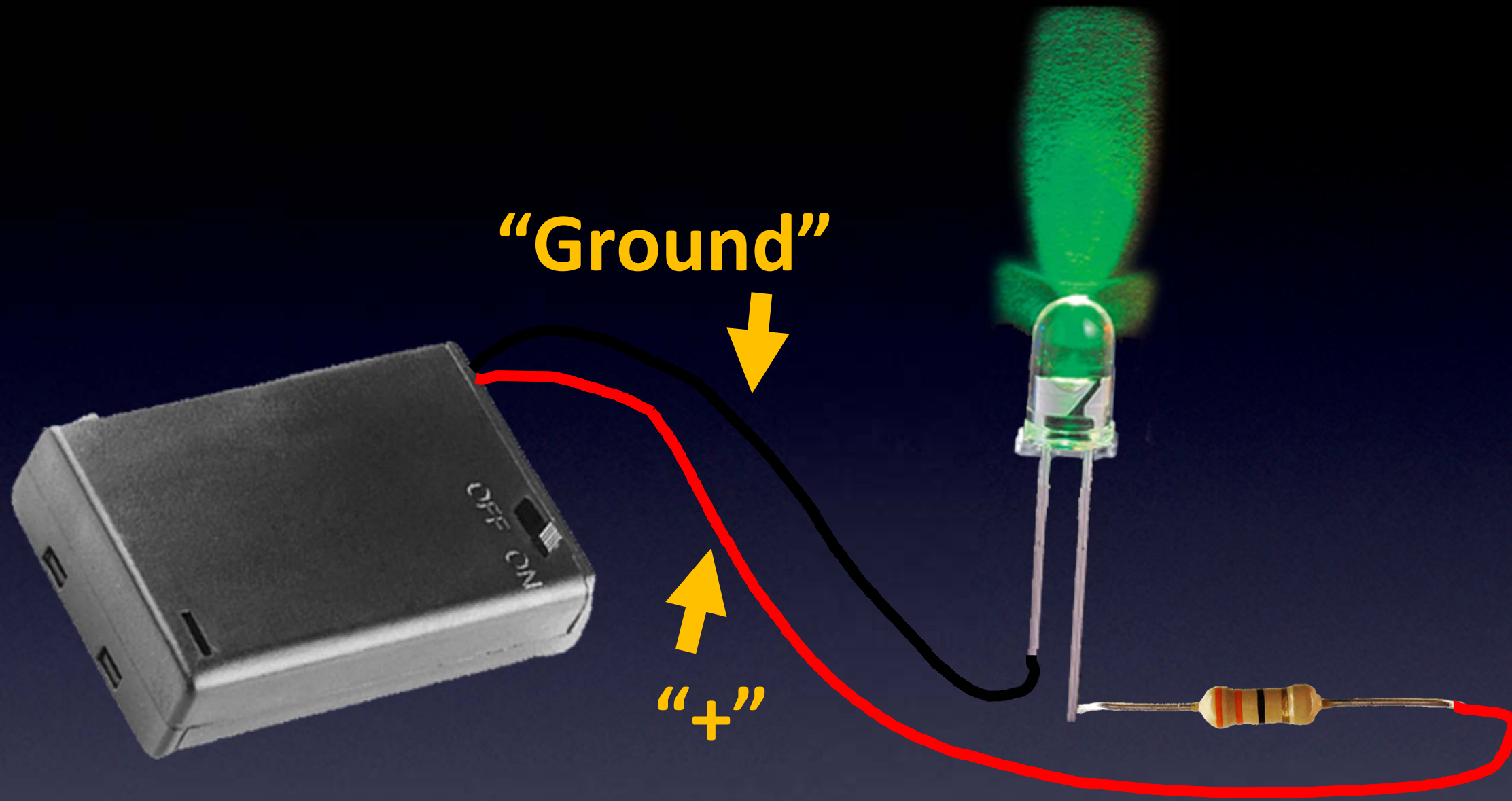

Turning an LED on and off

(Leading up to Hello World)

Everything You Need to Know About Electronics

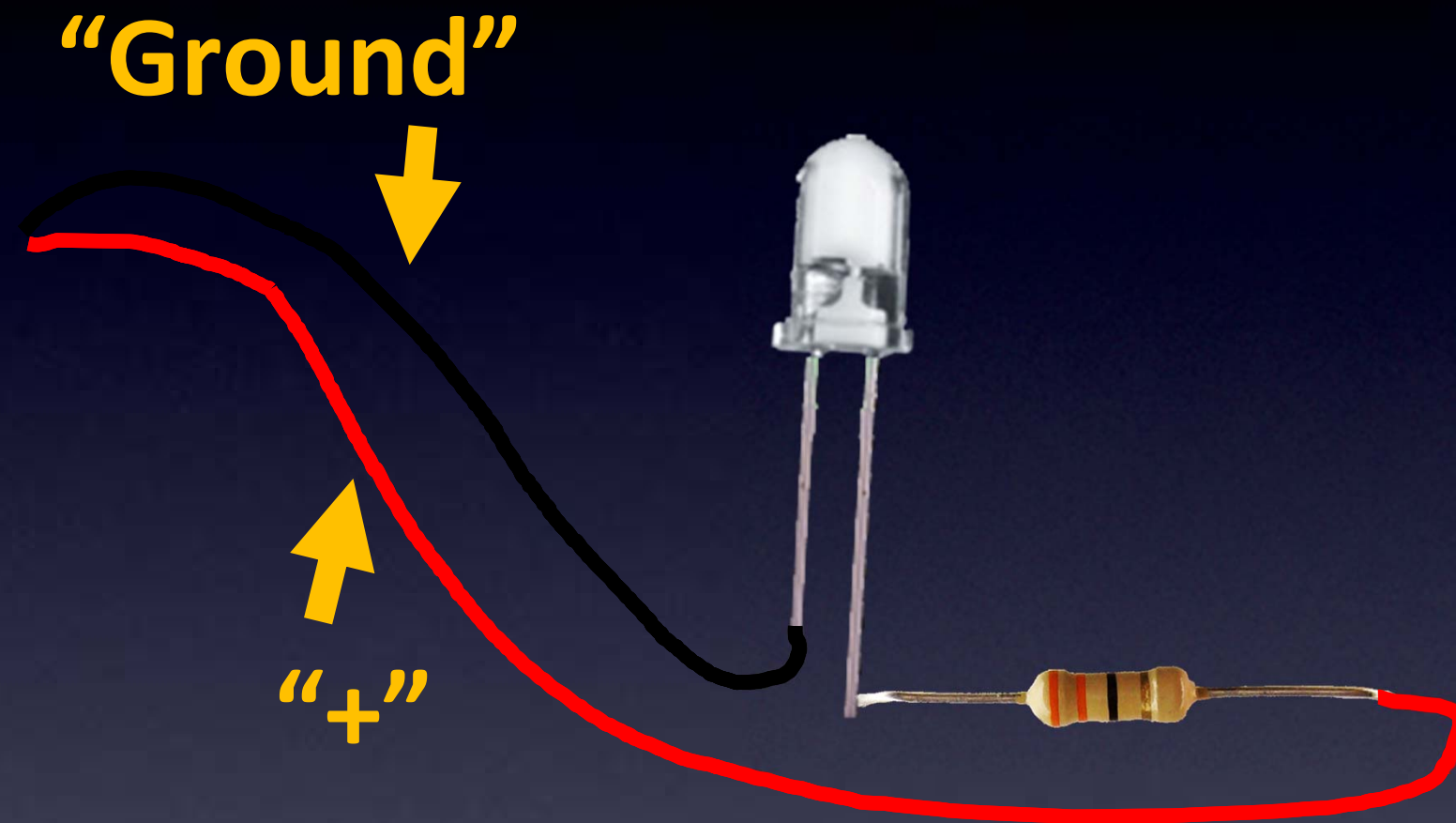

Turning an LED on and off

(Leading up to Hello World)

Everything You Need to Know About Electronics

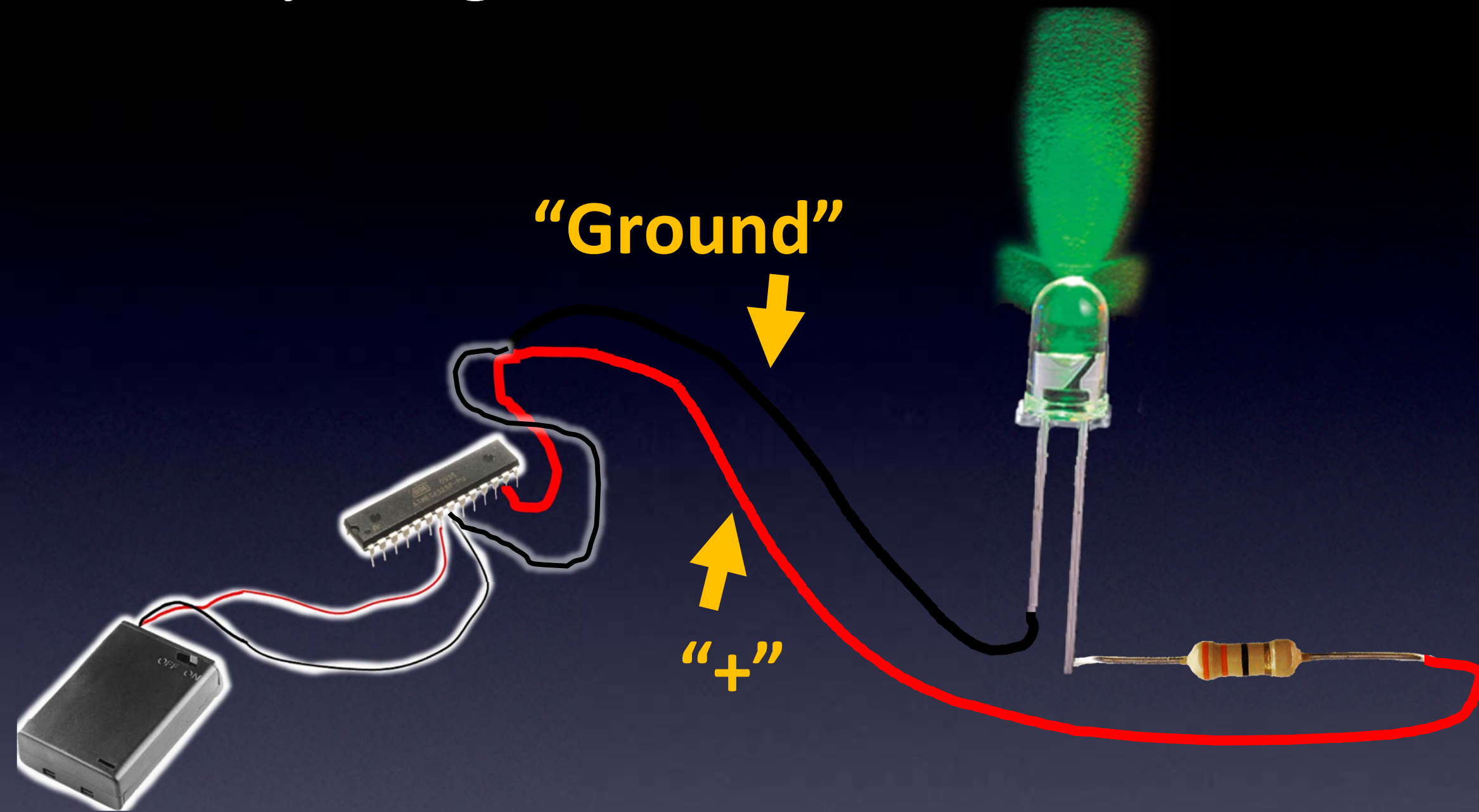

Turning an LED on and off

(Leading up to Hello World)

Everything You Need to Know About Electronics

This is our Hardware for Hello World!

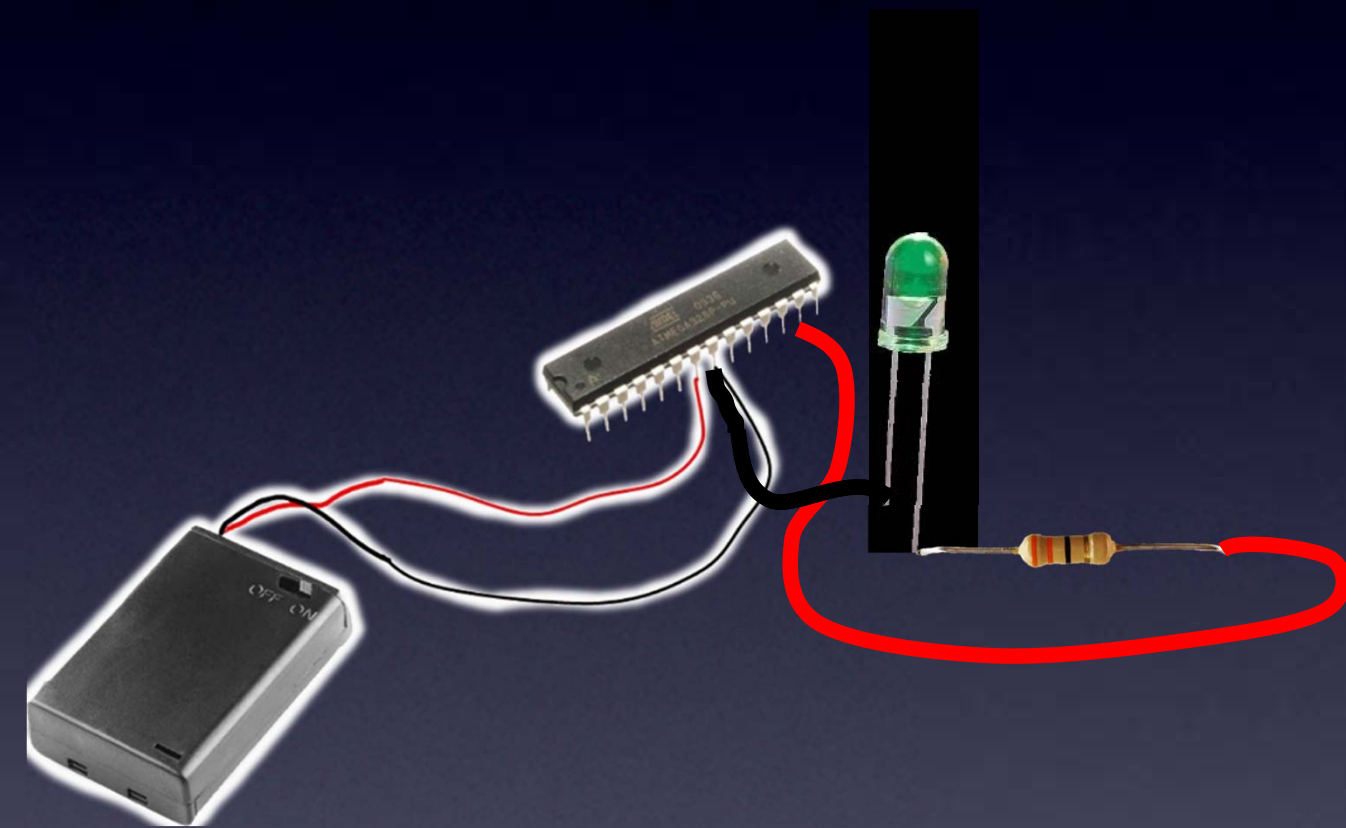

Turning an LED on and off

Hello World

Everything You Need to Know About Electronics

How about our program?

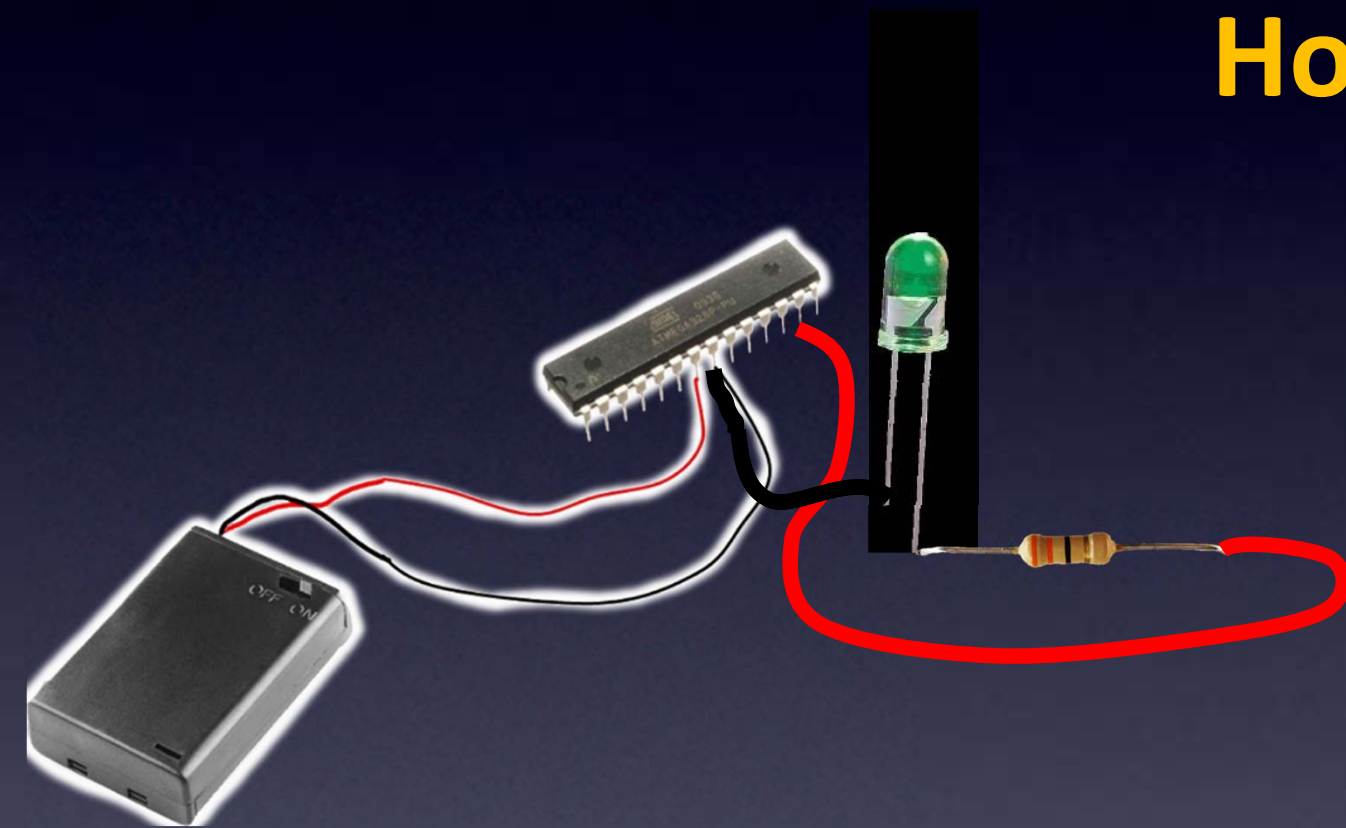

Turning an LED on and off

Hello World

Everything You Need to Know About Electronics

Programs on microcontrollers are called **“Firmware”**

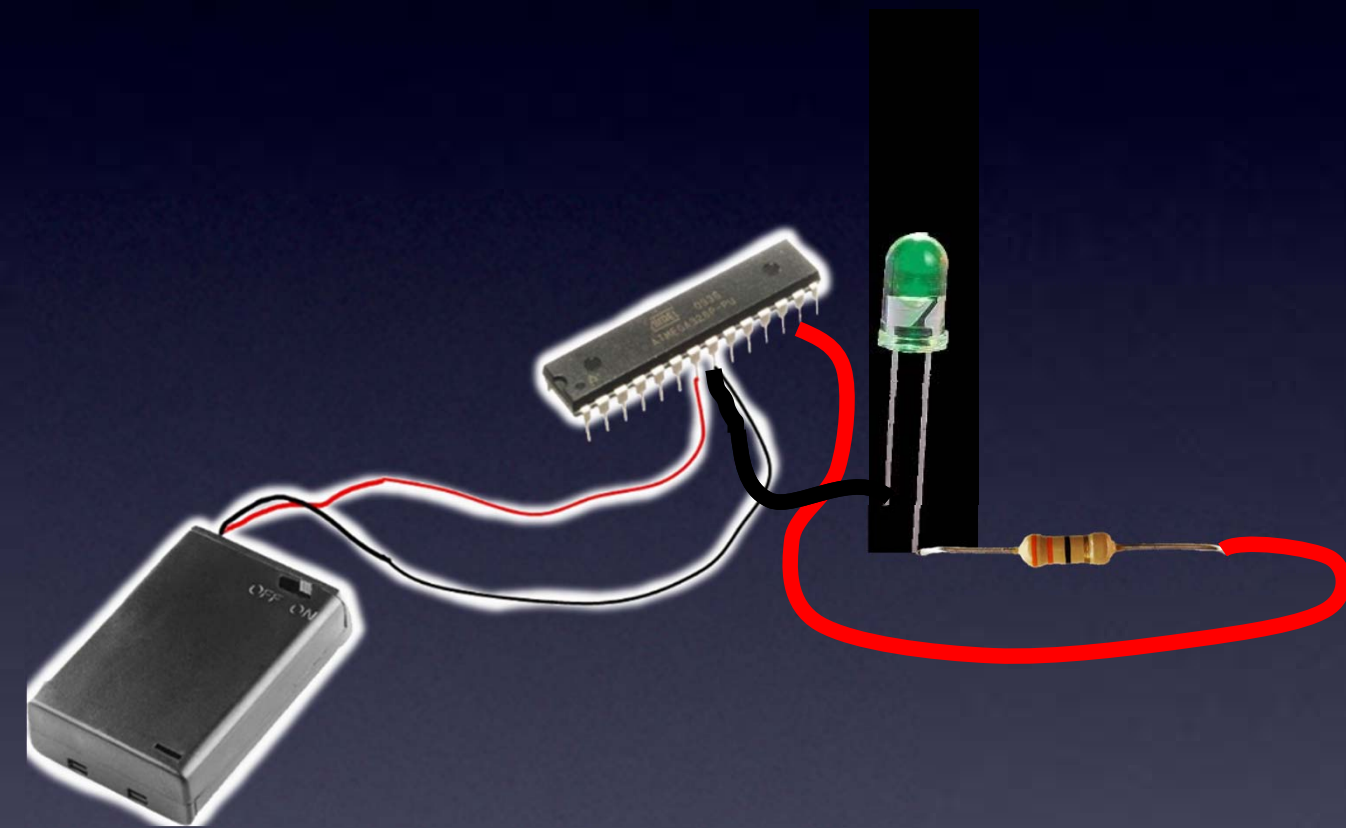

Turning an LED on and off

Hello World

Everything You Need to Know About Electronics

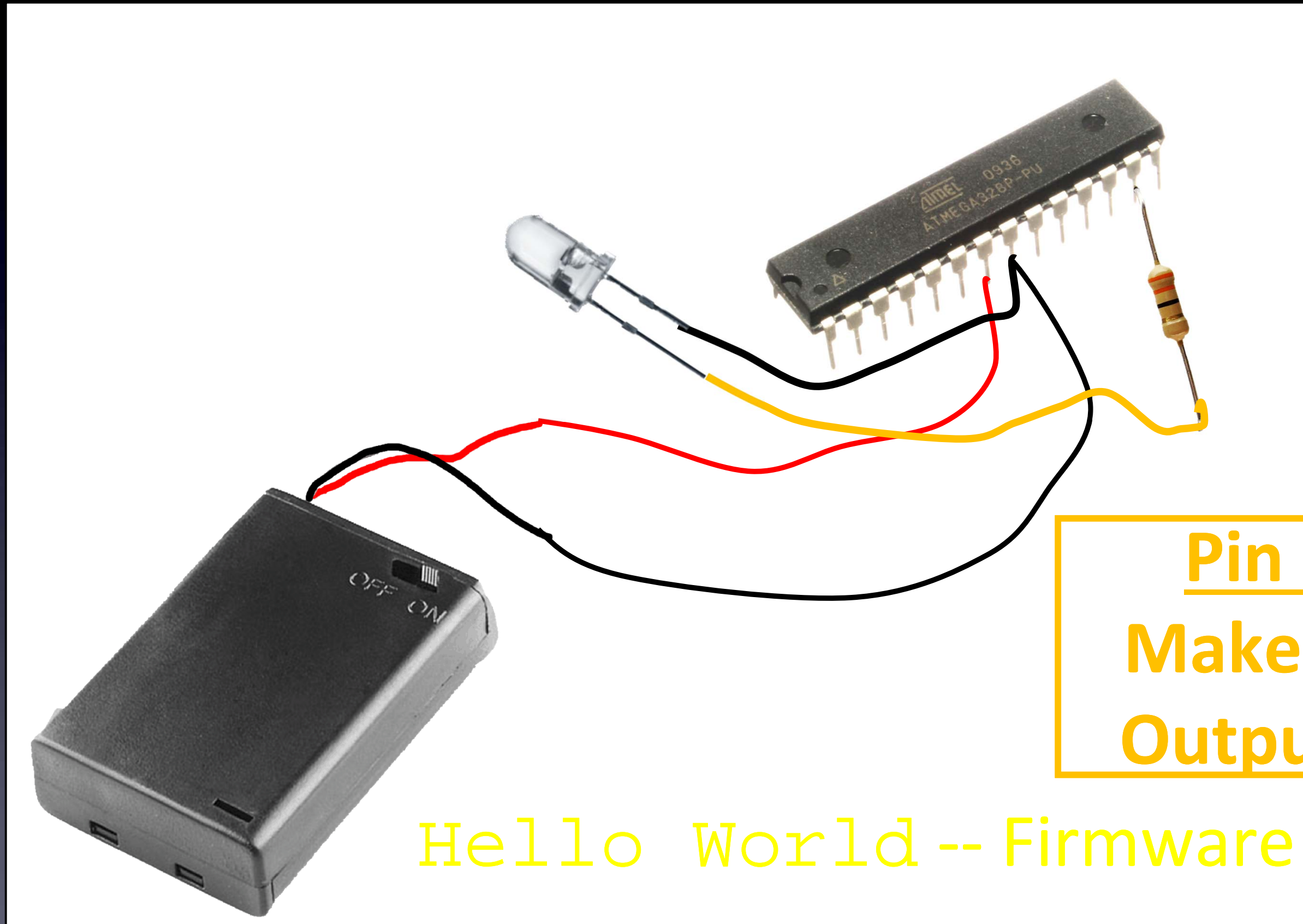

Pin 13:
Make it an
Output pin

Hello World -- Firmware

Microcontroller

Everything You Need to Know About Electronics

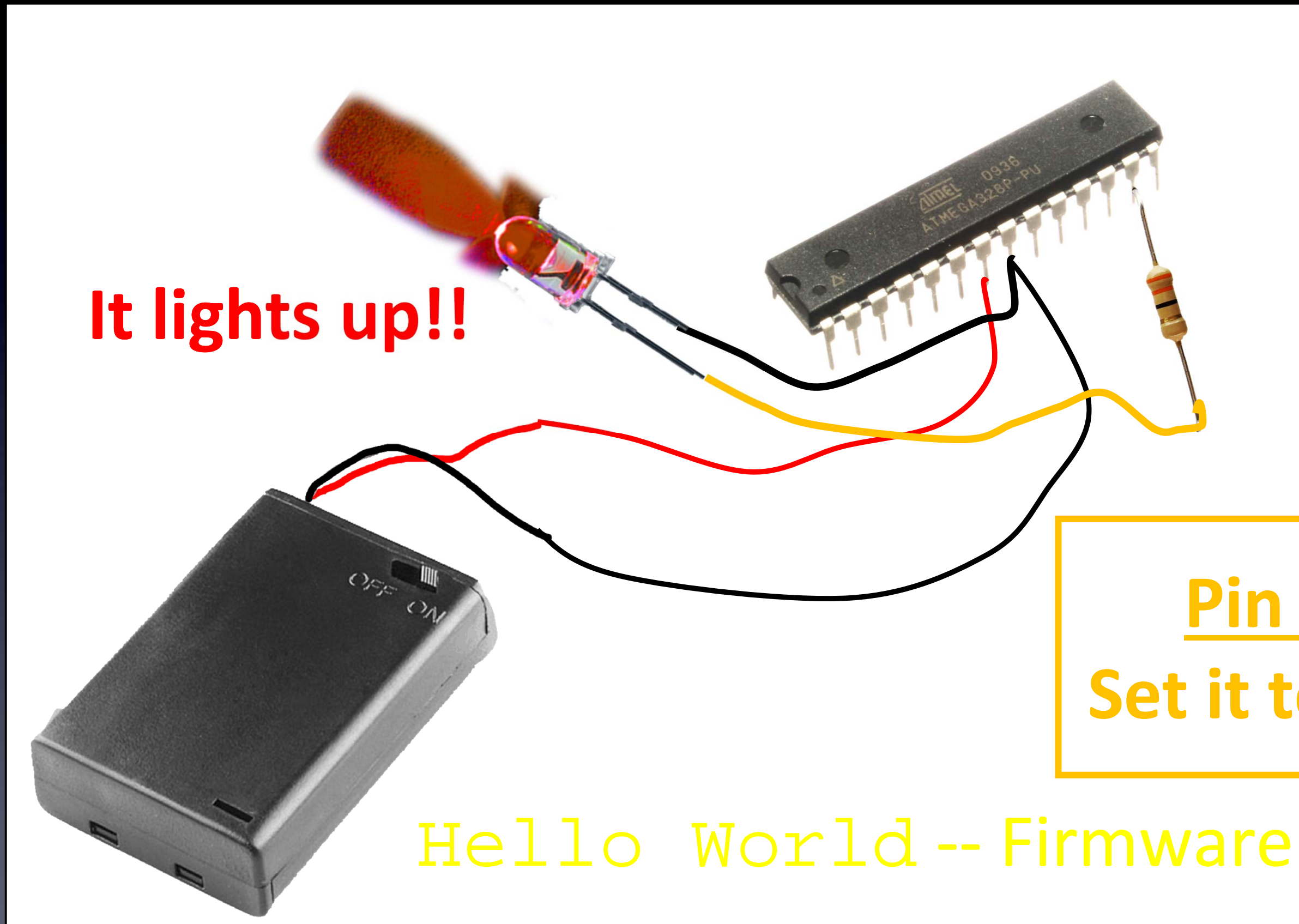

It lights up!!

Pin 13:
Set it to High

Hello World -- Firmware

Microcontroller

Everything You Need to Know About Electronics

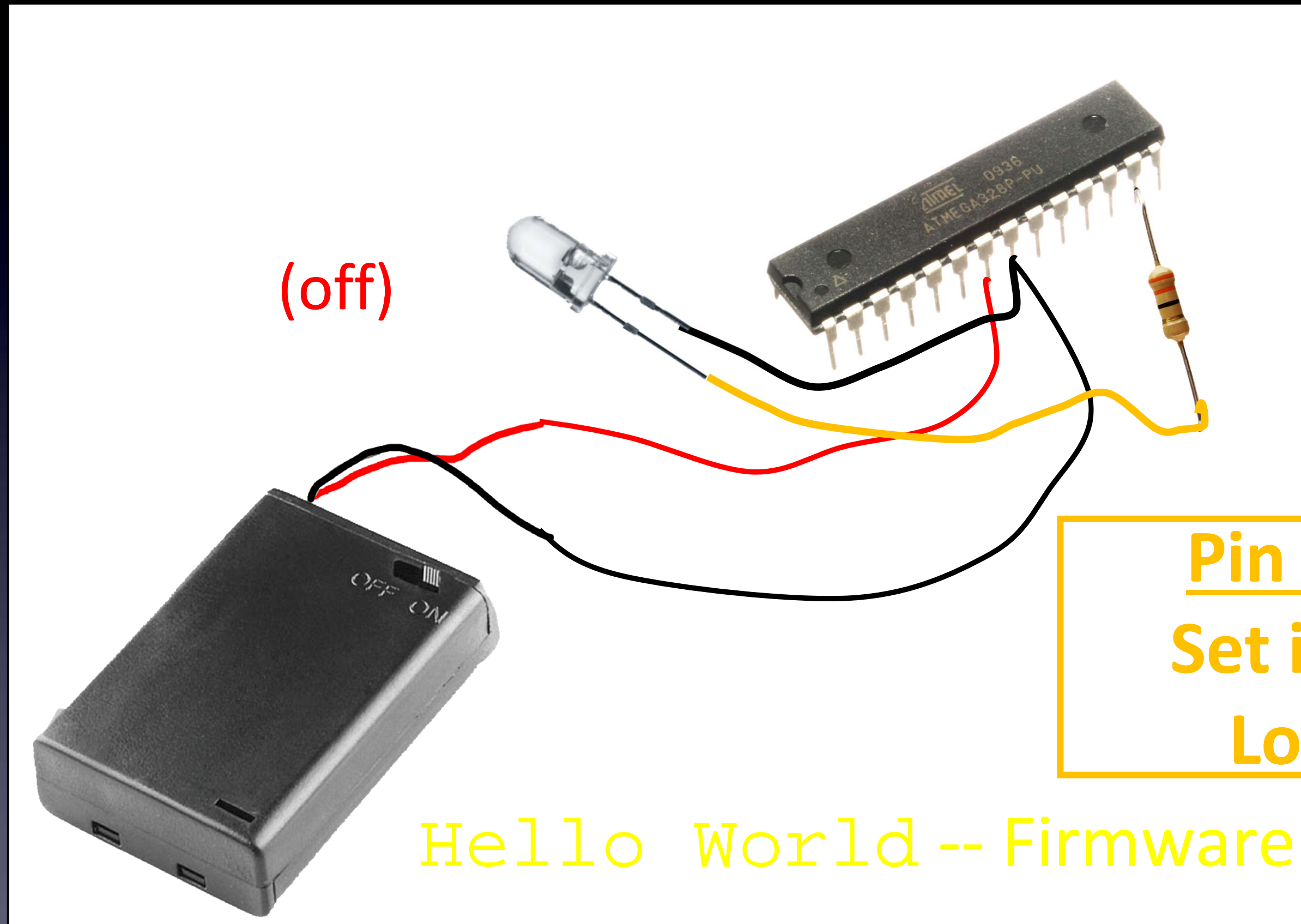

(off)

Pin 13:
Set it to
Low

Hello World -- Firmware

Microcontroller

Everything You Need to Know About Electronics



We now have
Hello World !

Microcontroller

Everything You Need to Know About Electronics

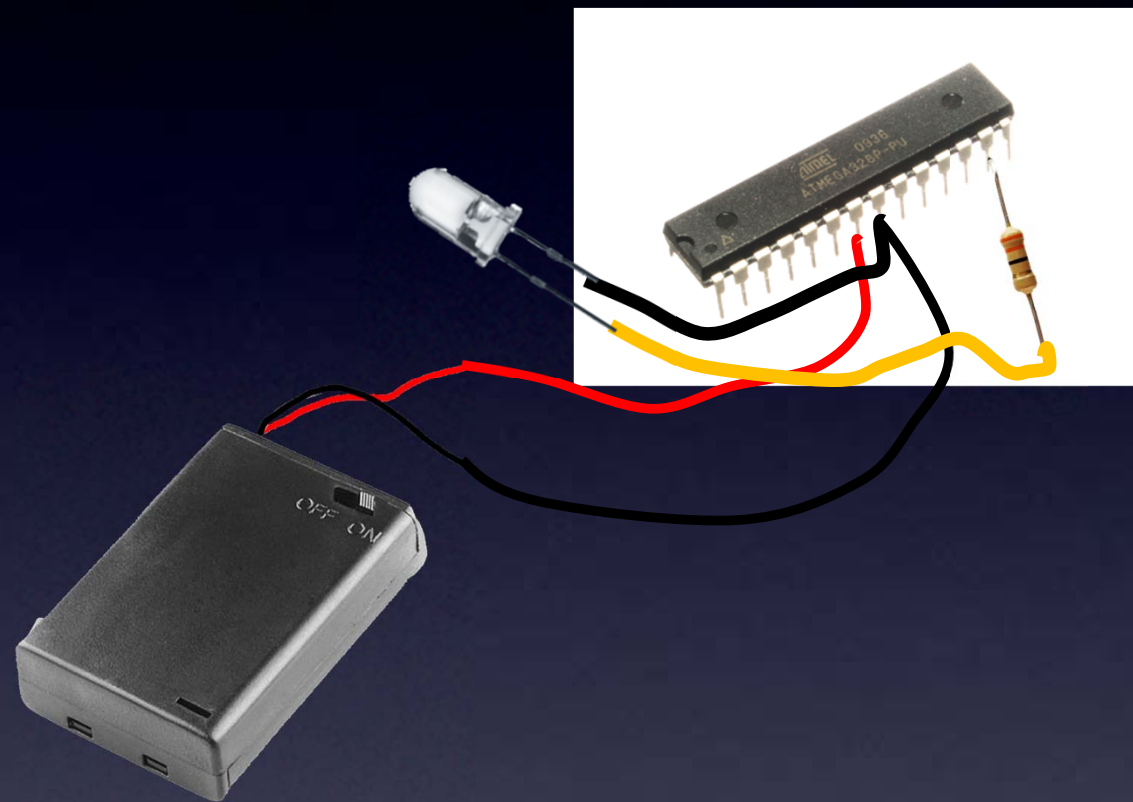

We now have
Hello World !

Except

We won't see it



Microcontroller

Everything You Need to Know About Electronics

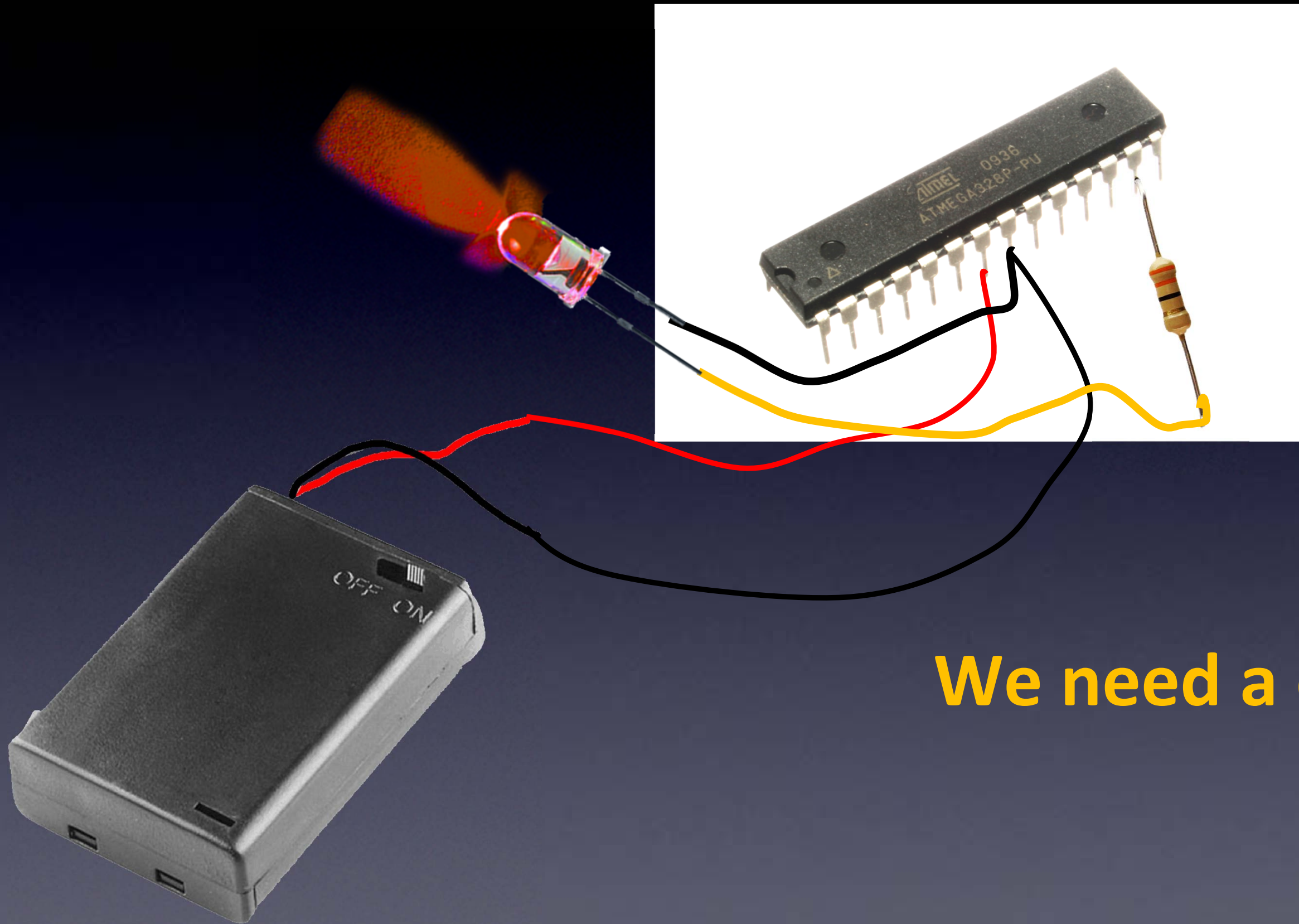

We need a delay

Microcontrollers – they go really fast!

Everything You Need to Know About Electronics

Hardware

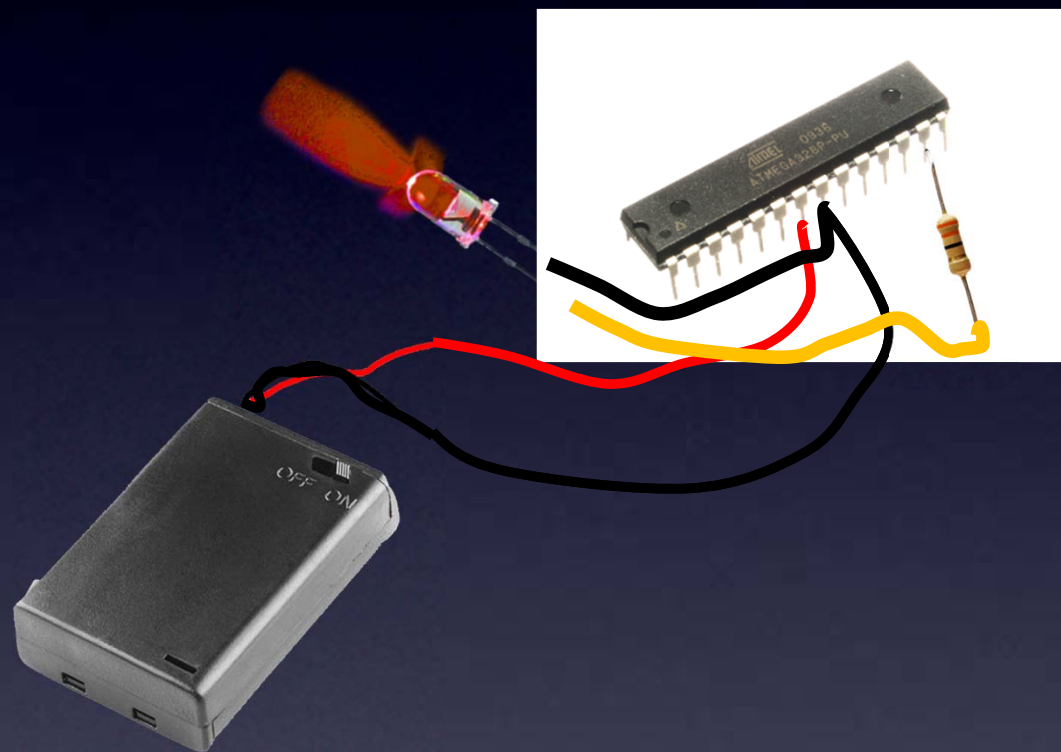

Firmware

- pin 13 is Output pin
- set pin 13 High
- delay
- set pin 13 Low

Hello World – for real now!

Microcontroller – Firmware

Everything You Need to Know About Electronics

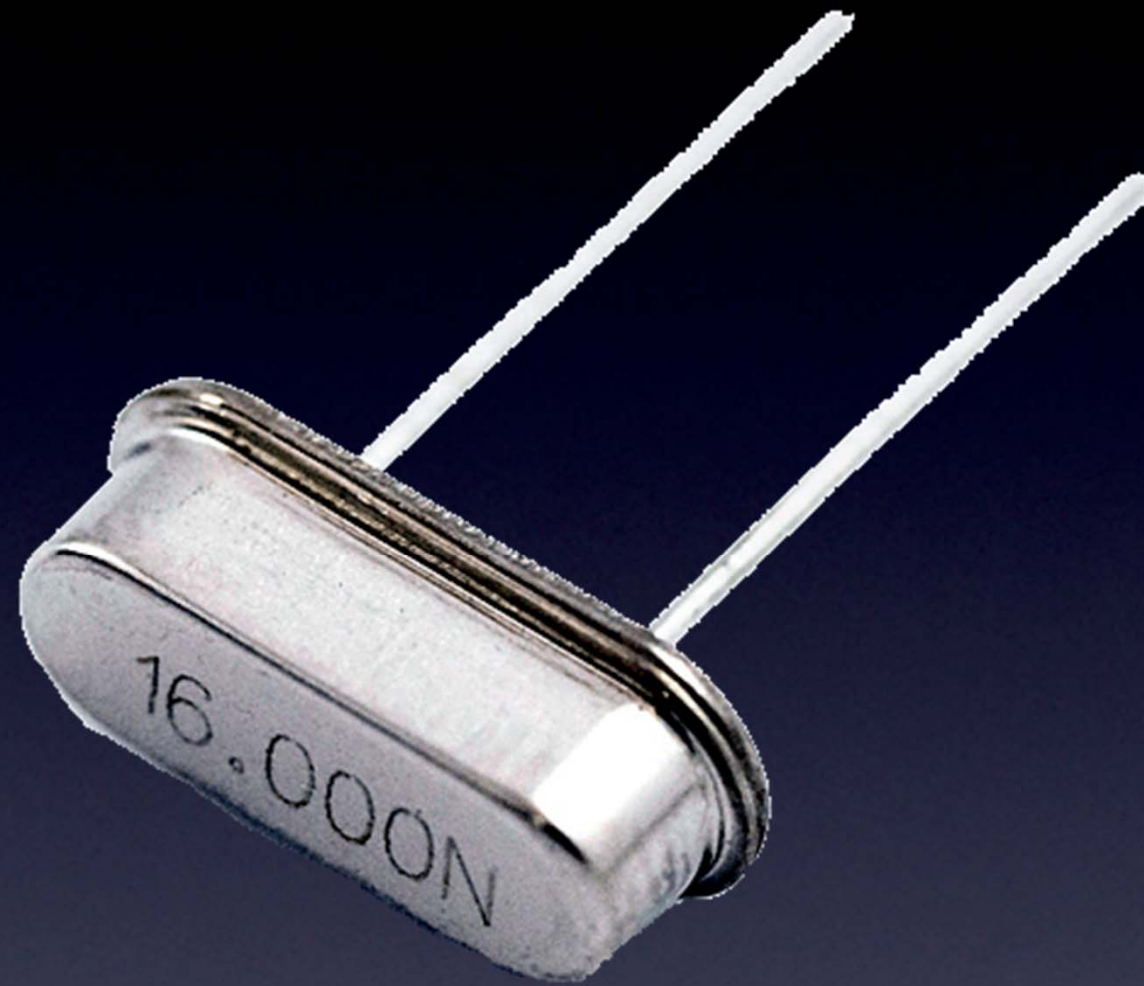

A precision cut piece of quartz crystal

For precise timing

Crystal

Everything You Need to Know About Electronics

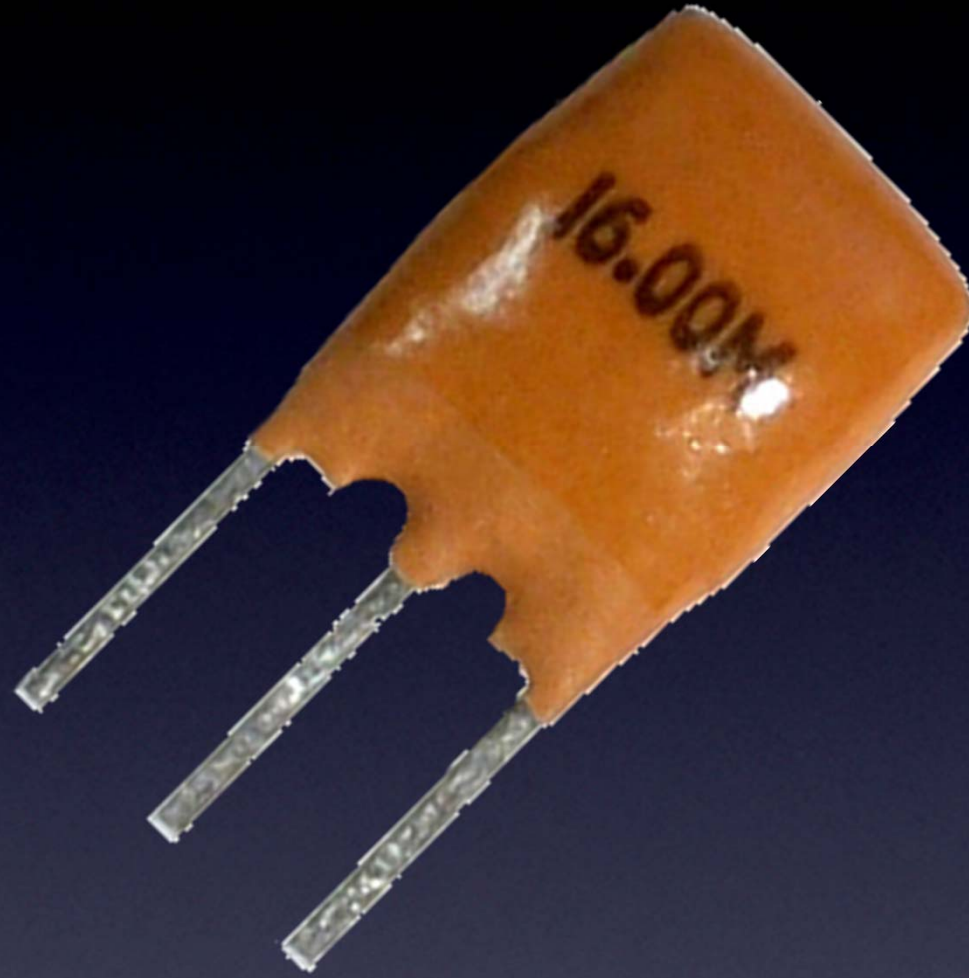

A bunch of resistors and capacitors

For precise timing (but less than a crystal)

Ceramic Resonator

Everything You Need to Know About Electronics

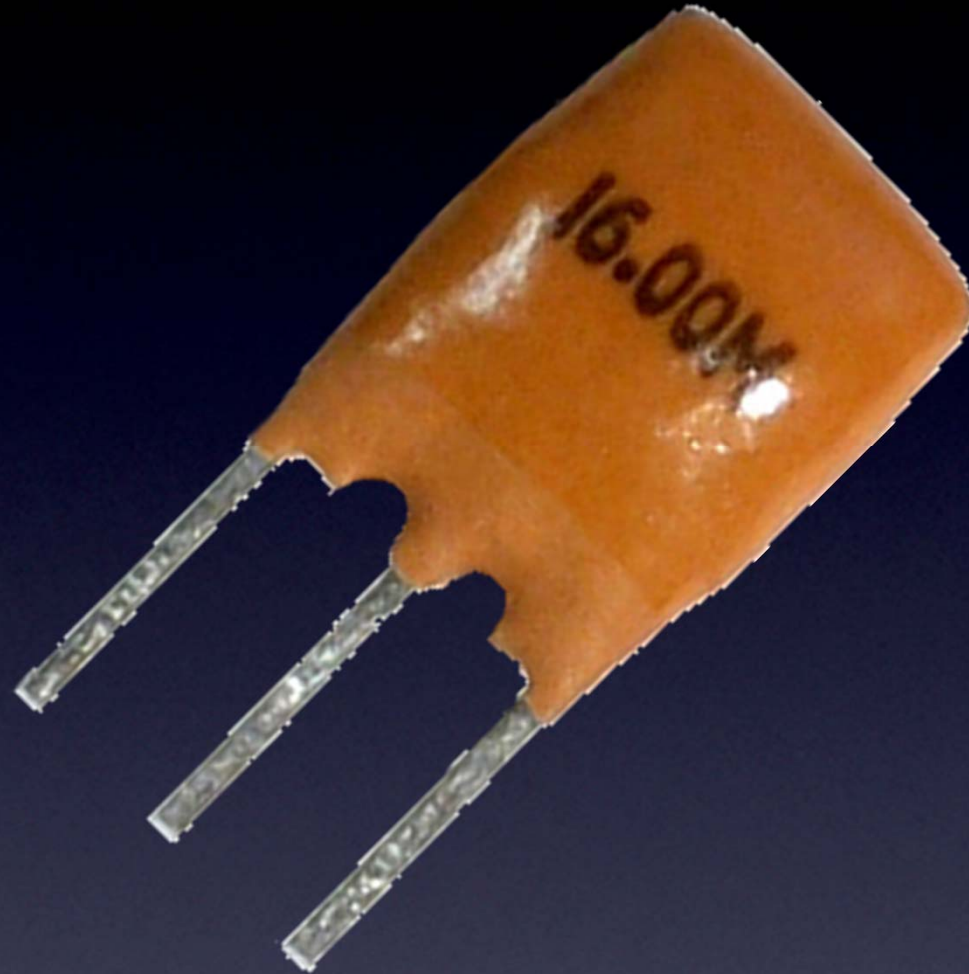

Frequency, measured in **Hertz**

For precise timing (but less than a crystal)

Ceramic Resonator / **Hertz**

Everything You Need to Know About Electronics

Hardware

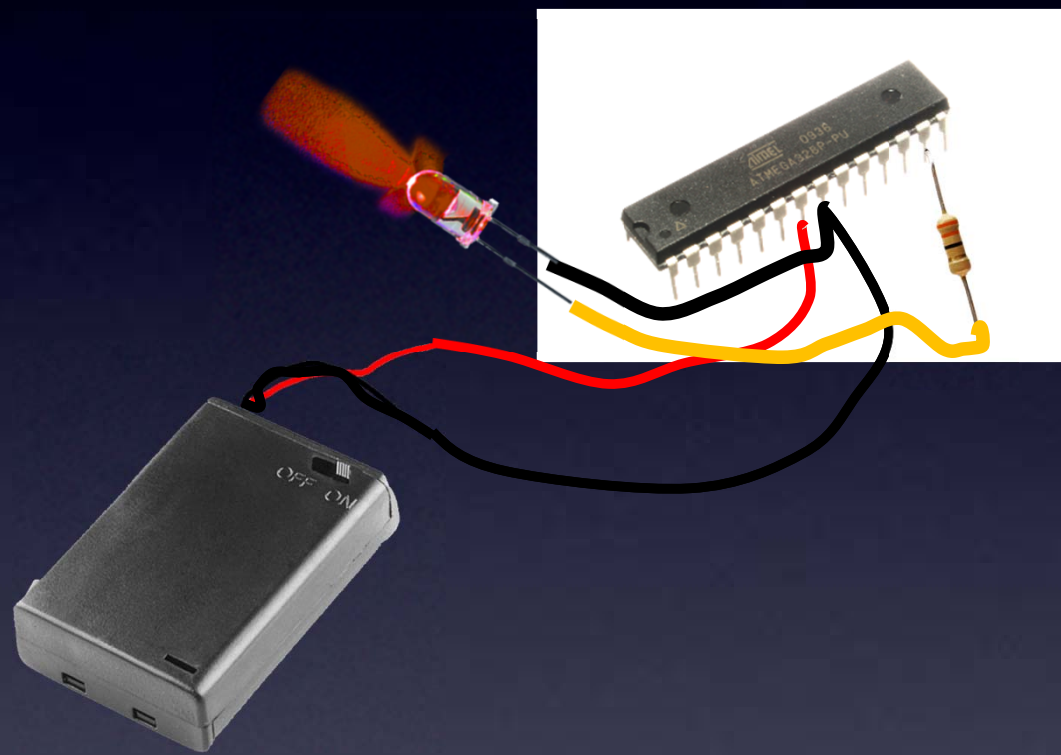

Firmware

- pin 13 is Output pin
- set pin 13 High
- delay
- set pin 13 Low

Let's hack Hello World!

Microcontroller

Everything You Need to Know About Electronics

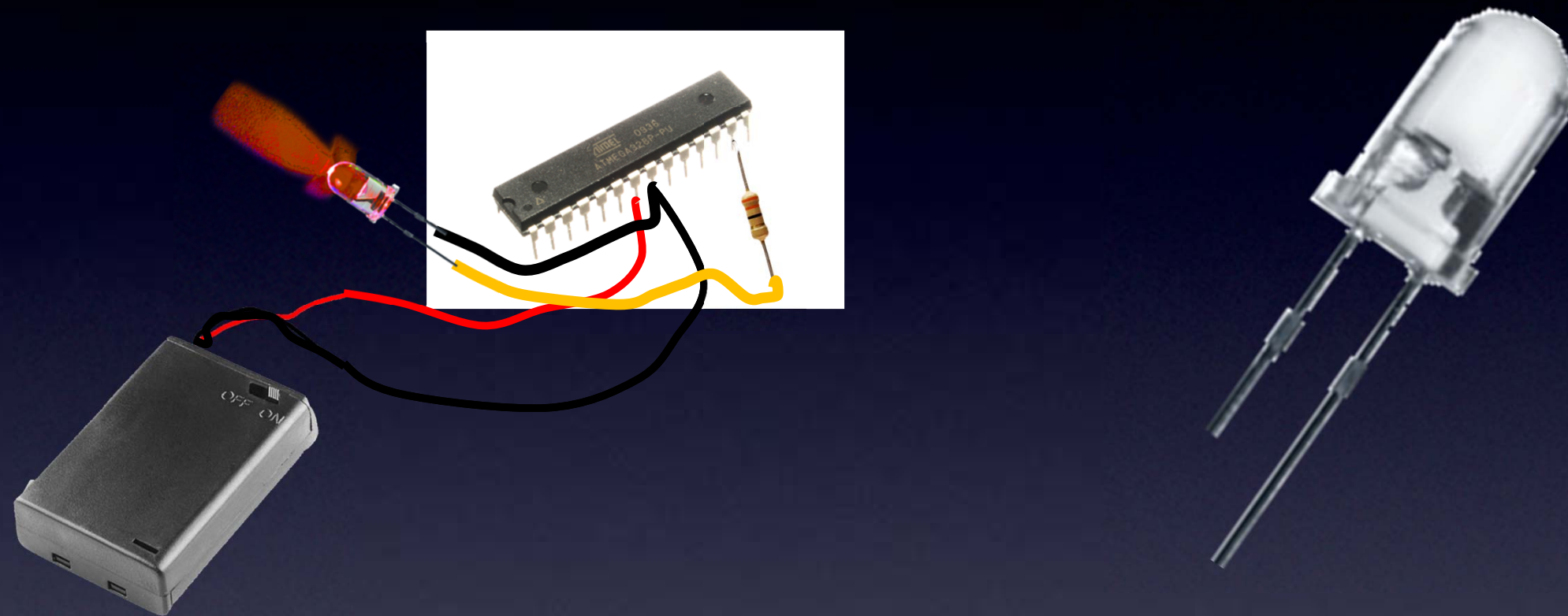

Add an IR LED to another pin

IR "OFF" codes

Microcontroller

Everything You Need to Know About Electronics

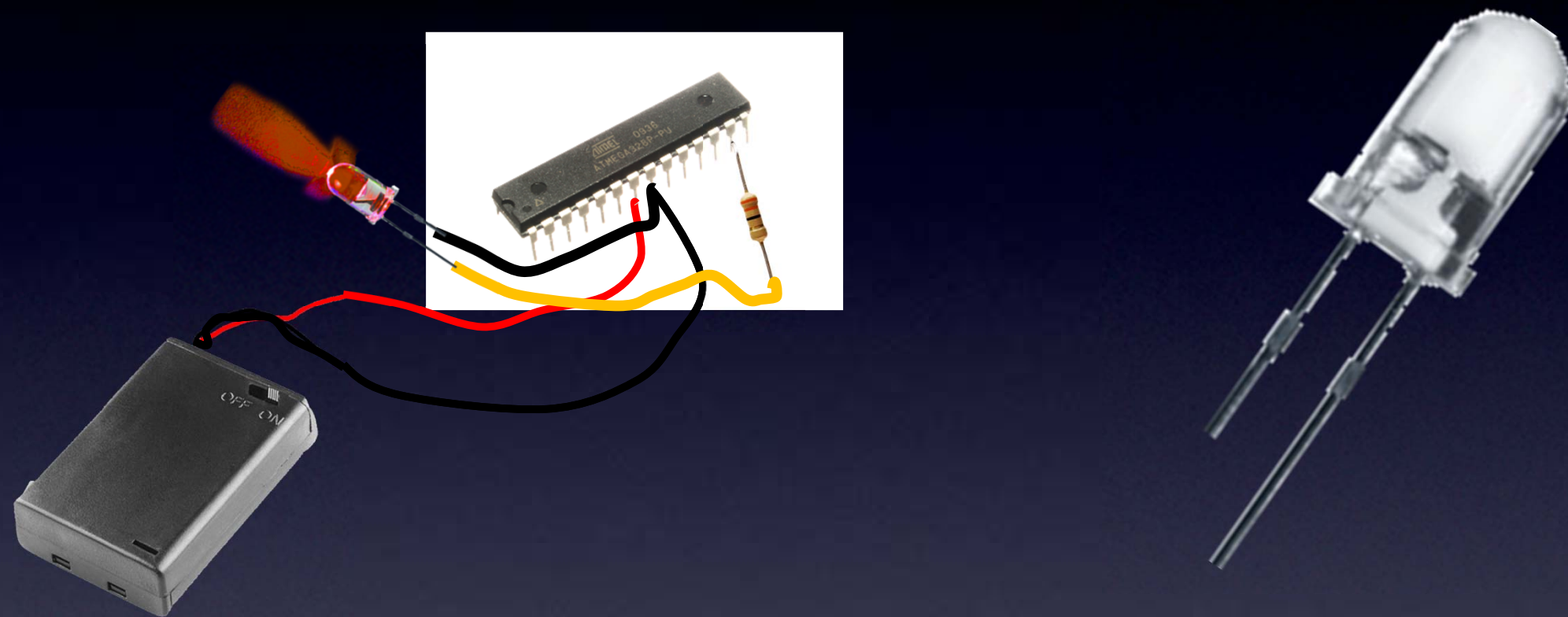

Add an IR LED to another pin (say, pin3)

IR "OFF" codes

Microcontroller

Everything You Need to Know About Electronics

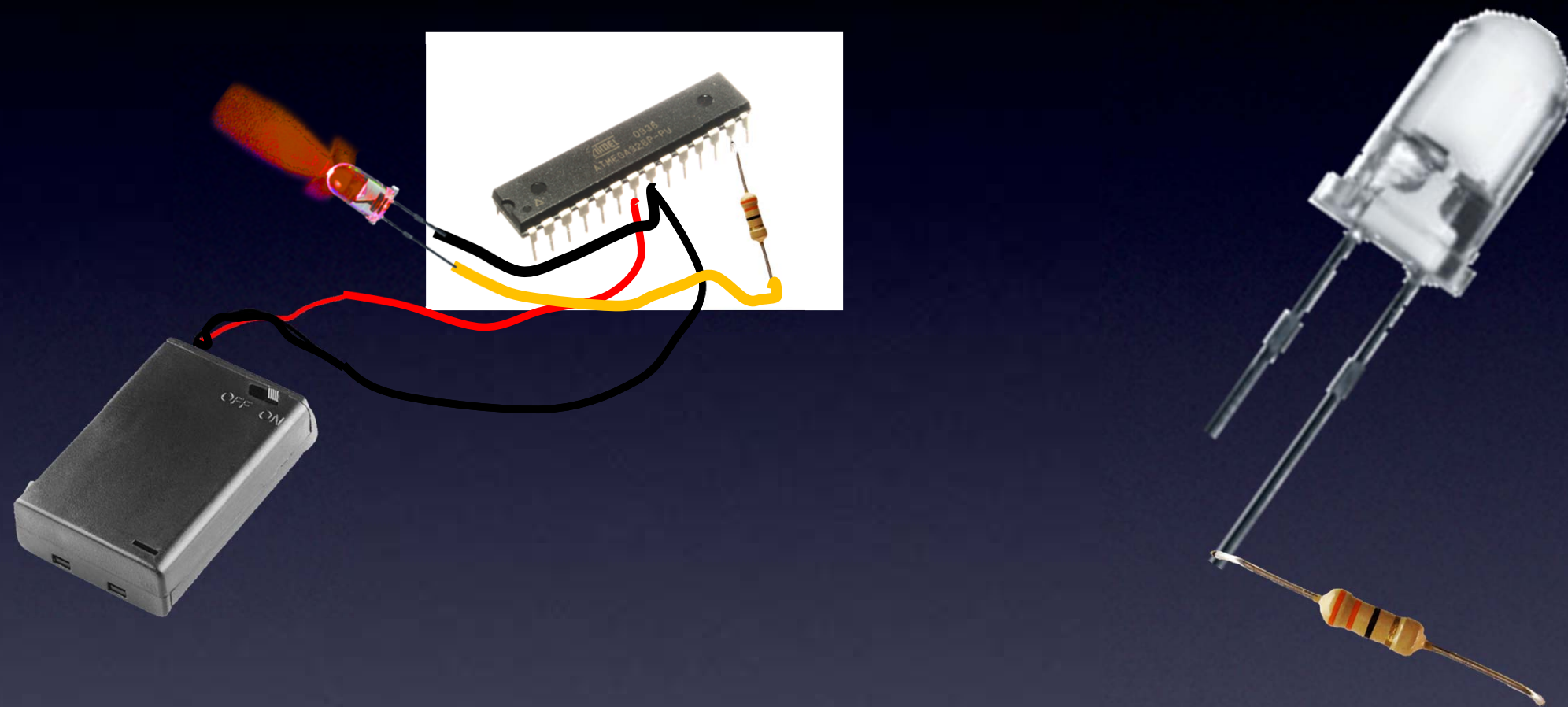

Add an IR LED to another pin (say, pin3)
and a resistor so no magic smoke goes away

IR "OFF" codes

Microcontroller

Everything You Need to Know About Electronics

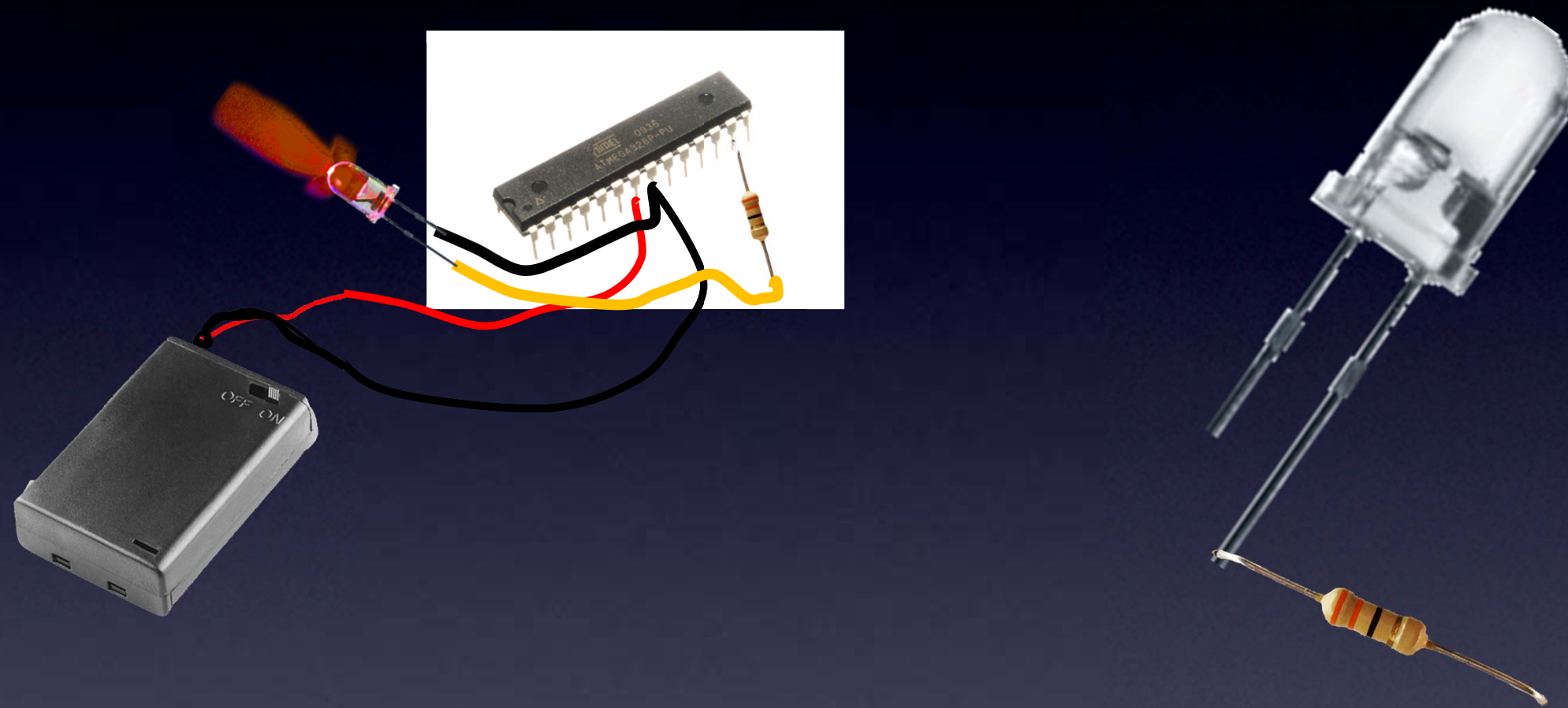

But, *When?*

IR "OFF" codes

Microcontroller

Everything You Need to Know About Electronics

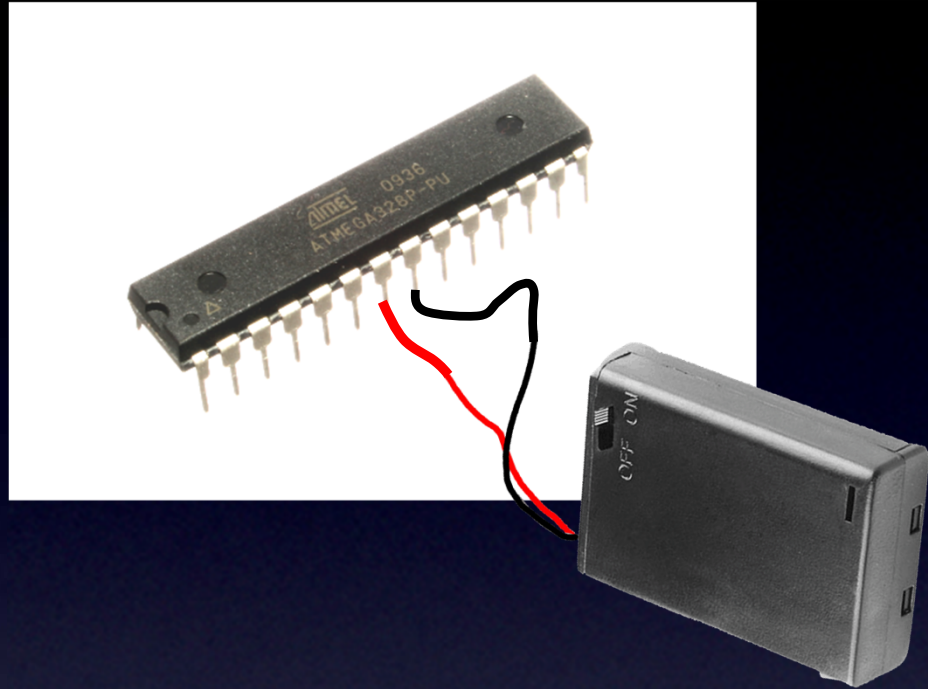

Let's add an Input pin!

and

We can add a Start button

Microcontroller

Everything You Need to Know About Electronics

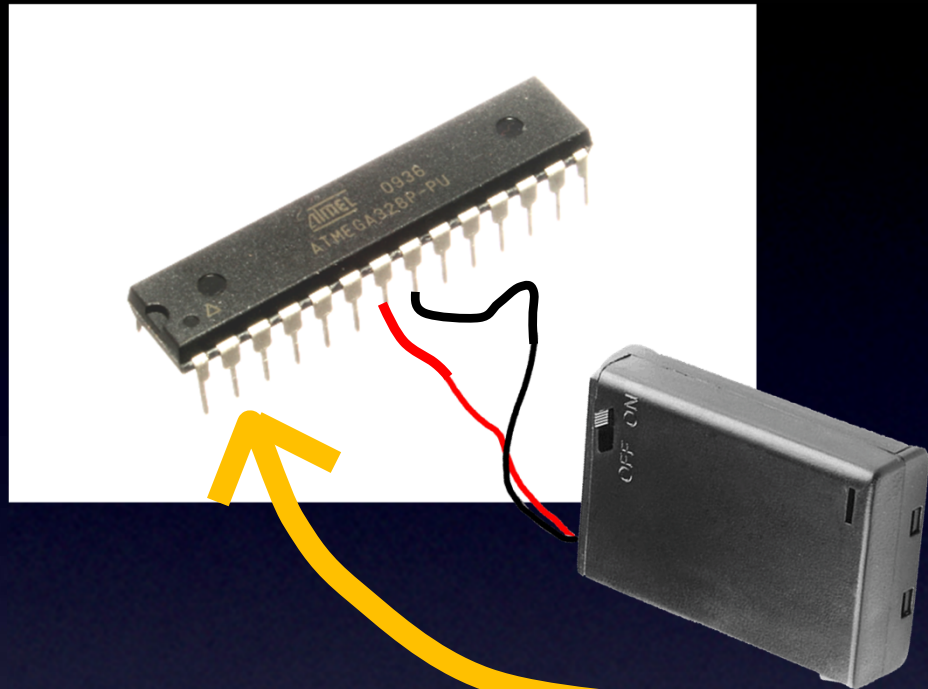

How do we make a pin an Input pin?

We tell it to be one – with our program.

Any pin can be an Input pin (like, pin 2).

Microcontroller – Input pins

Everything You Need to Know About Electronics

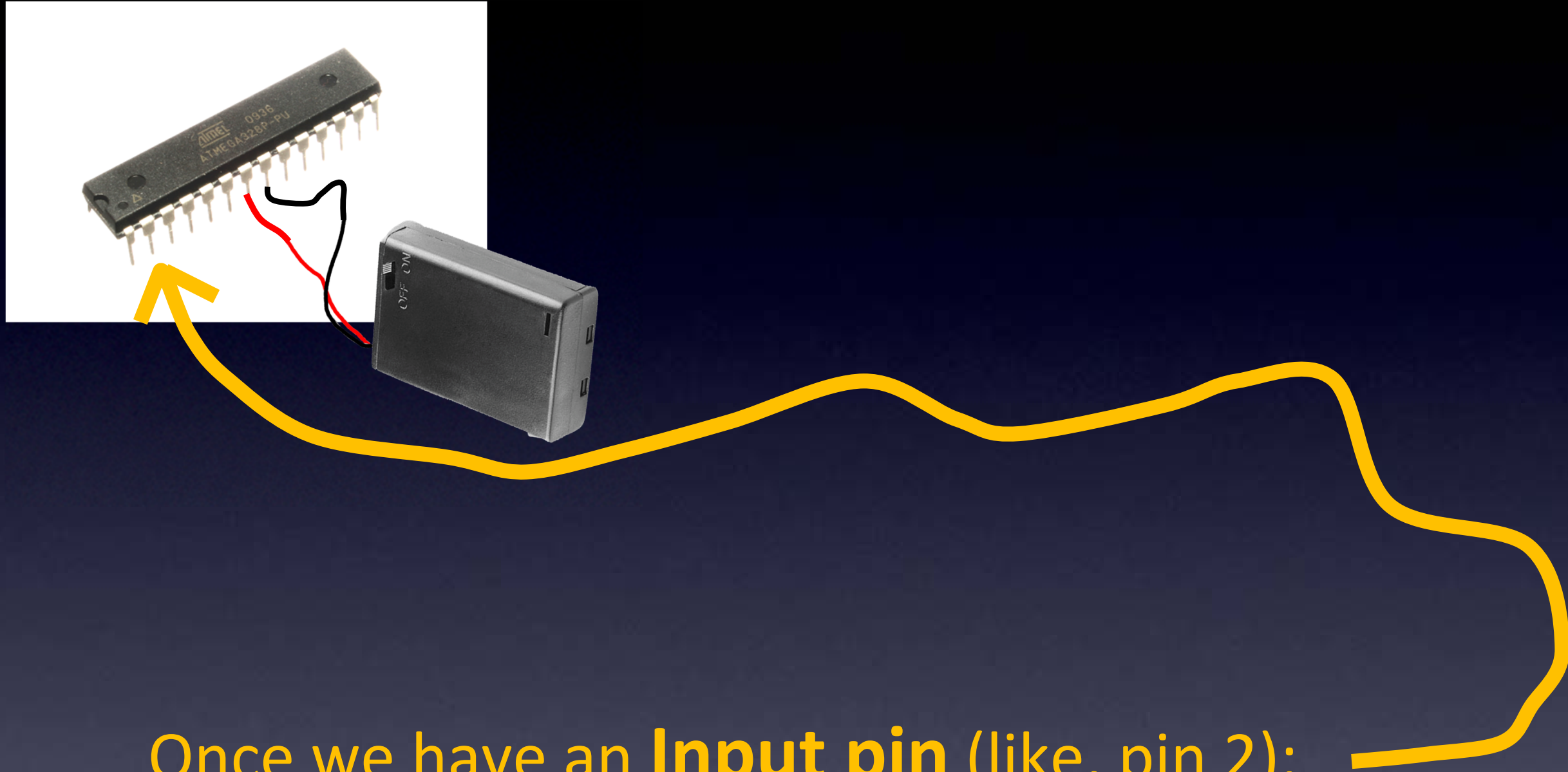

Once we have an **Input pin** (like, pin 2):

only 2 choices – is the Input pin: **High** or **Low** ?

Microcontroller – Input pins

Everything You Need to Know About Electronics

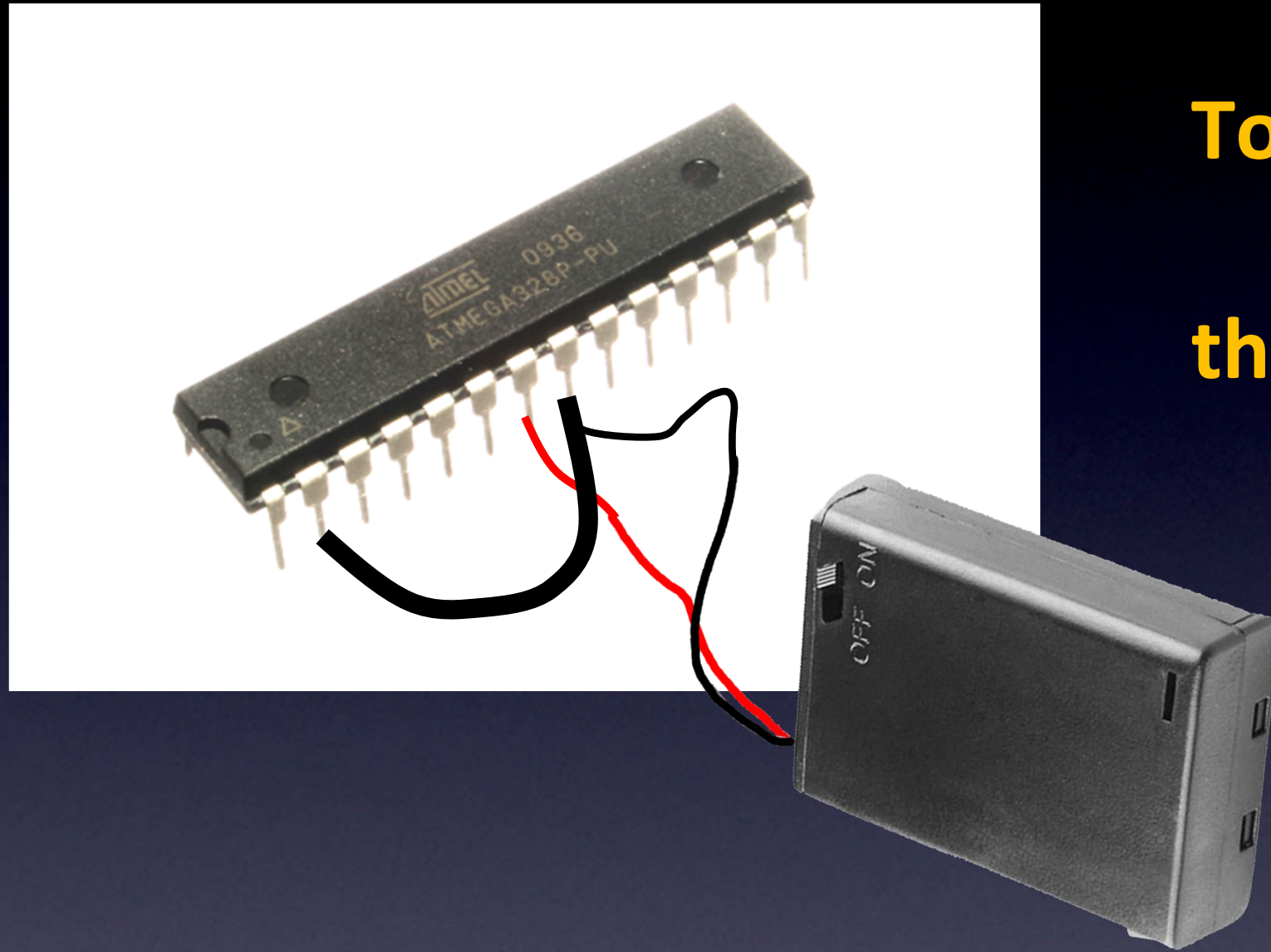

To make the Input pin Low, connect it to the Black wire of our power supply (Ground).

Low

Microcontroller – Input pins

Everything You Need to Know About Electronics

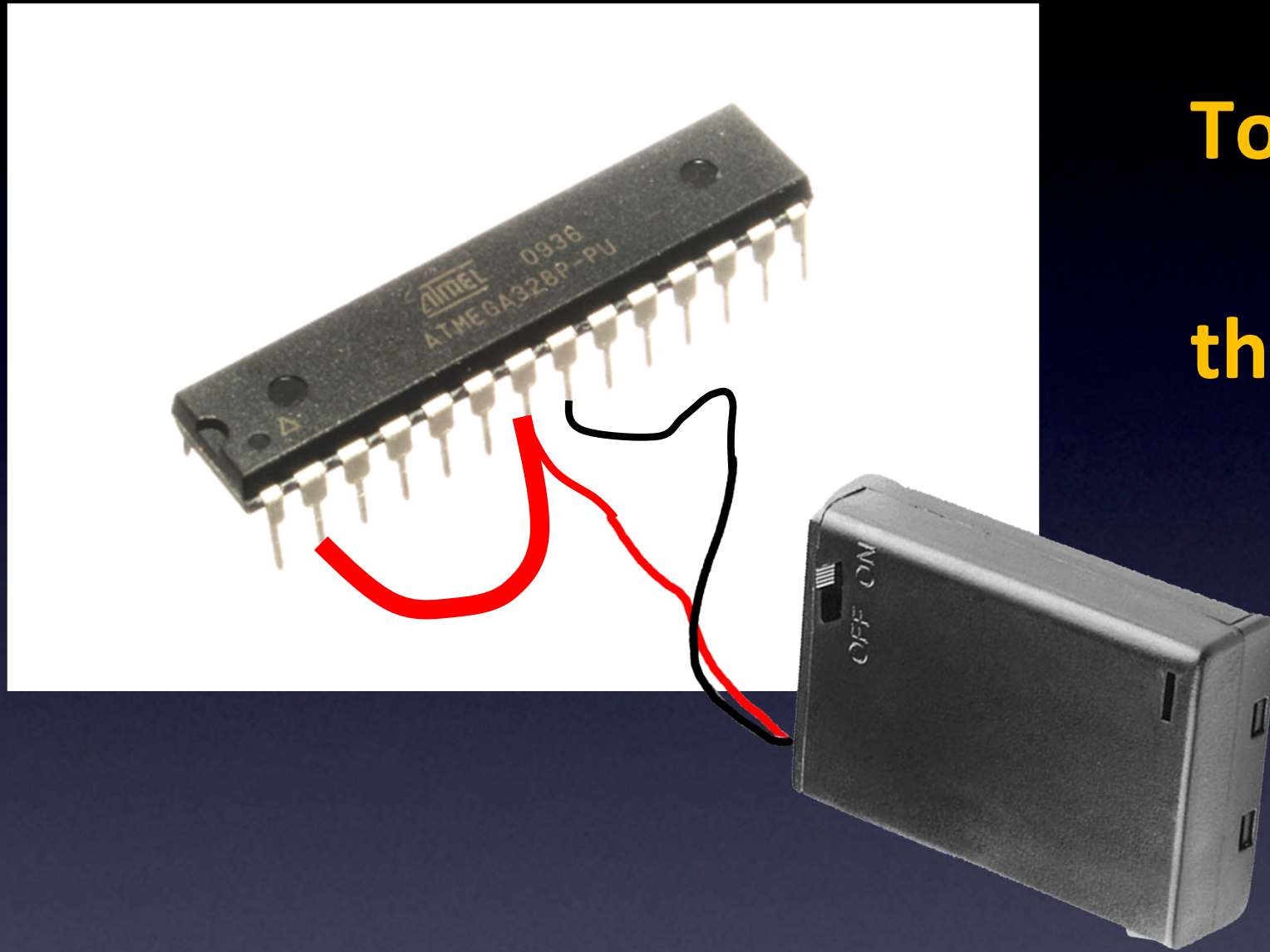

To make the Input pin High, connect it to the Red wire of our power supply (Vcc).

High

Microcontroller – Input pins

Everything You Need to Know About Electronics

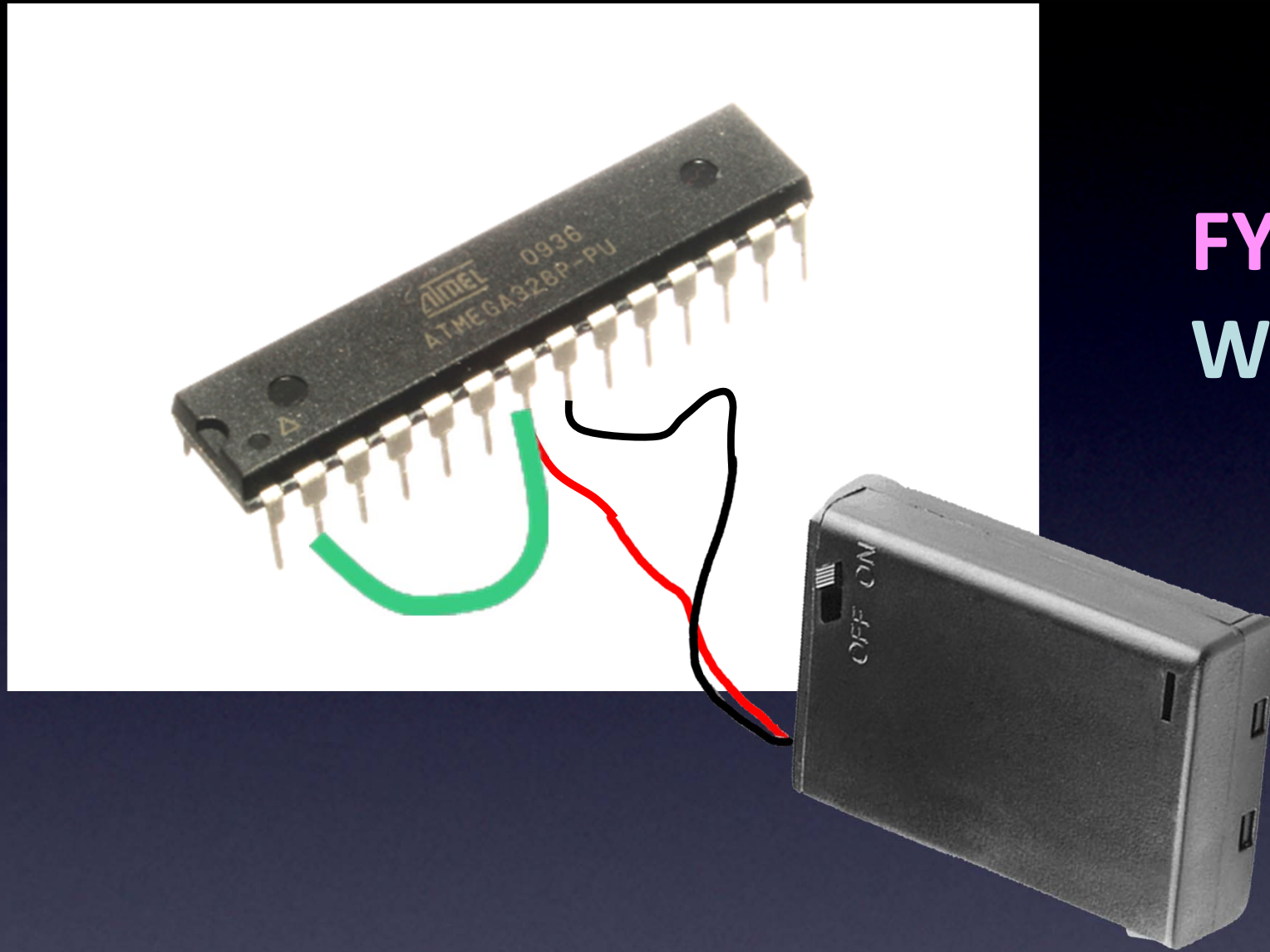

FYI:

Wire color does **not matter** !

(electrons don't care)

High

Microcontroller – Input pins

Everything You Need to Know About Electronics

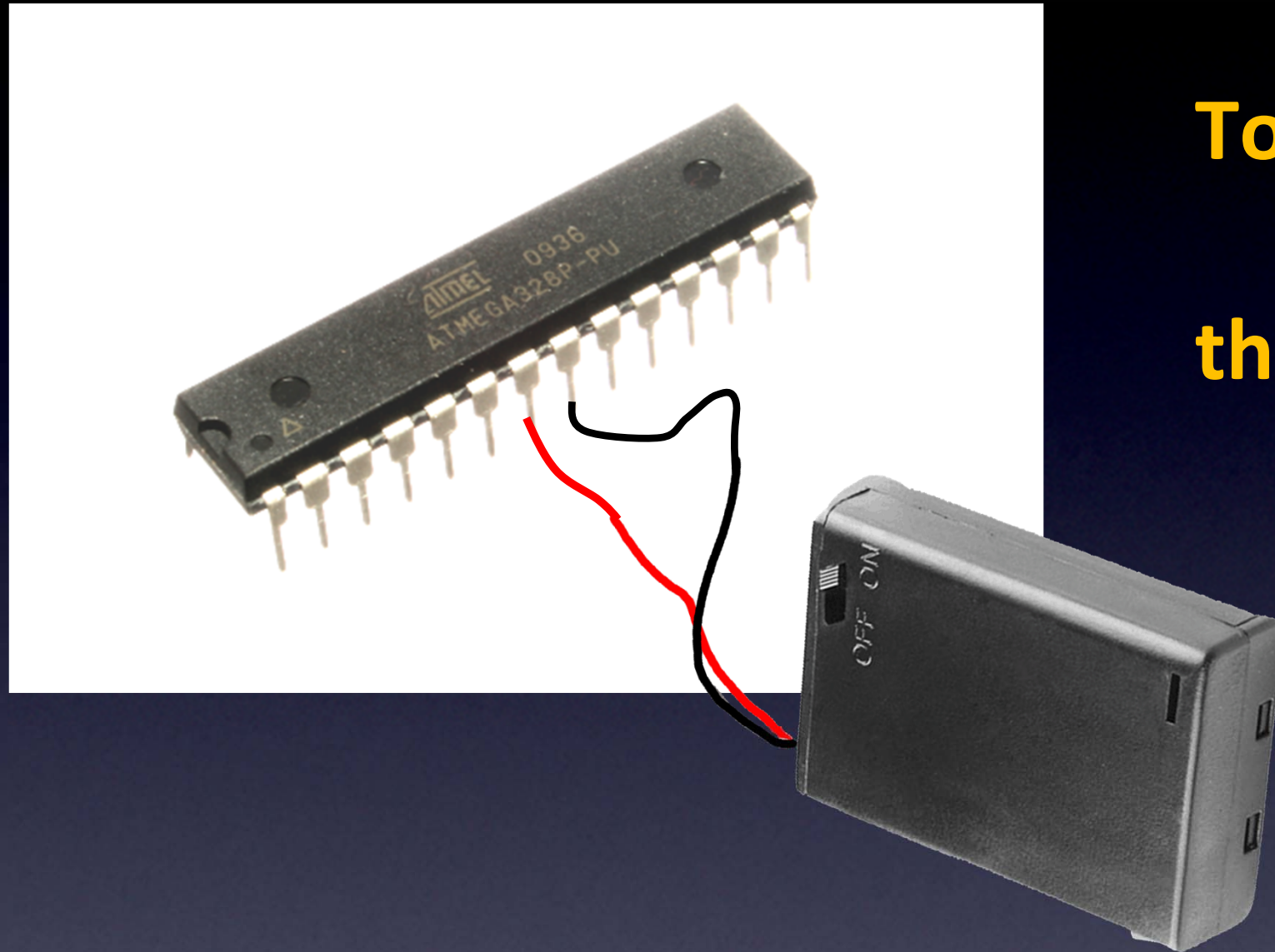

**To make the Input pin High,
connect it to
the Red wire of our power
supply (Vcc).**

OR:

just leave it blank
(built-in resistors on each pin)

High

Microcontroller – Input pins

Everything You Need to Know About Electronics

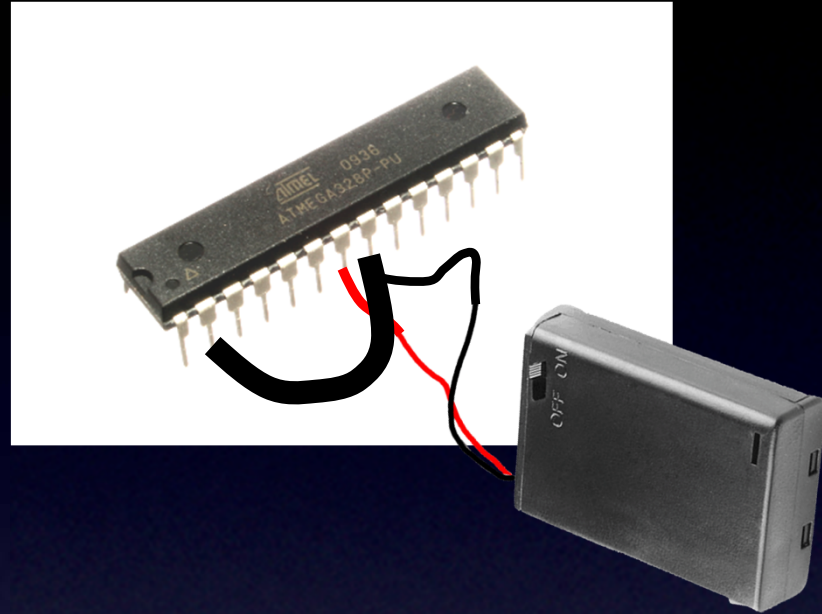

If firmware looks at
Pin 2 when it's like this,
it reports back:

Low

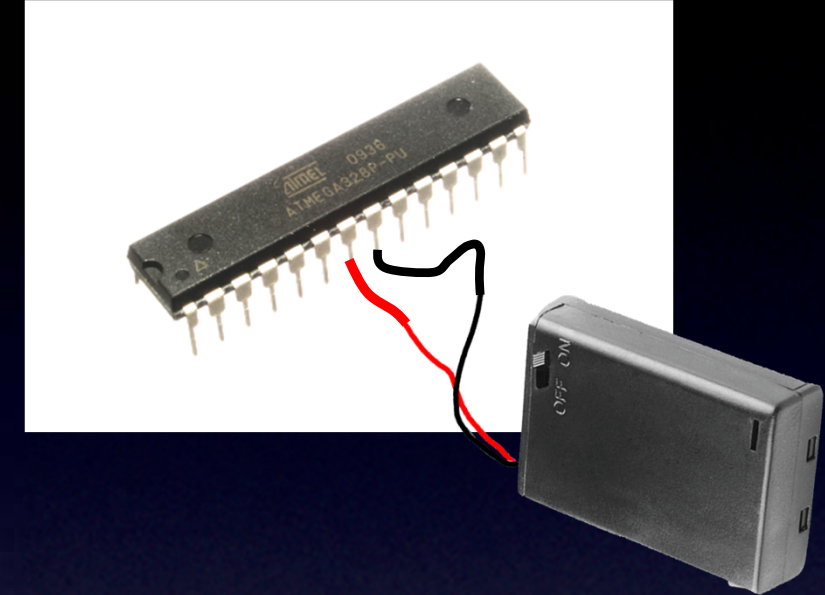

If firmware looks at
Pin 2 when it's like this,
it reports back:

High

Reading the Input pin

Microcontroller – Input pins

Everything You Need to Know About Electronics

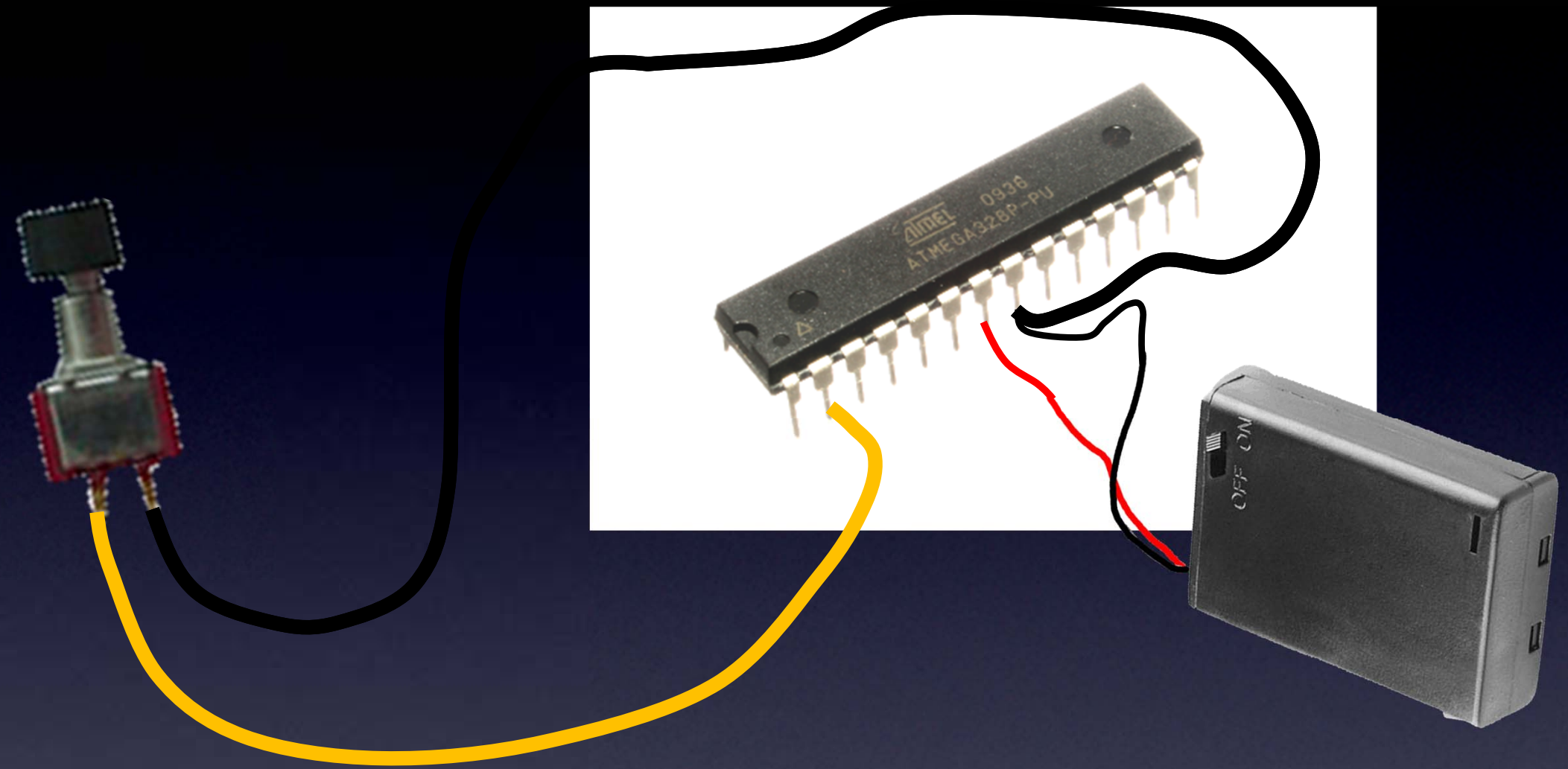

Reading the Input pin, with Switch

Microcontroller – Input pins

Everything You Need to Know About Electronics

If firmware
looks at Pin 2
when switch
NOT pushed,
it reports back:
High

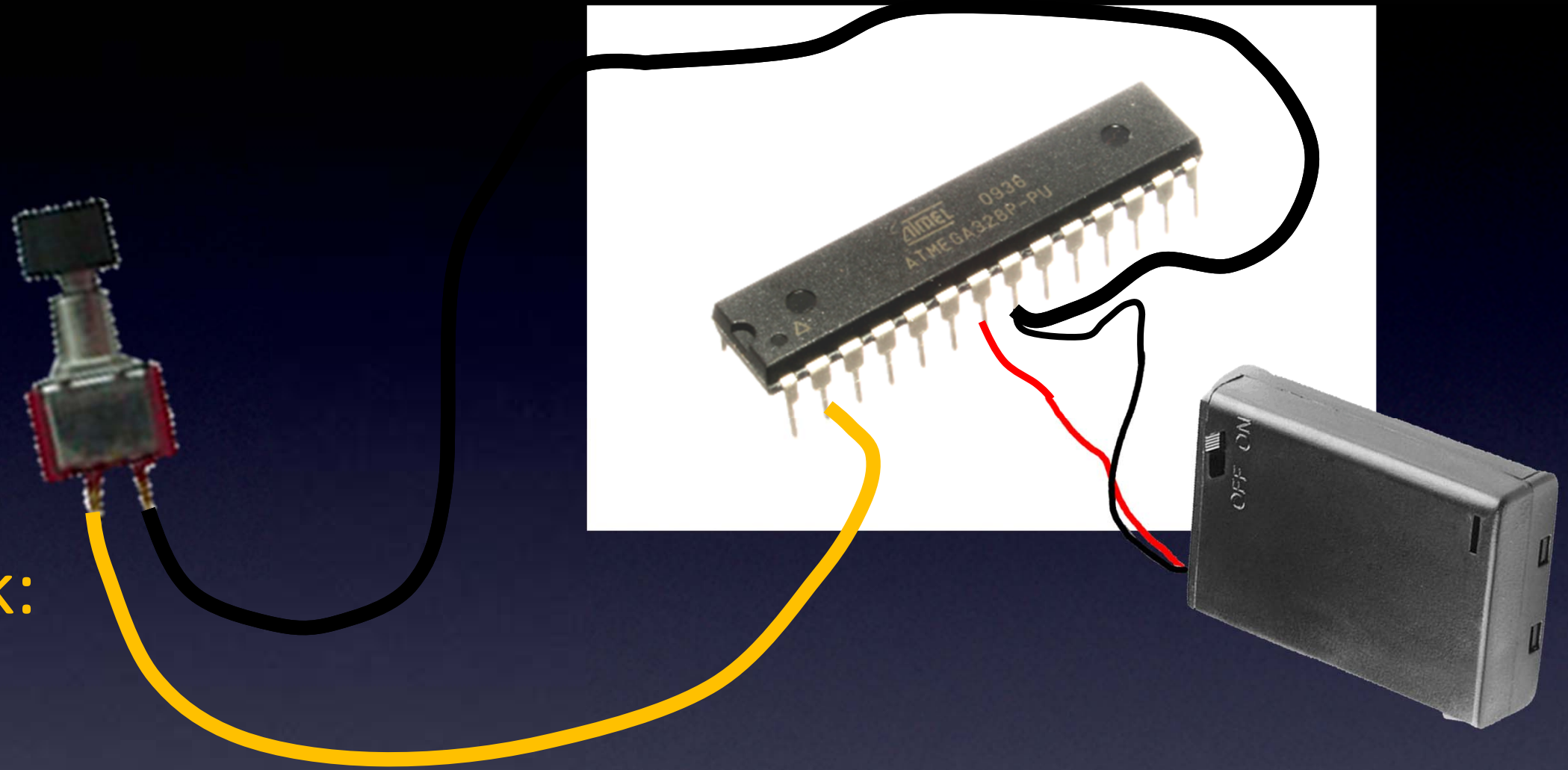

Reading the Input pin, with Switch

Microcontroller – Input pins

Everything You Need to Know About Electronics

If firmware looks at Pin 2 when switch pushed,
it reports back:
Low

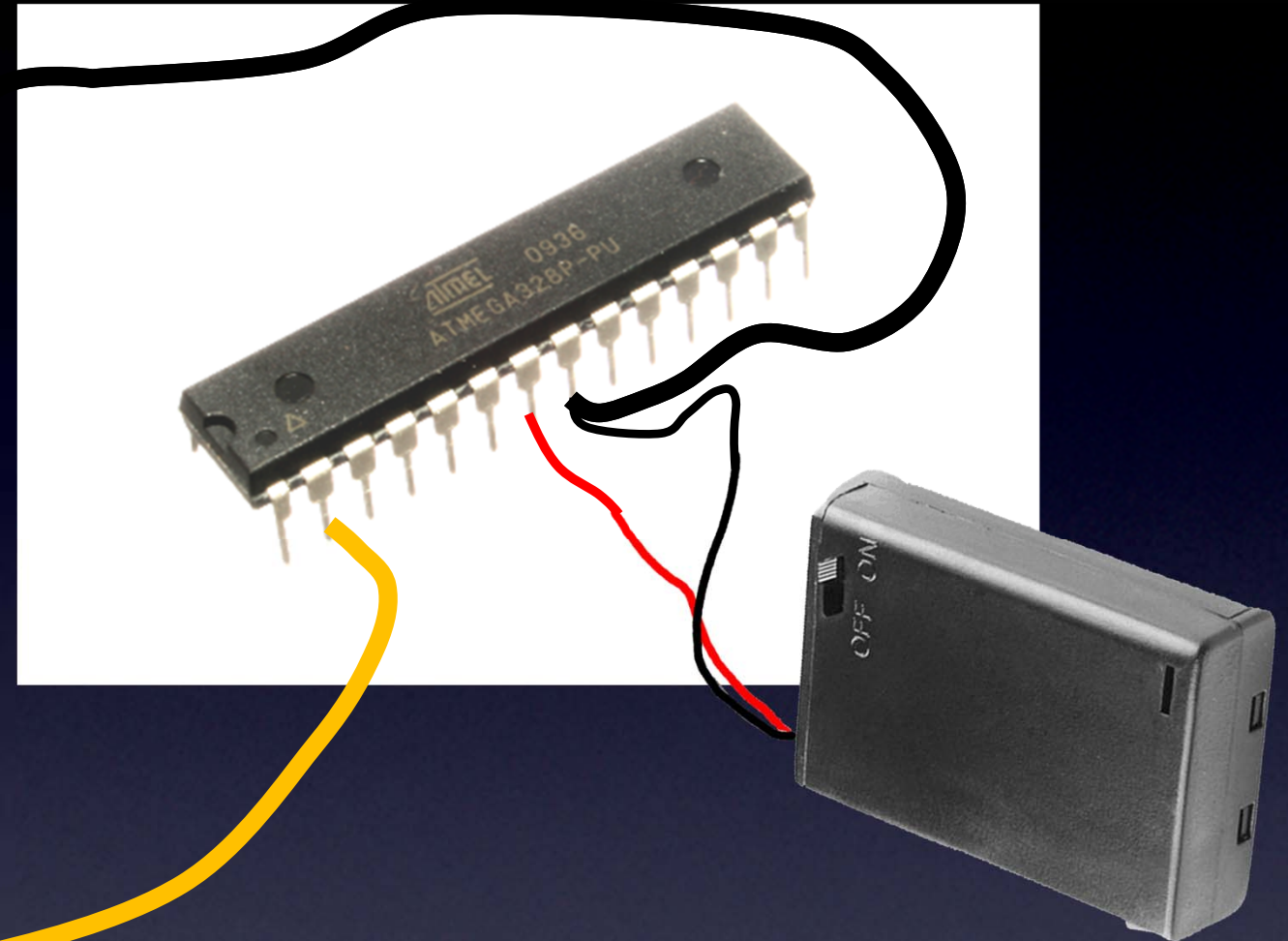
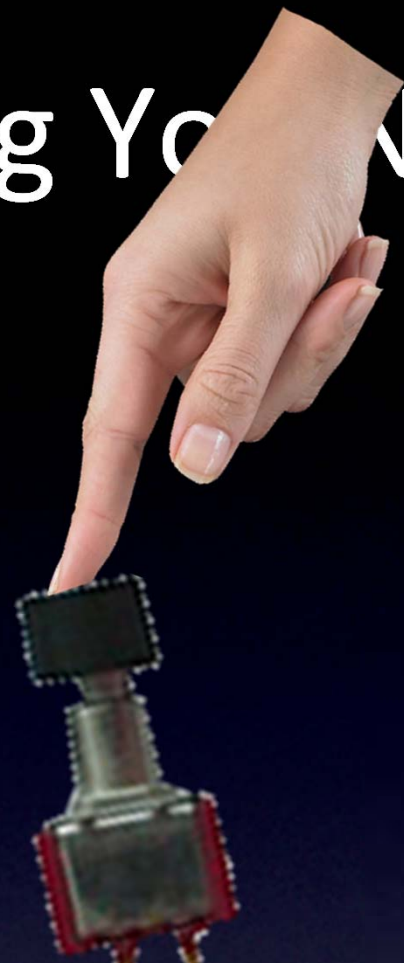

Reading the Input pin, with Switch

Microcontroller – Input pins

Everything You Need to Know About Electronics

If firmware
looks at Pin 2
when switch
NOT pushed,
it reports back:
High

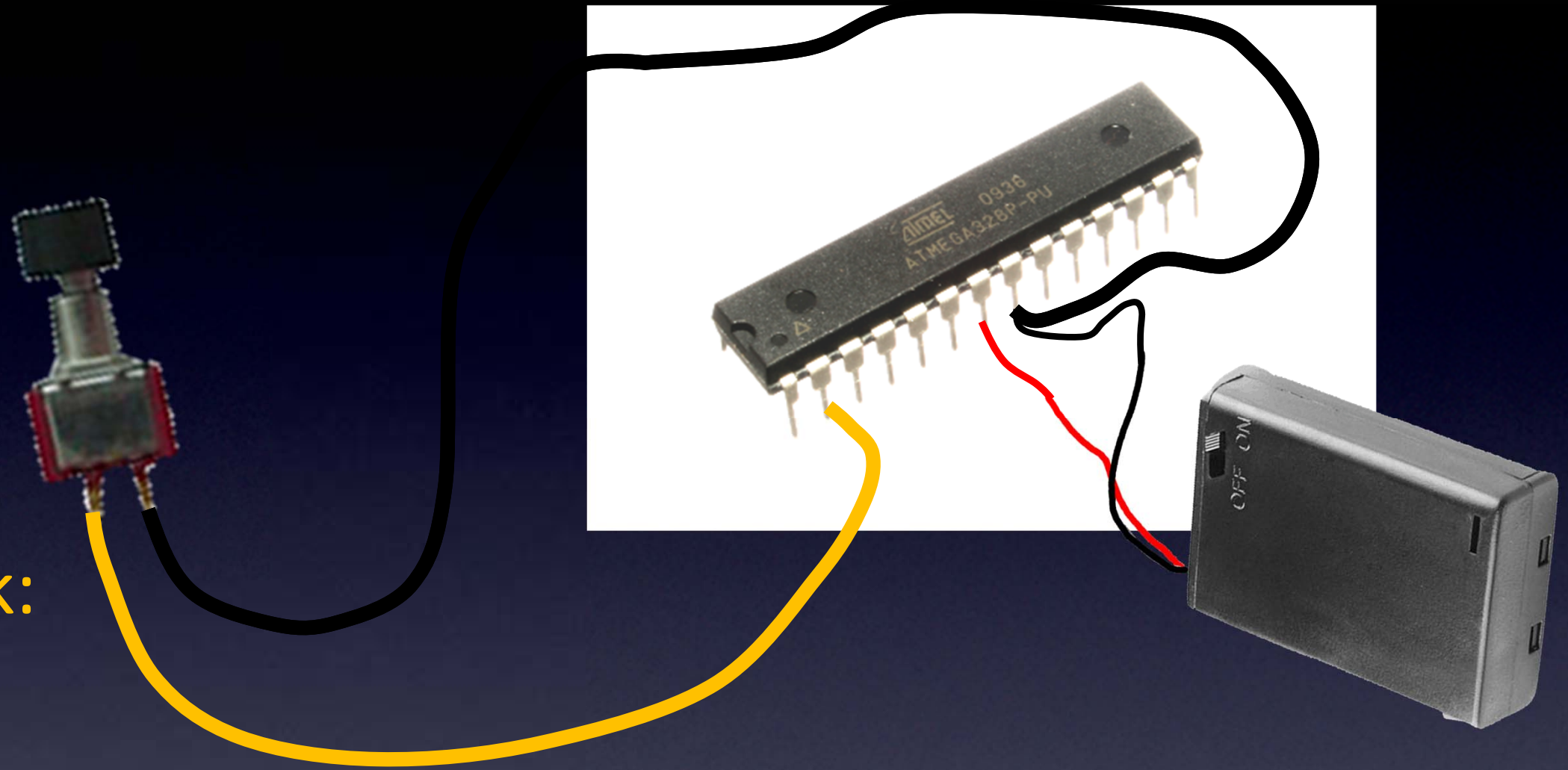

Reading the Input pin, with Switch

Microcontroller – Input pins

Everything You Need to Know About Electronics

Hardware

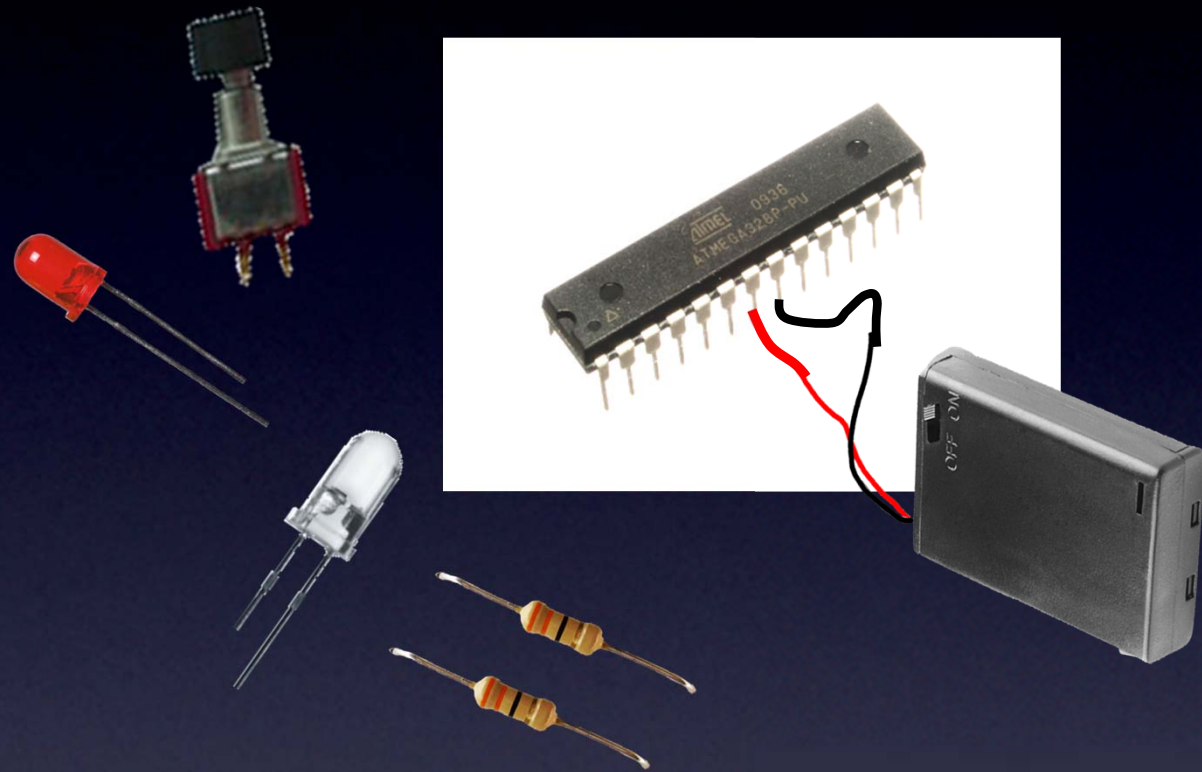

Firmware

Pin 13 Output – visible LED pin

Pin 3 Output – IR LED pin

Pin 2 Input – Push Button

Wait for Switch to be Low

Blink visible LED:

High, Delay, Low

Pulse IR LED for Sony “OFF” code:

High, Delay, Low, Delay...

Blink visible LED:

High, Delay, Low

Pulse IR LED for Panasonic “OFF” code:

High, Delay, Low, Delay...

Etc for all “OFF” codes

TV-B-Gone remote control

Microcontroller

Everything You Need to Know About Electronics

Hardware

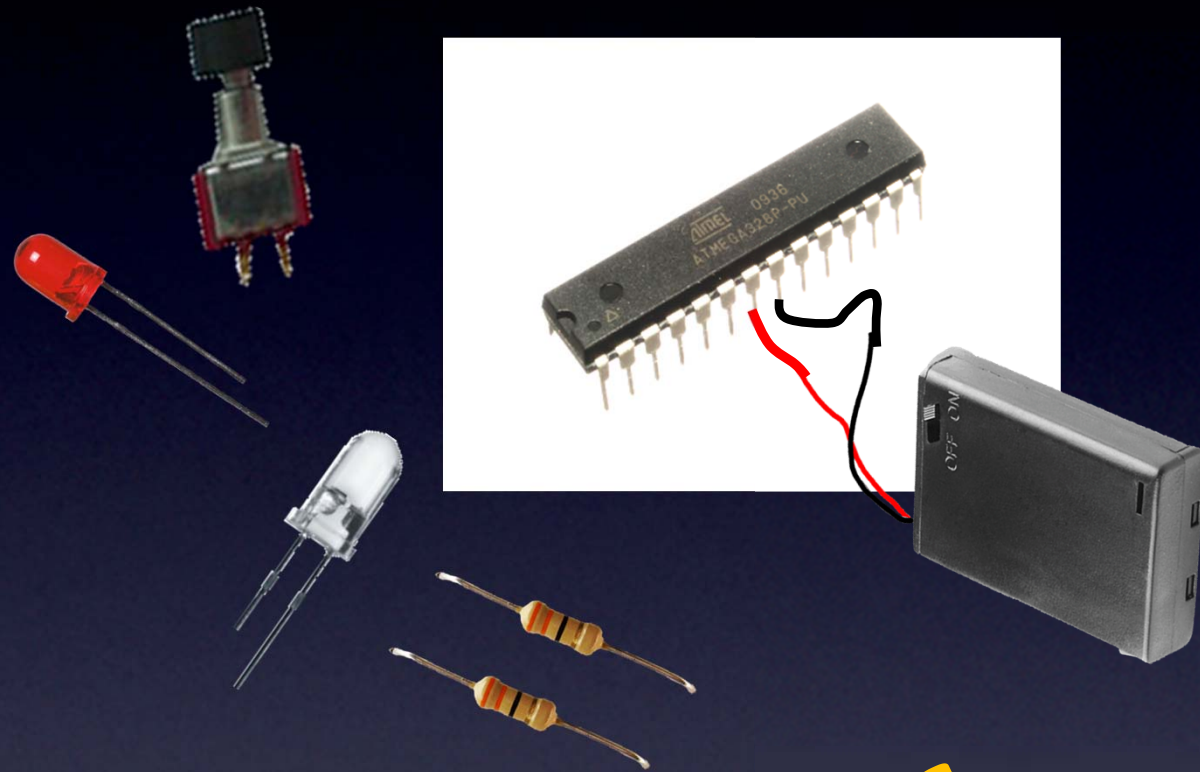

Except
doesn't go very far

Firmware

Pin 13 Output – visible LED pin

Pin 3 Output – IR LED pin

Pin 2 Input – Push Button

Wait for Switch to be Low

Blink visible LED:

High, Delay, Low

Pulse IR LED for Sony “OFF” code:

High, Delay, Low, Delay...

Blink visible LED:

High, Delay, Low

Pulse IR LED for Panasonic “OFF” code:

High, Delay, Low, Delay...

Etc for all “OFF” codes

TV-B-Gone remote control

Microcontroller

Everything You Need to Know About Electronics

Review:

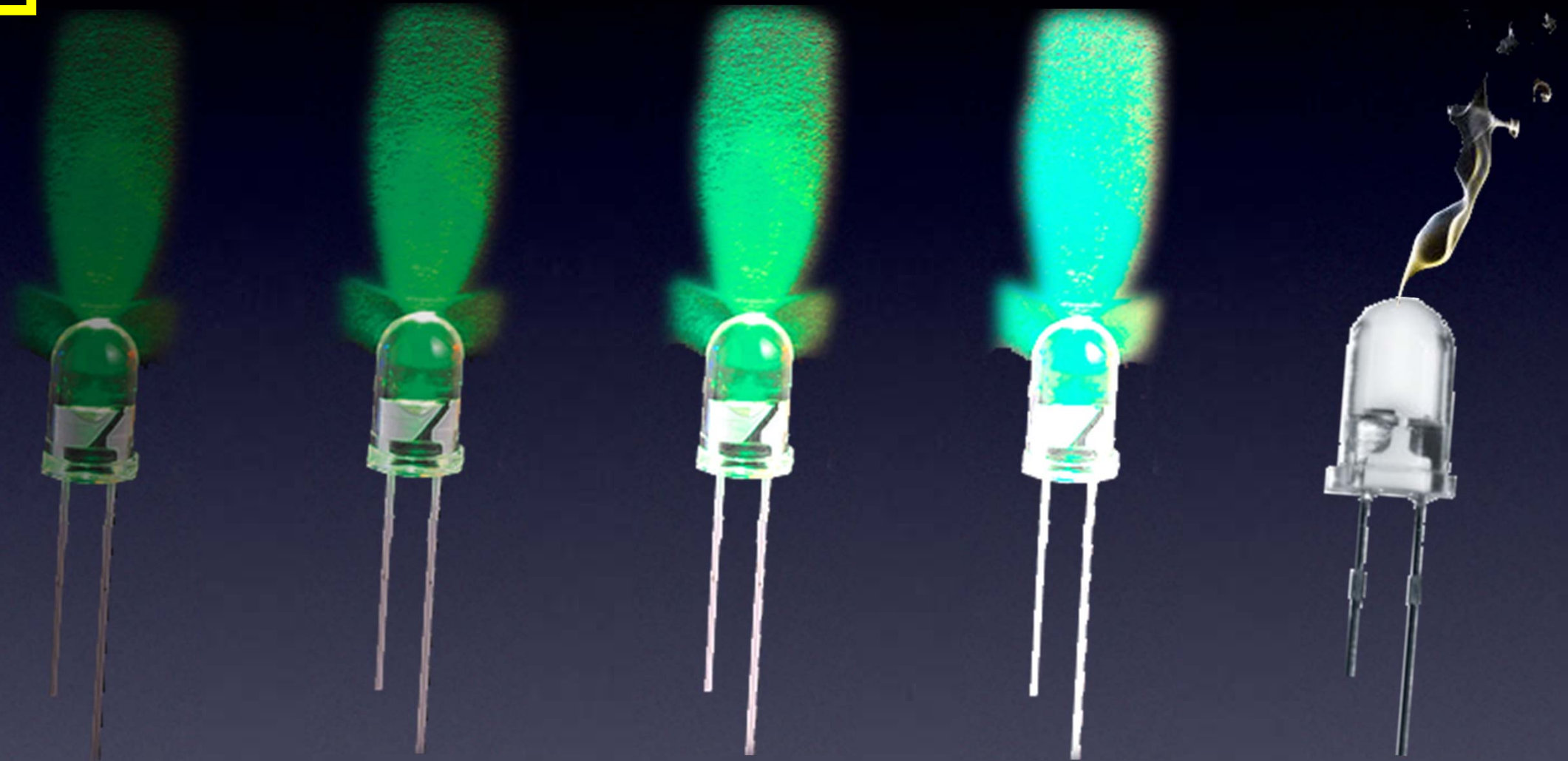

More current \rightarrow More brightness! (until...)

LED

Everything You Need to Know About Electronics

Output pin – only 2 choices:

Low

High

Off

On

(0V)

(Power supply voltage

-- *controlled by our Firmware!*)

Output pins

only allow

limited current

(built-in resistors on each pin)



Microcontroller – Output pins

Everything You Need to Know About Electronics



dimly lit LED

Output pin – only 2 choices:

Low

High

Off

On

(0V)

(Power supply voltage

-- controlled by our Firmware!)

So,
IR LED
can only light up
dimly
from the Output pin

Output pin – only limited current

Microcontroller – Output pins

Everything You Need to Know About Electronics

So,
let's amplify
the current
from the Output pin

with
a

Current amplifier !

Everything You Need to Know About Electronics

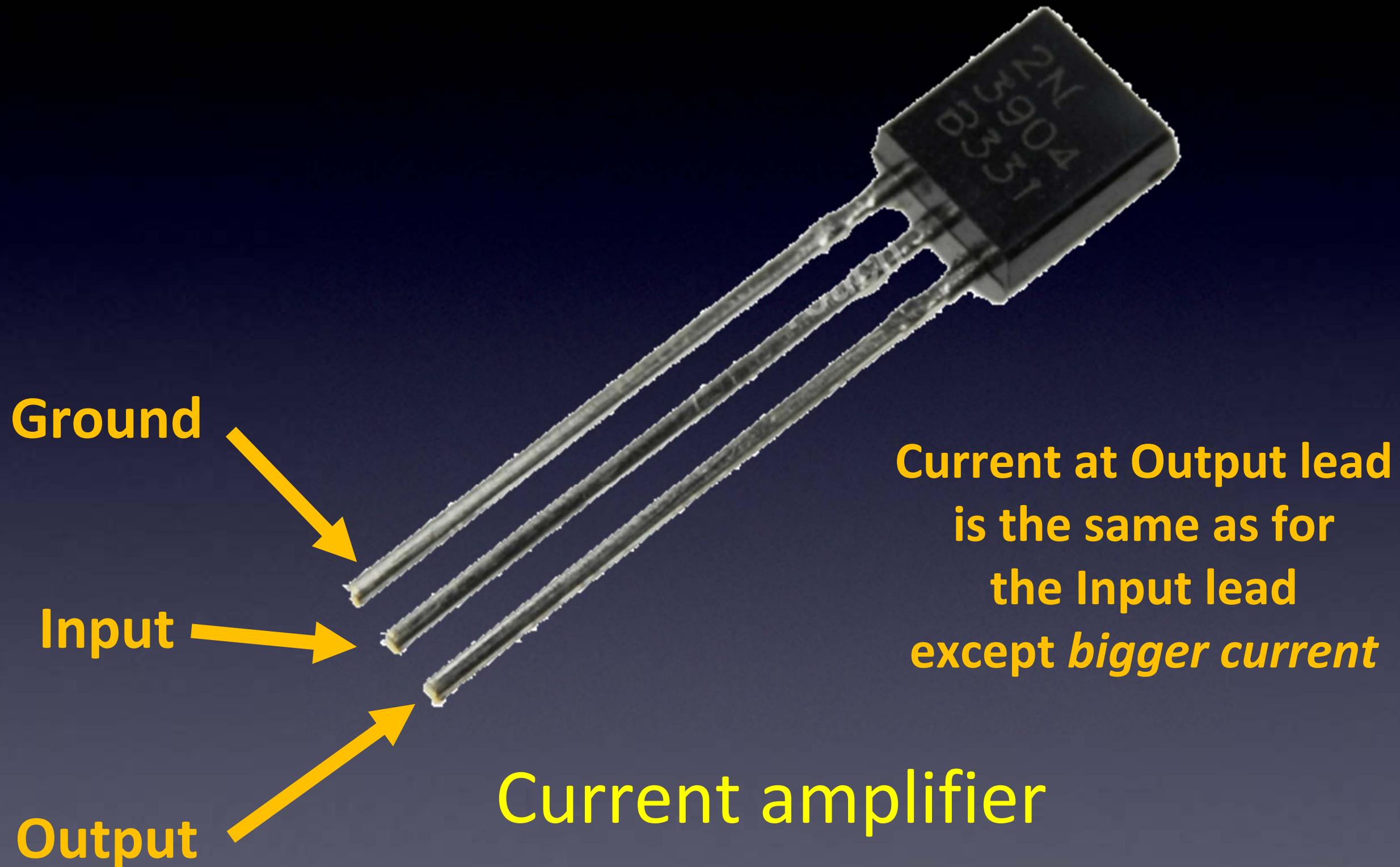

Transistor

Everything You Need to Know About Electronics

Hardware

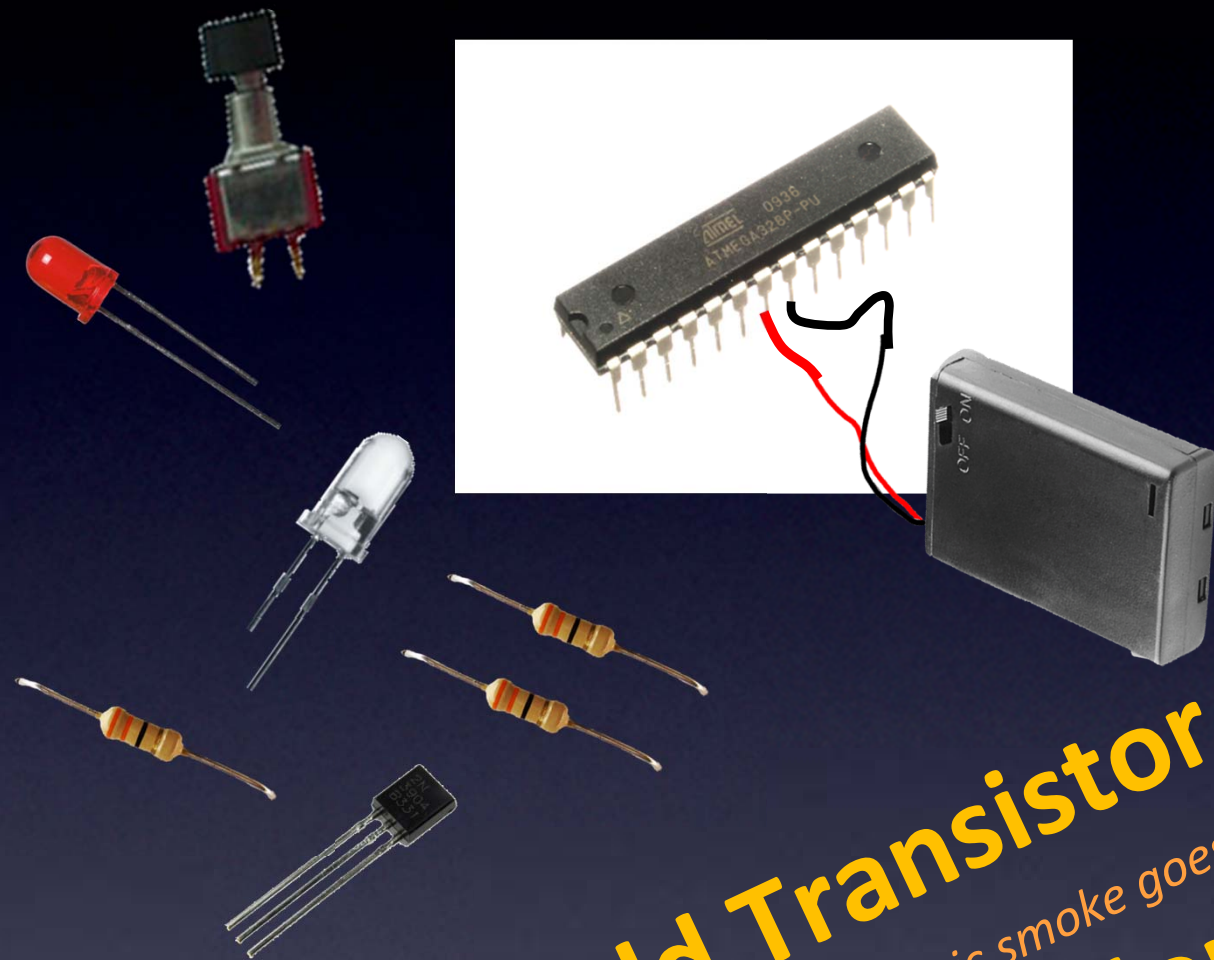

Add Transistor
(and a resistor so no magic smoke goes away)
and, we're done!

Firmware

Pin 13 Output – visible LED pin

Pin 3 Output – IR LED pin

Pin 2 Input – Push Button

Wait for Switch to be Low

Blink visible LED:

High, Delay, Low

Pulse IR LED for Sony “OFF” code:

High, Delay, Low, Delay...

Blink visible LED:

High, Delay, Low

Pulse IR LED for Panasonic “OFF” code:

High, Delay, Low, Delay...

Etc for all “OFF” codes

TV-B-Gone remote control – we're done!

Microcontroller

And, that is

And, that is

Everything You Need to Know About
Electronics

Questions?

Learn To Solder

SOLDERING IS EASY *HERE'S HOW TO DO IT*

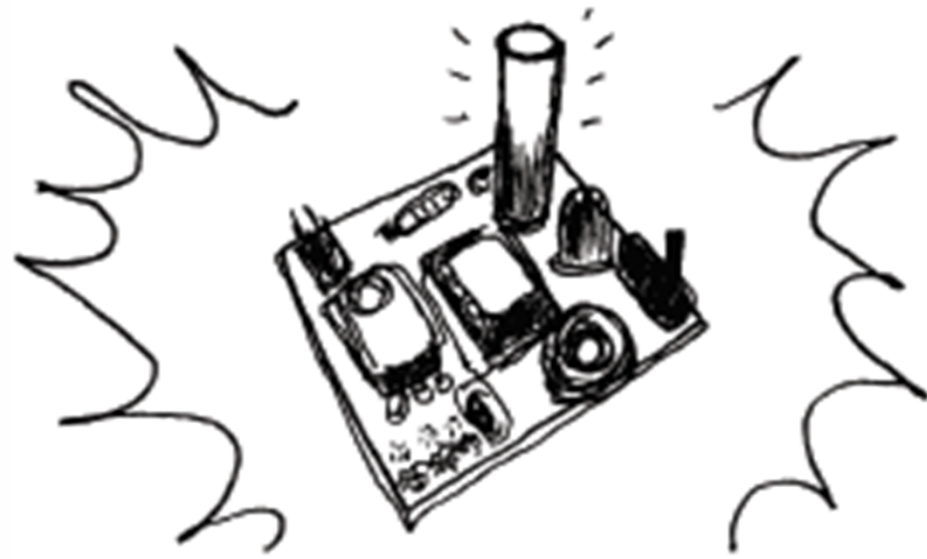

BY: **MITCH ALTMAN**
(*SOLDERING WISDOM*)

ANDIE NORDGREN
(*COMICS ADAPTATION*)

JEFF KEYZER
(*LAYOUT AND EDITING*)

DOWNLOAD THIS COMIC BOOK AND
SHARE IT WITH YOUR FRIENDS!
[HTTP://MIGHTYOHM.COM/SOLDERCOMIC](http://mightyohm.com/soldercomic)



DISTRIBUTE WIDELY!



download for free at:
<http://mightyohm.com/soldercomic>

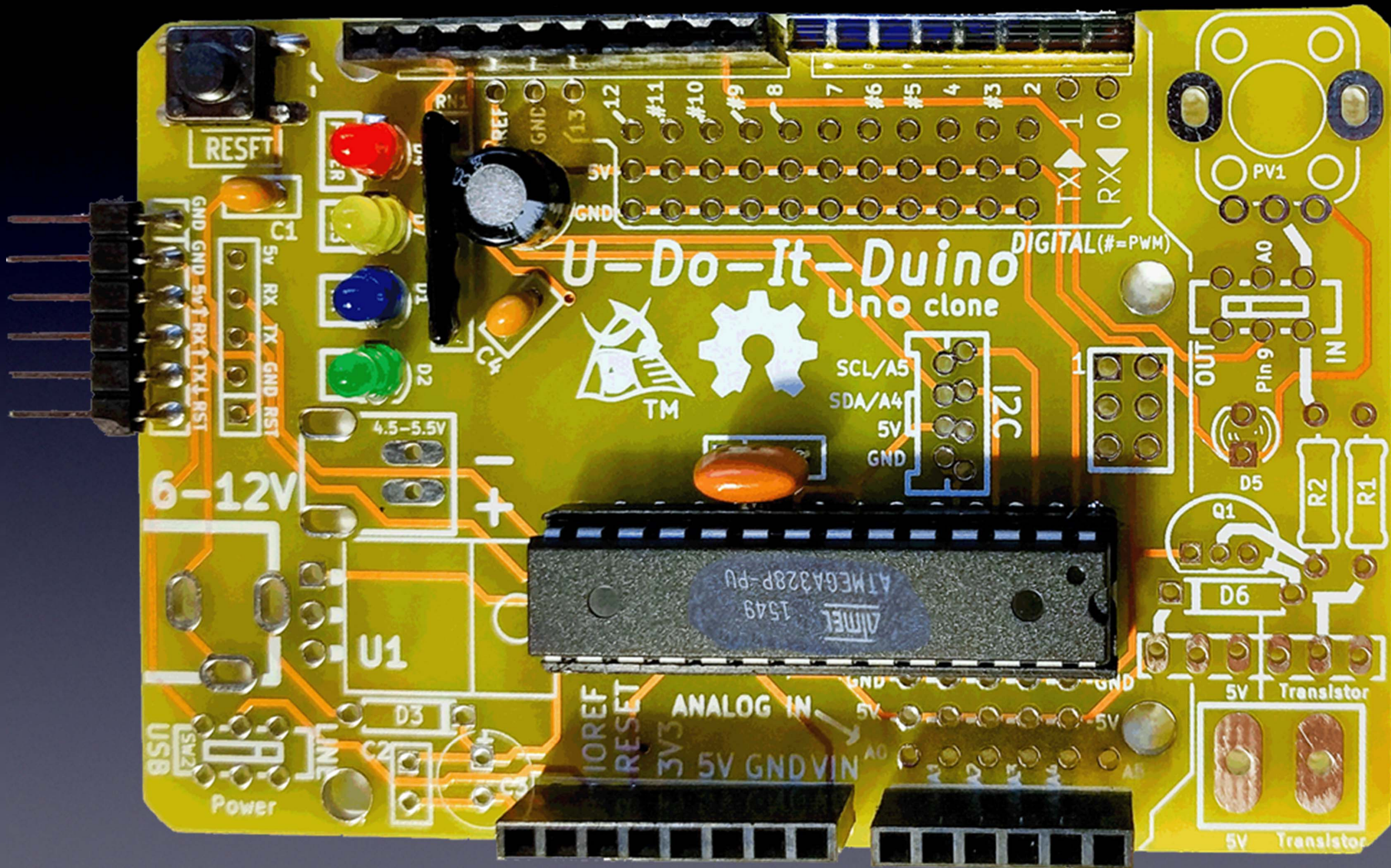

U-Do-It-Duino
Uno clone

ATMEL 1549 ATMEGA328P-PU

6-12V

RESFT

USB

Power

U1

IOREF
RESET
3V3
ANALOG IN
5V
GND
VIN

SCL/A5
SDA/A4
5V
GND

I2C

DIGITAL(=#=PWM)

TX
RX
0

5V Transistor

5V Transistor

PV1
A0
Pin 9
OUT
IN

D5

D6

Q1

R2

R1

REF0
GND

12

#11

#10

#9

8

7

#6

#5

4

#3

2

1

0

D1

D2

D3

D4

D5

D6

D7

D8

D9

D10

D11

D12

D13

D14

D15

D16

D17

D18

D19

D20

D21

D22

D23

D24

D25

D26

D27

D28

D29

D30

D31

D32

D33

D34

D35

D36

D37

D38

D39

D40

D41

D42

D43

D44

D45

D46

D47

D48

D49

D50

Parts to use

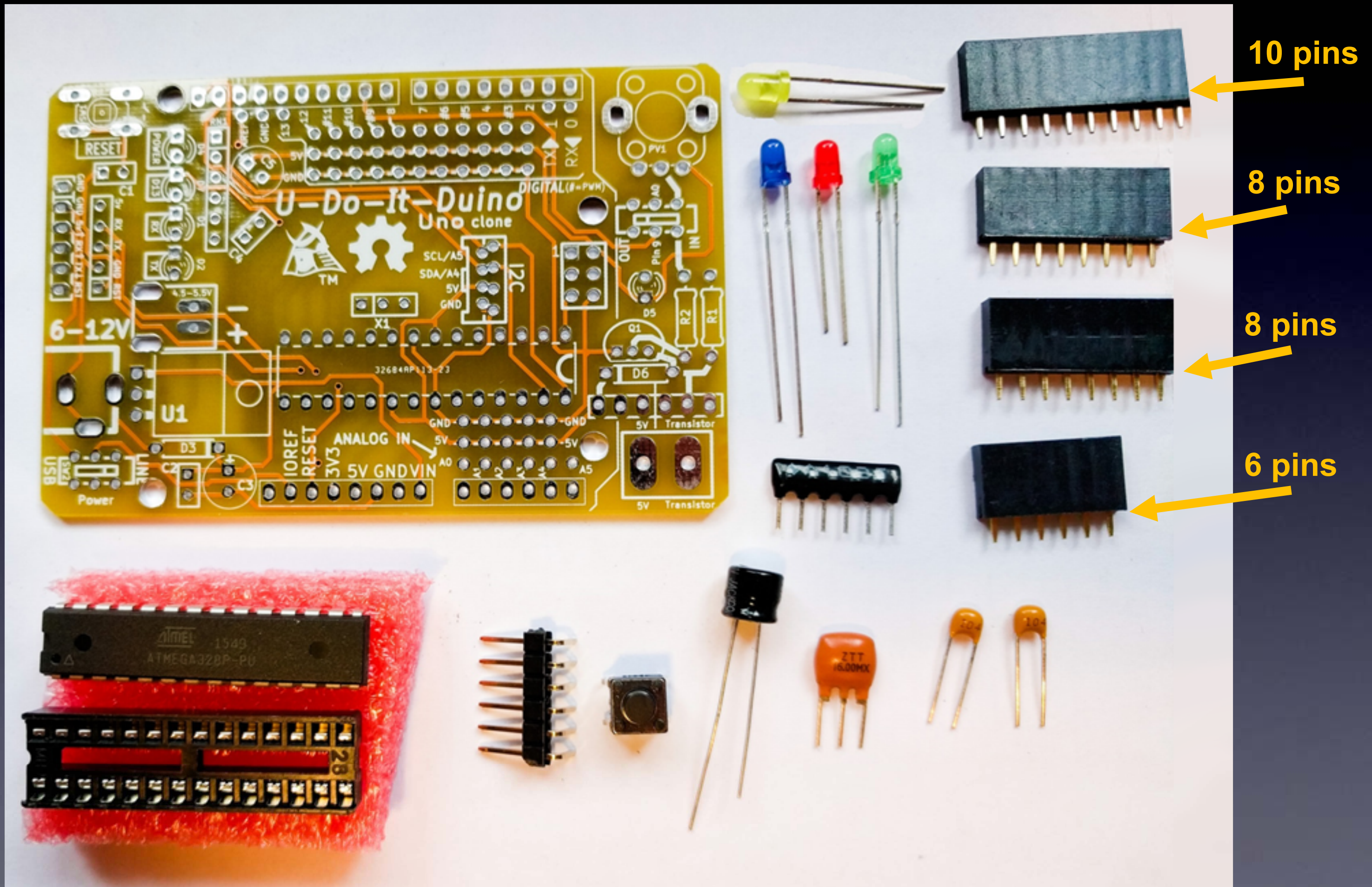

Unused parts

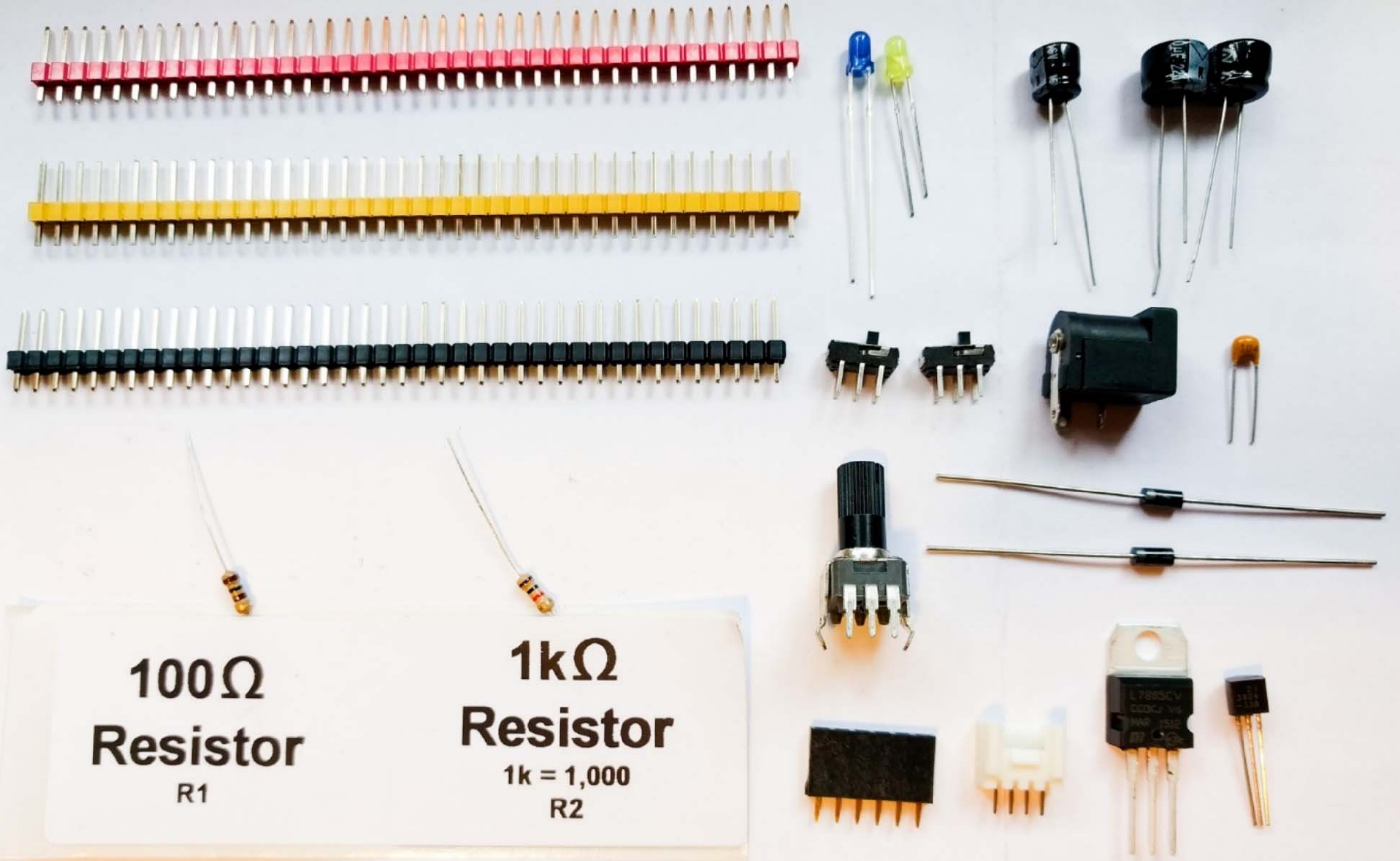

Our first part to solder: C1

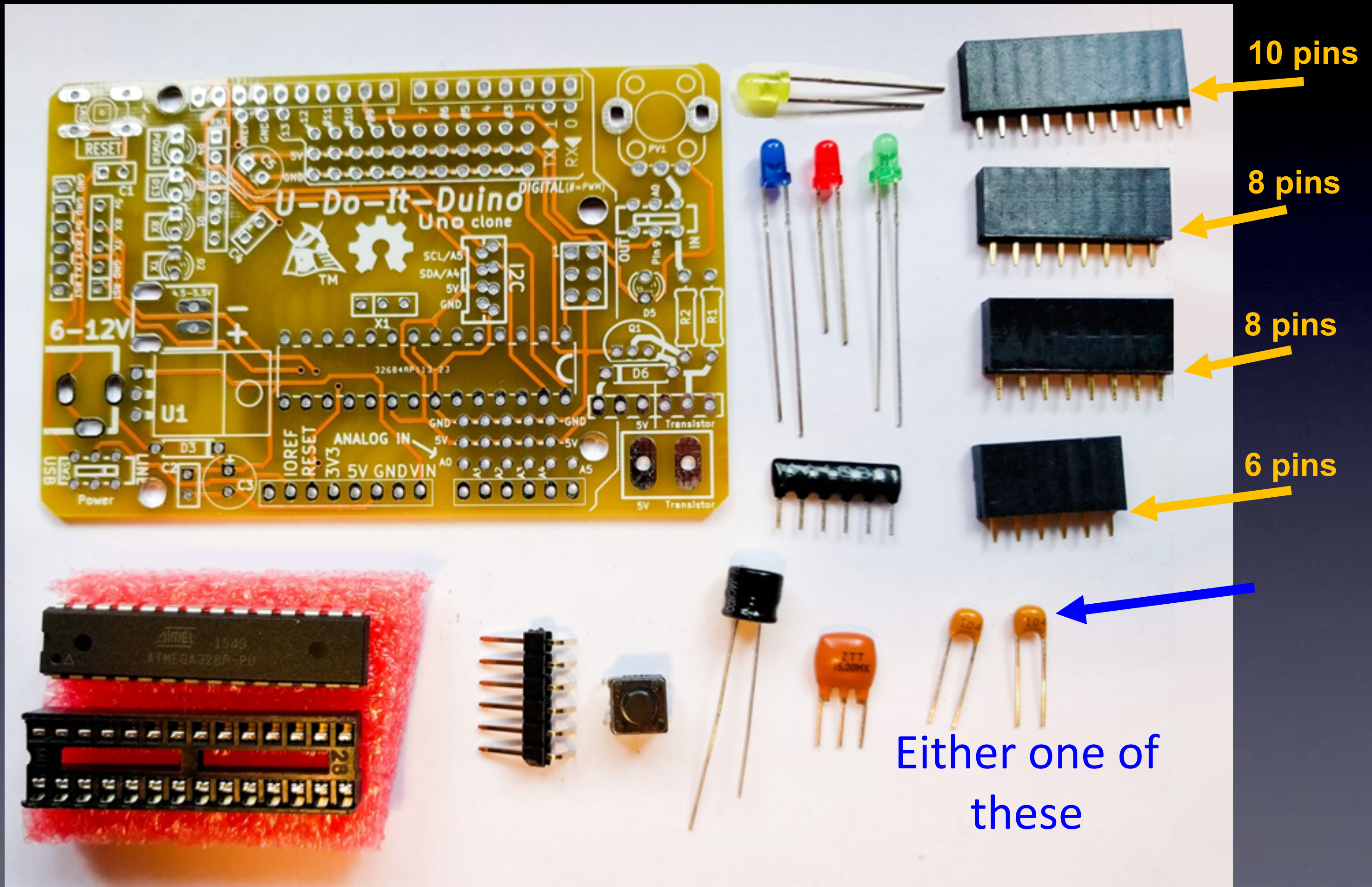

C1: Look down at the shape of this part



U-Do-It-Duino

Uno clone

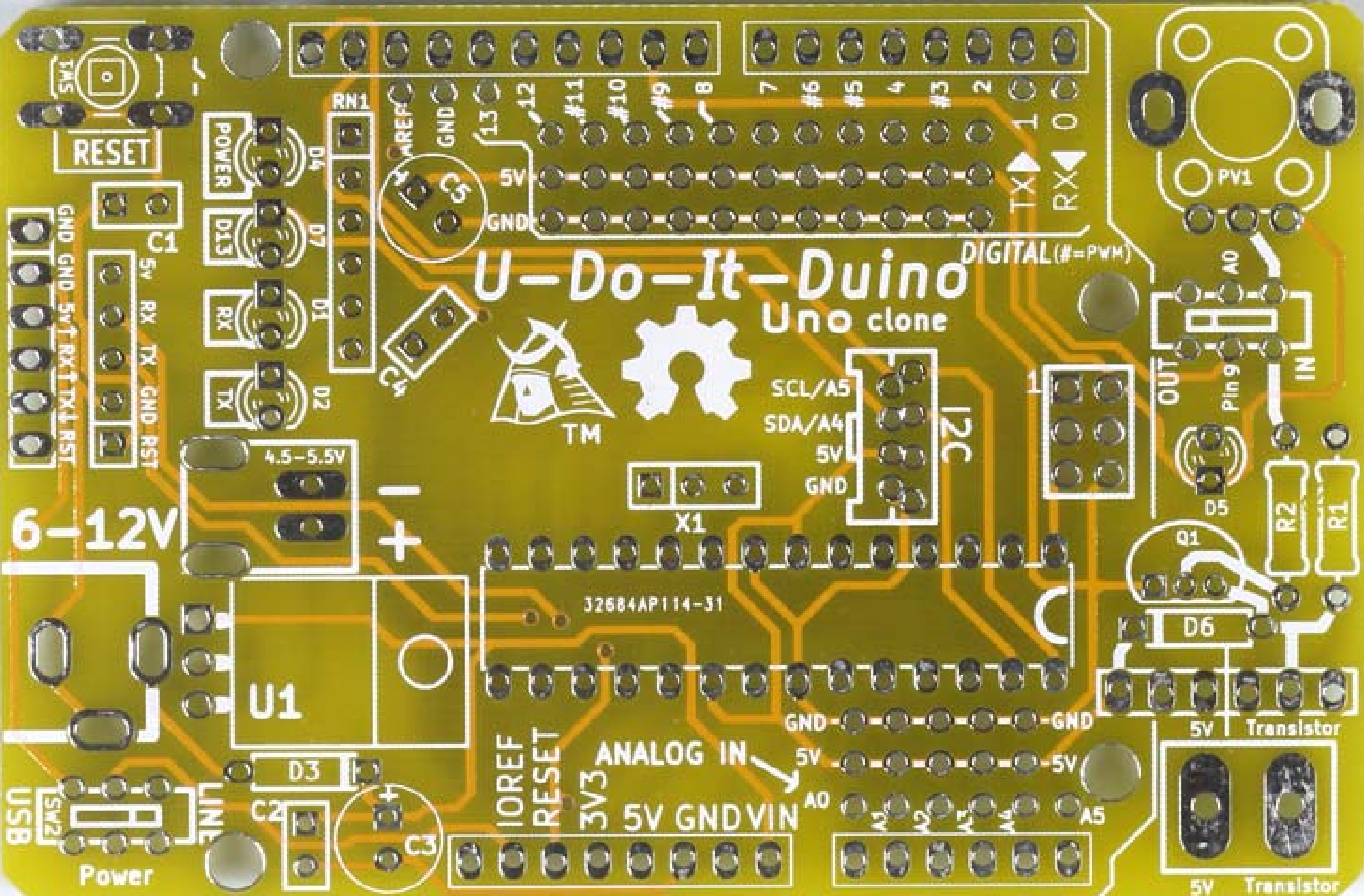

6-12V

DIGITAL (#=PWM)

I2C

3284AP114-31

IOREF
RESET

ANALOG IN
3V3
5V GND VIN

5V Transistor

5V Transistor

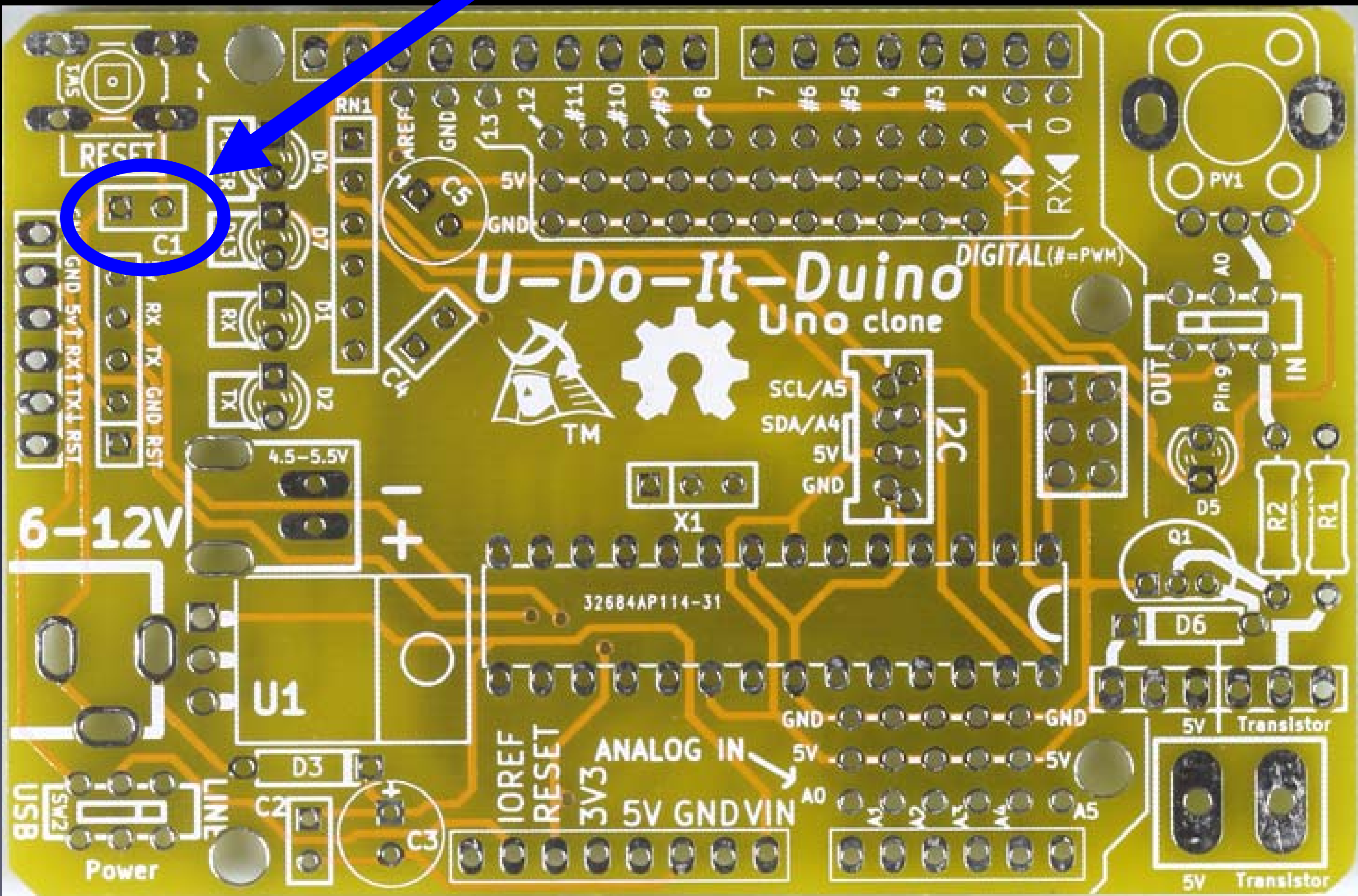

U-Do-It-Duino
Uno clone

DIGITAL (#=PWM)

6-12V

Power
USB

IOREF
RESET
3V3
5V GND VIN

SCL/A5
SDA/A4
5V
GND

I2C

5V Transistor

5V Transistor

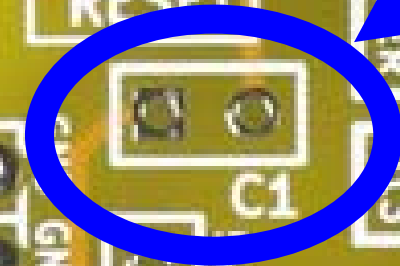

Some parts, such as resistors, need their leads bent first

If necessary, Bend leads
before inserting the part
into the board

wires coming out
from parts are
called “leads” –
they lead to the
part

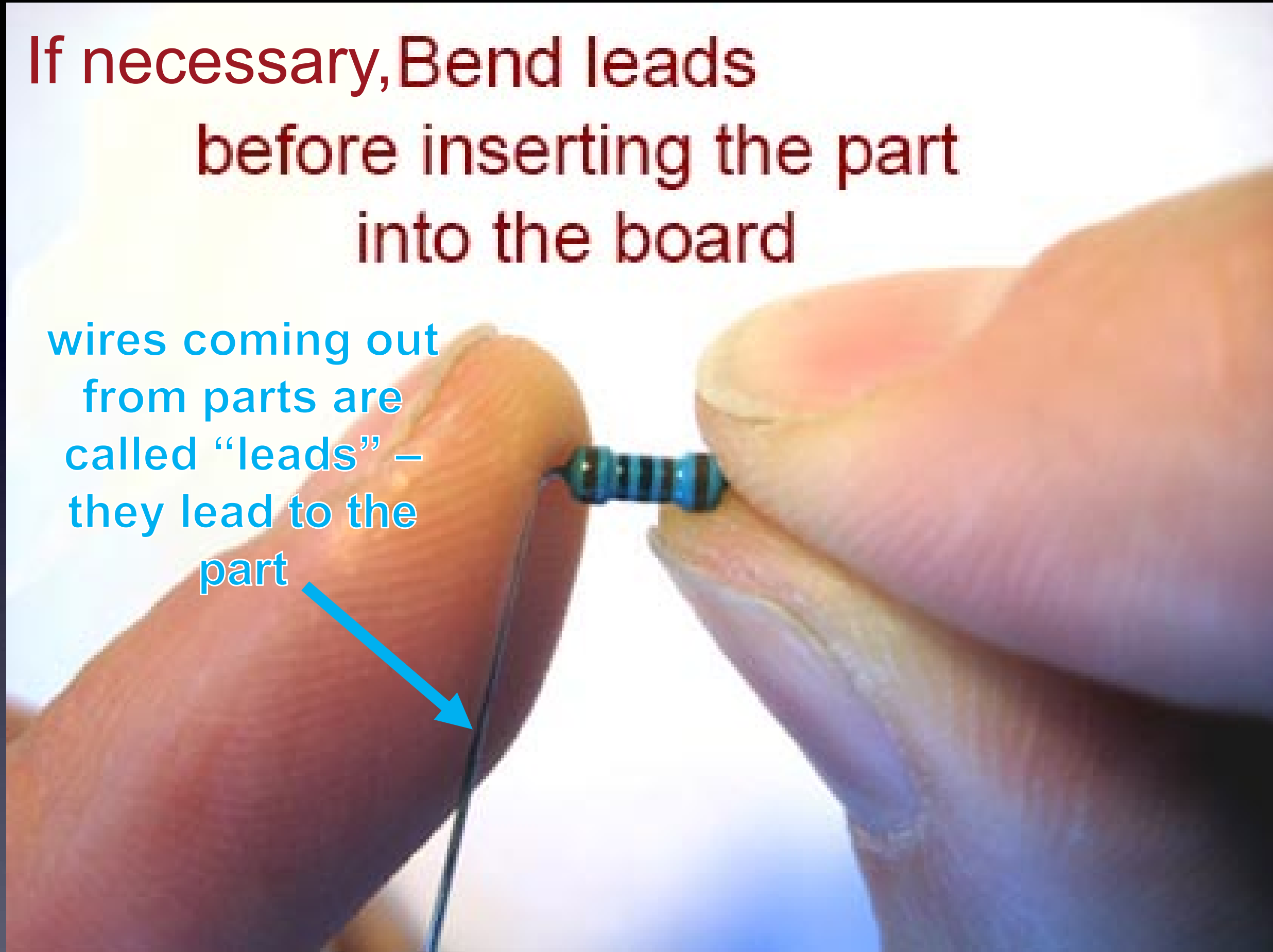

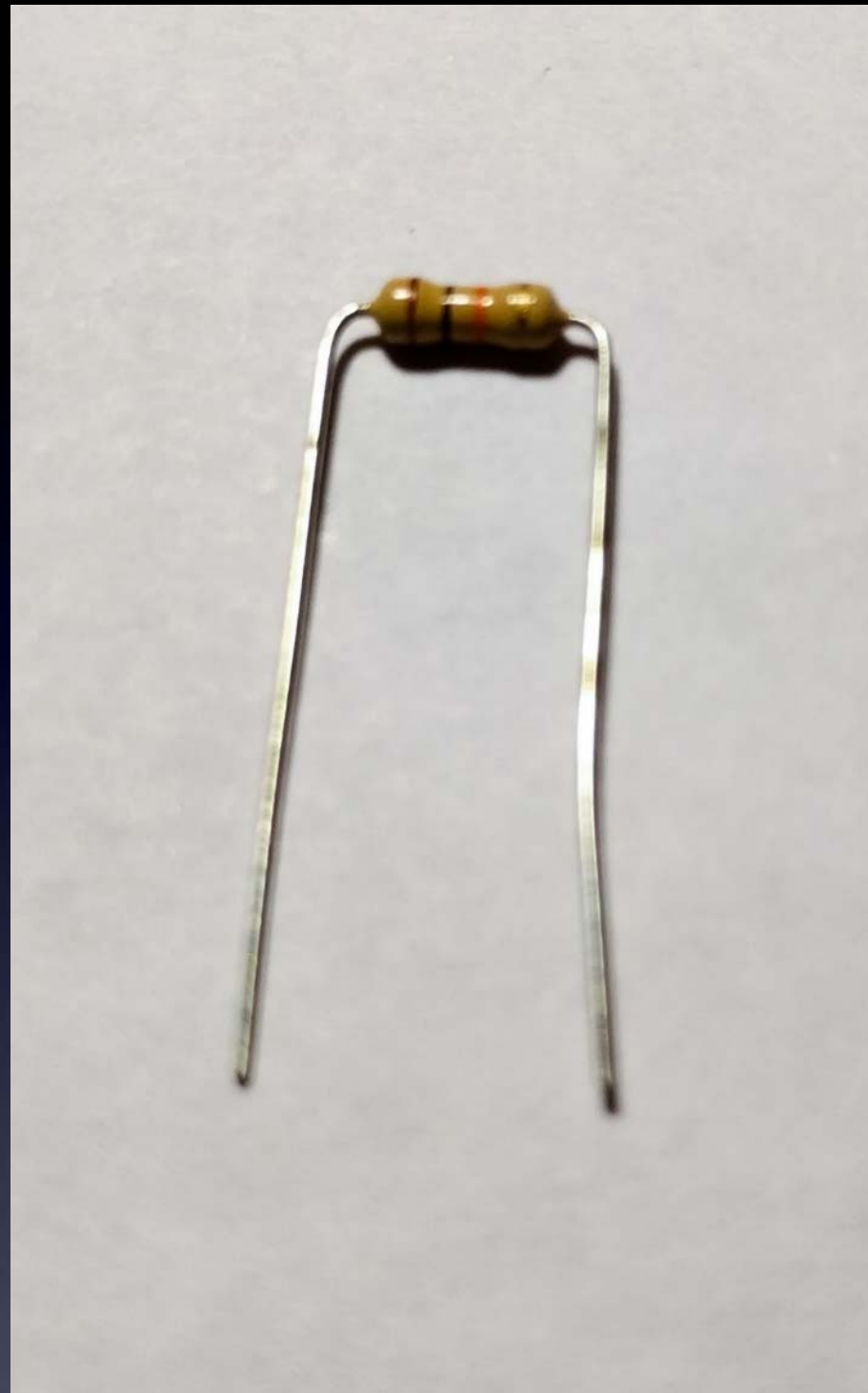

This is how a resistor look *before* inserting it into the board

C1: No need to bend leads first



Insert leads into pads

the circles with holes in them are called "pads"

there is one "pad" per lead for each part

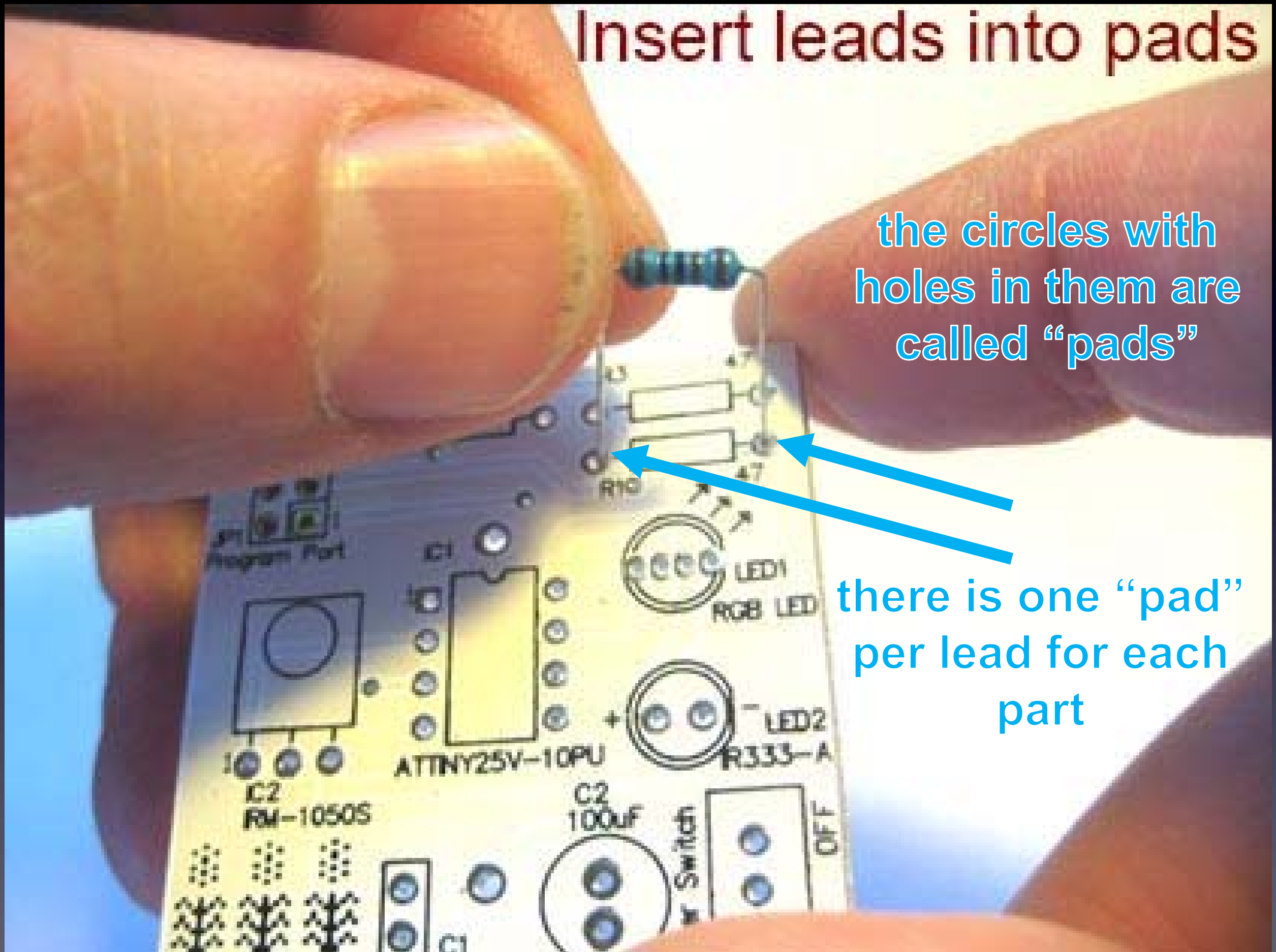

**C1: leads inserted
into their pads**

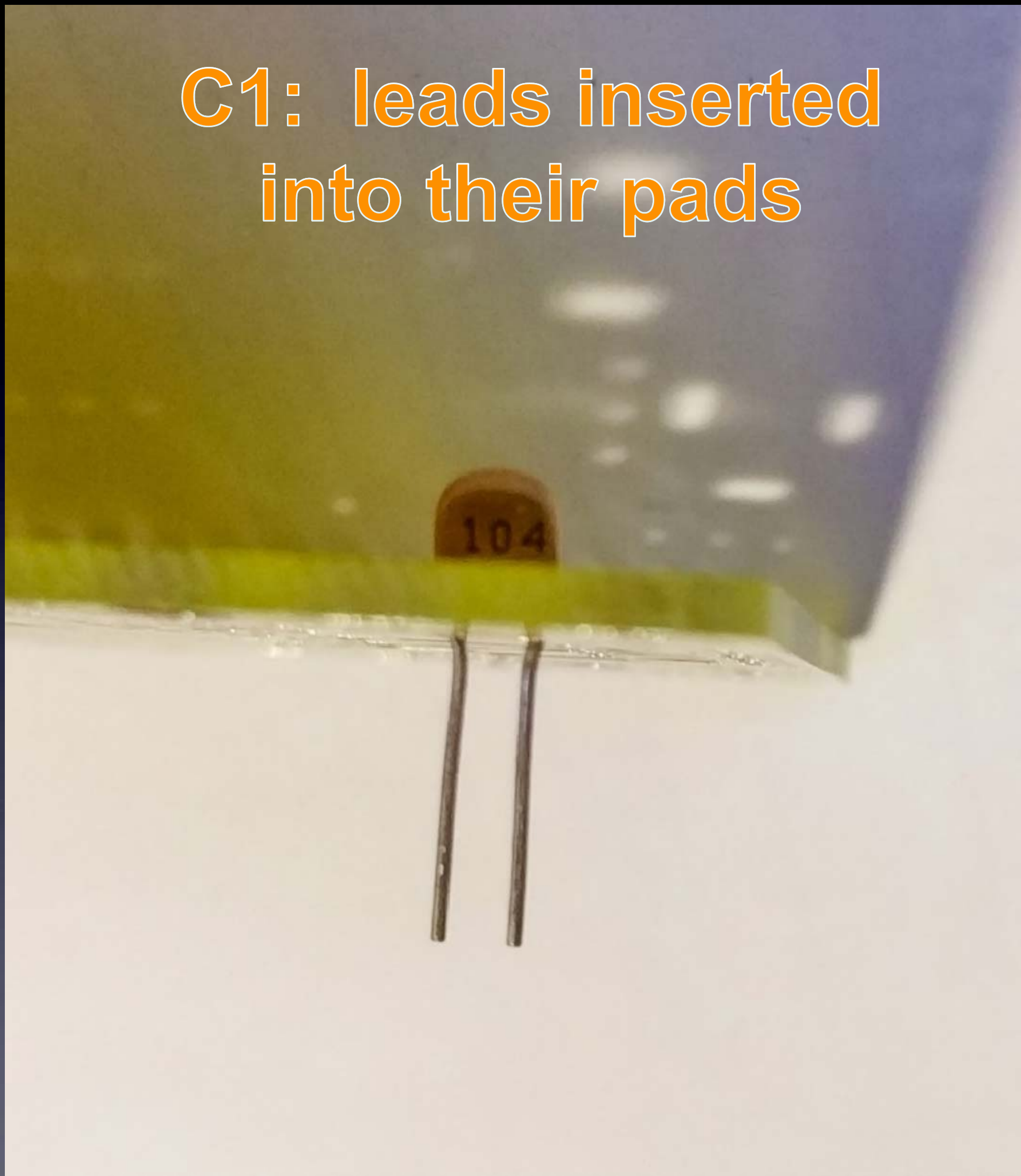

C1: board upside down



Bend leads
half way out

(only half way) like a "V"

so that the part won't fall out while soldering it



How to hold a soldering iron iron

(Like a pencil – held from underneath)

Important

The perfect kind of solder for
electronics:

60/40 rosin core,

0.031" (0.7mm) diameter (or smaller)

(63/37 is also good)

Important:

Use solder WITH lead (Pb) !!
lead-free solder
has very poisonous fumes!

3 Safety Tips...

Safety Tip #1:

Hot !!

(When you touch the tip,
you will let go quickly -- every time!)

Safety Tip #2:

Lead (Pb) is toxic

But it easily washes off your hands
with soap and water

Safety Tip #3:

(coming soon)

2 secrets
to good soldering...

Secret #1:

Clean the tip!

(before every solder connection)

Bang (lightly) 3 times,

Swipe, Rotate, Swipe (on the sponge):

Keep the tip shiny silver!

knock solder off the tip

Lay clean tip across half of the pad,
touching the pad and lead
for 1 second

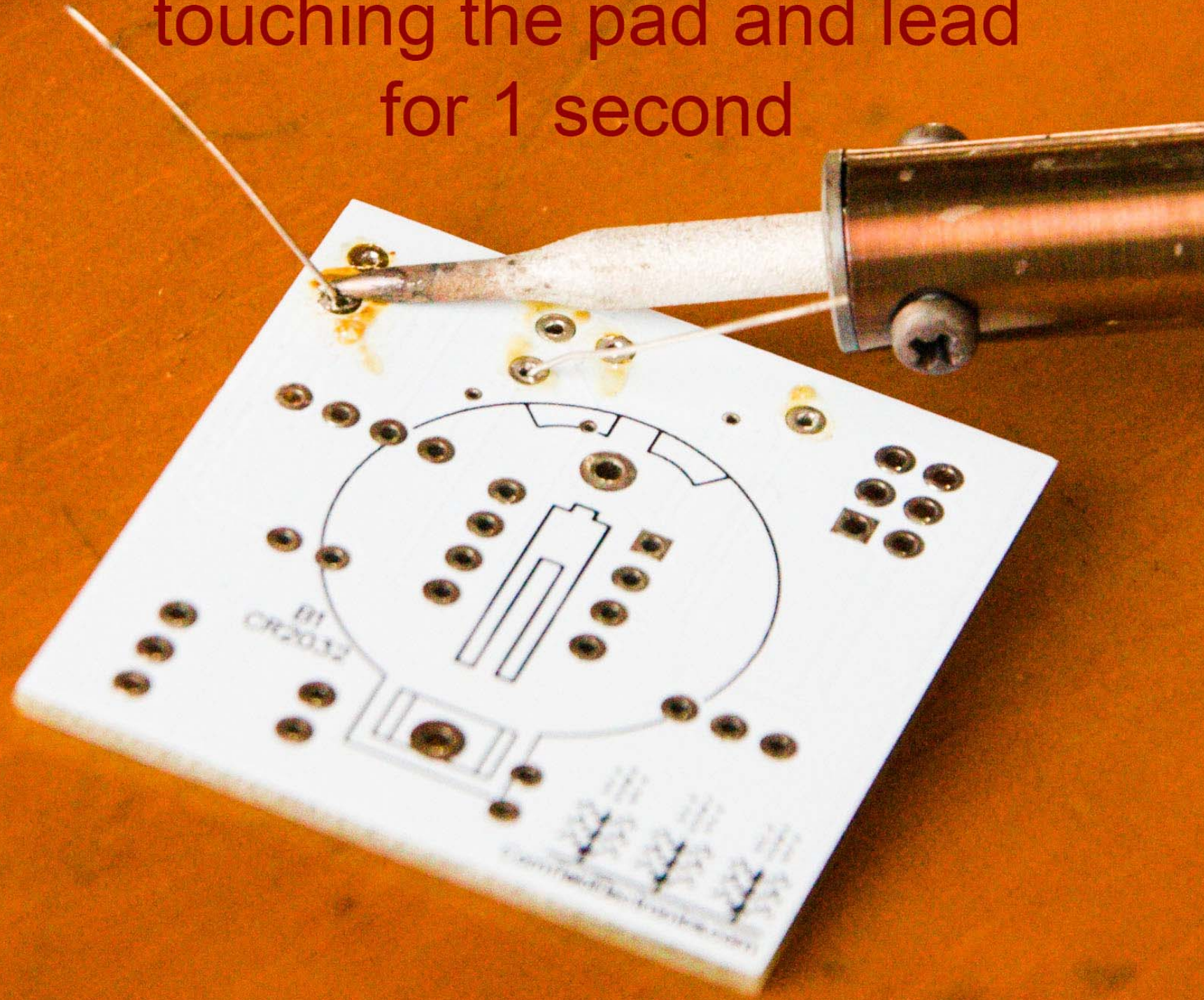

Do this quickly (slowly doesn't work well) – solder in & out in about 1 second

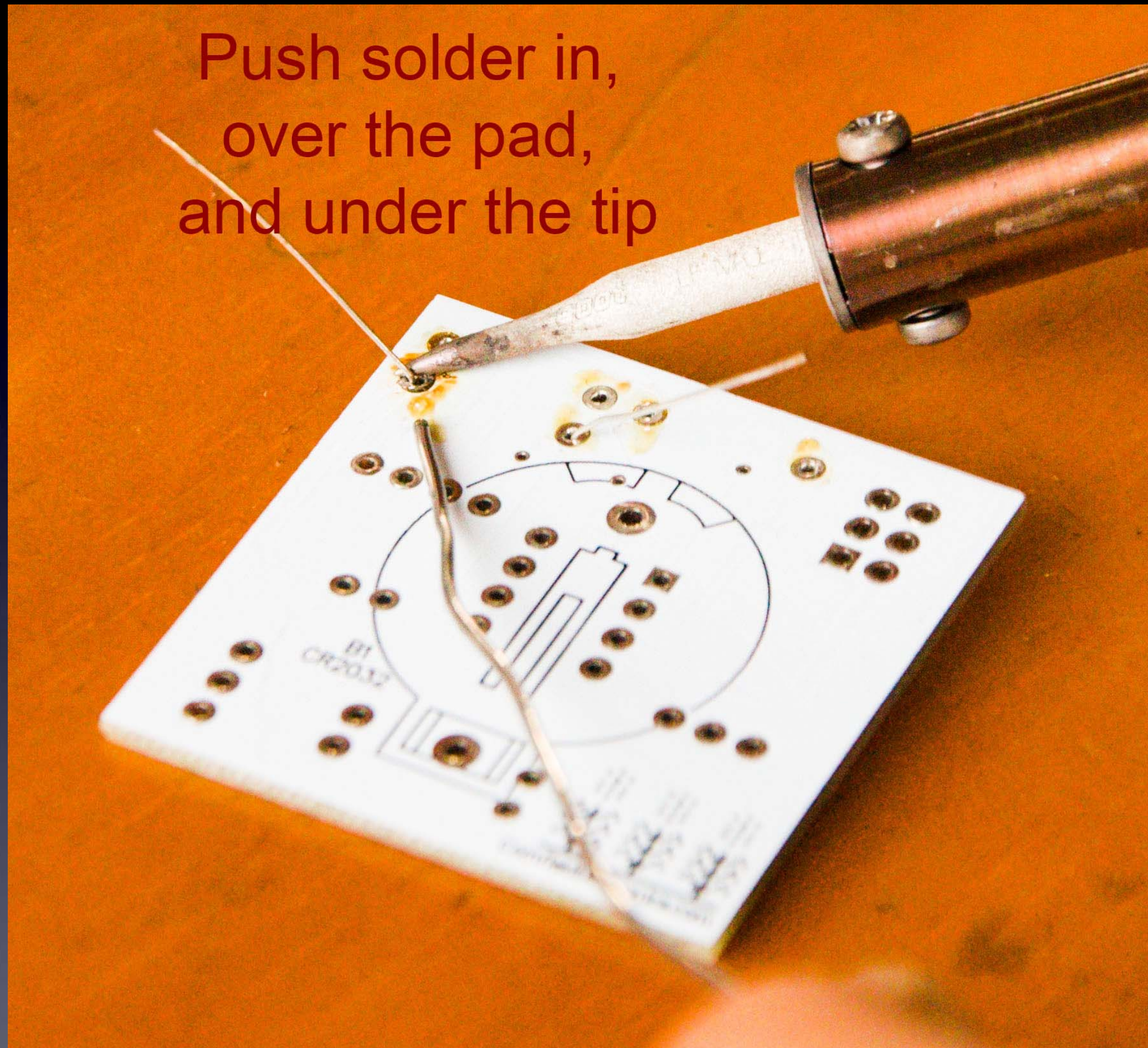

Push solder in,
over the pad,
and under the tip

Make sure solder melts on the underside of the soldering iron tip
(not the side or top of the soldering iron tip)!

Do this quickly (slowly doesn't work well) – solder in & out in about 1 second

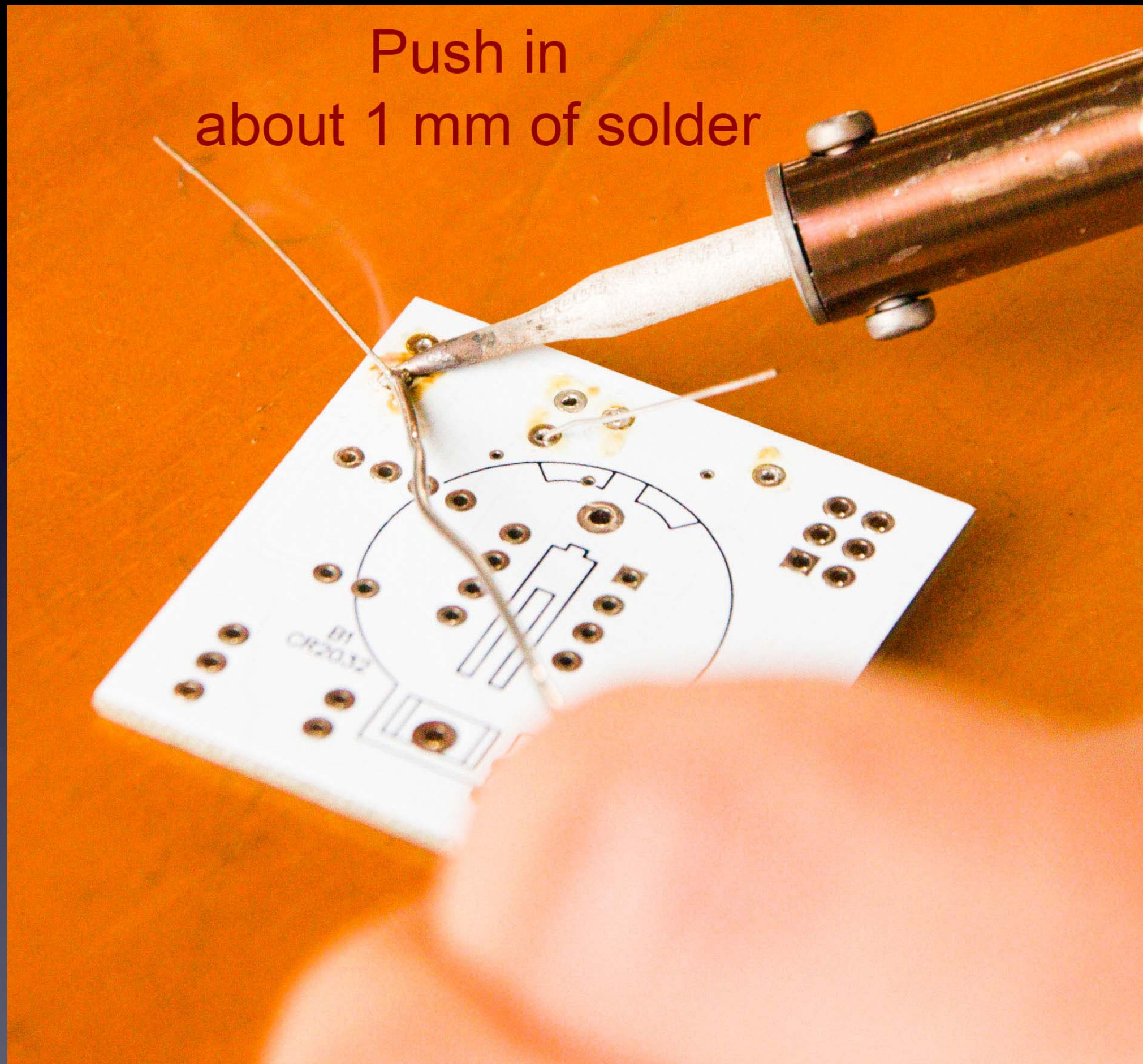

Make sure solder melts on the underside of the soldering iron tip (not the side or top of the soldering iron tip)!

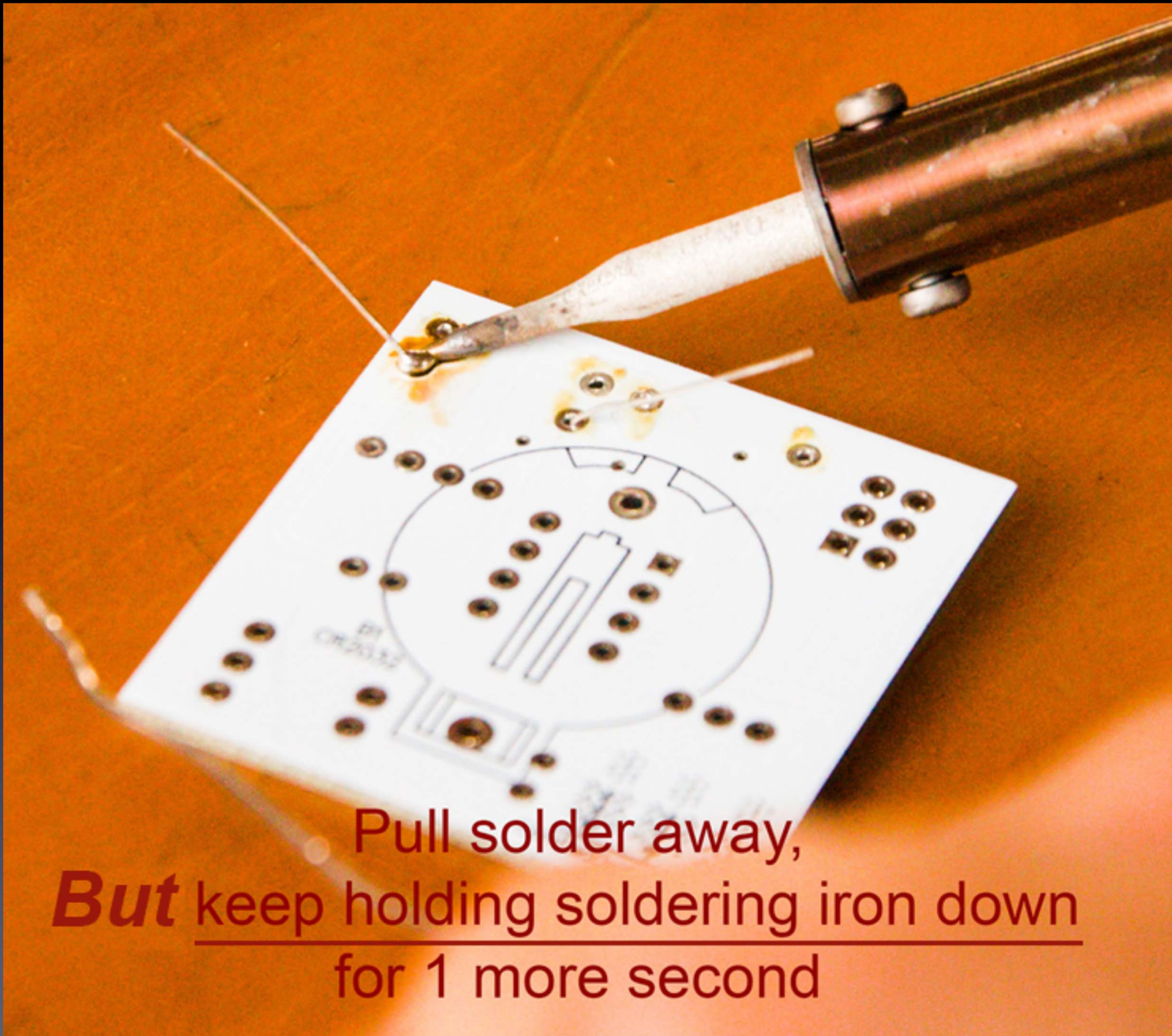

Pull solder away,
But keep holding soldering iron down
for 1 more second

Secret #2:

Keep hot tip down
1 second
for solder to flow !!

Now

Lift soldering iron

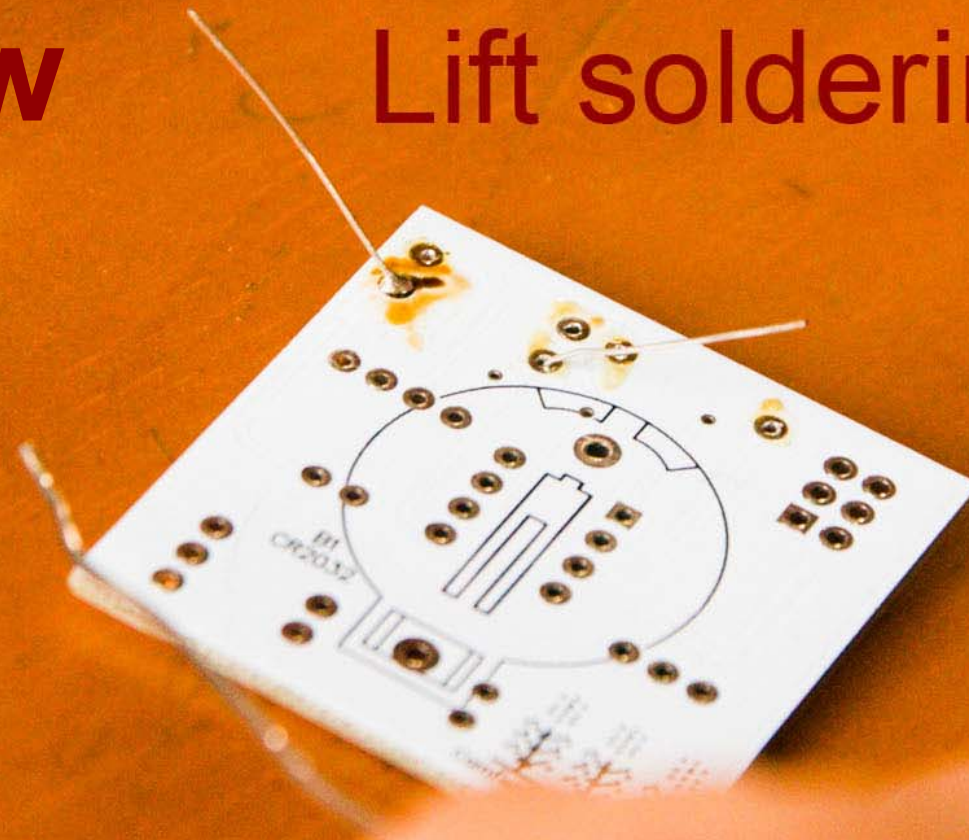

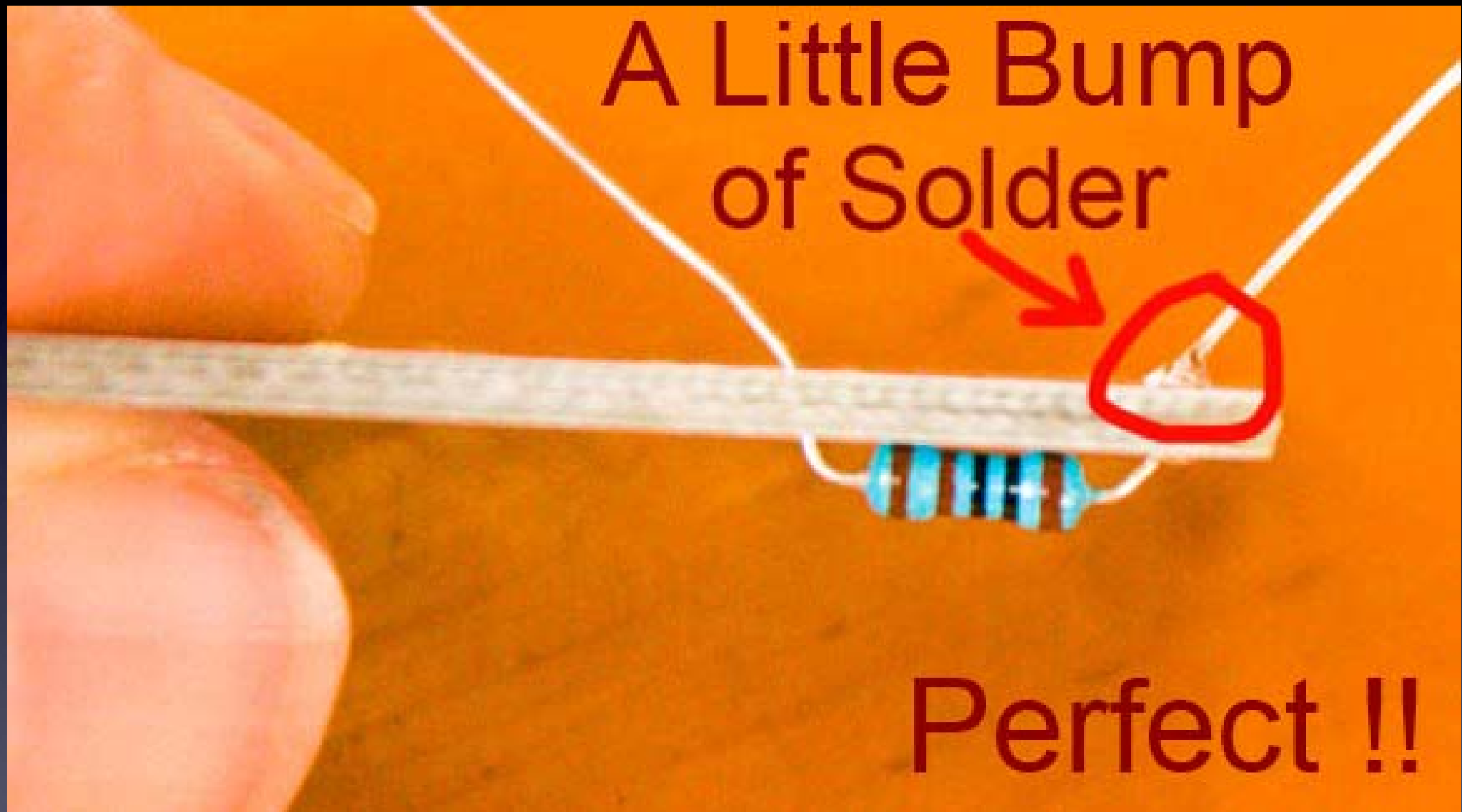

If you can see any of the pad, or the hole, you need more solder
– so, just do all the steps again to make it perfect.

Solder all of the leads of the part to the board

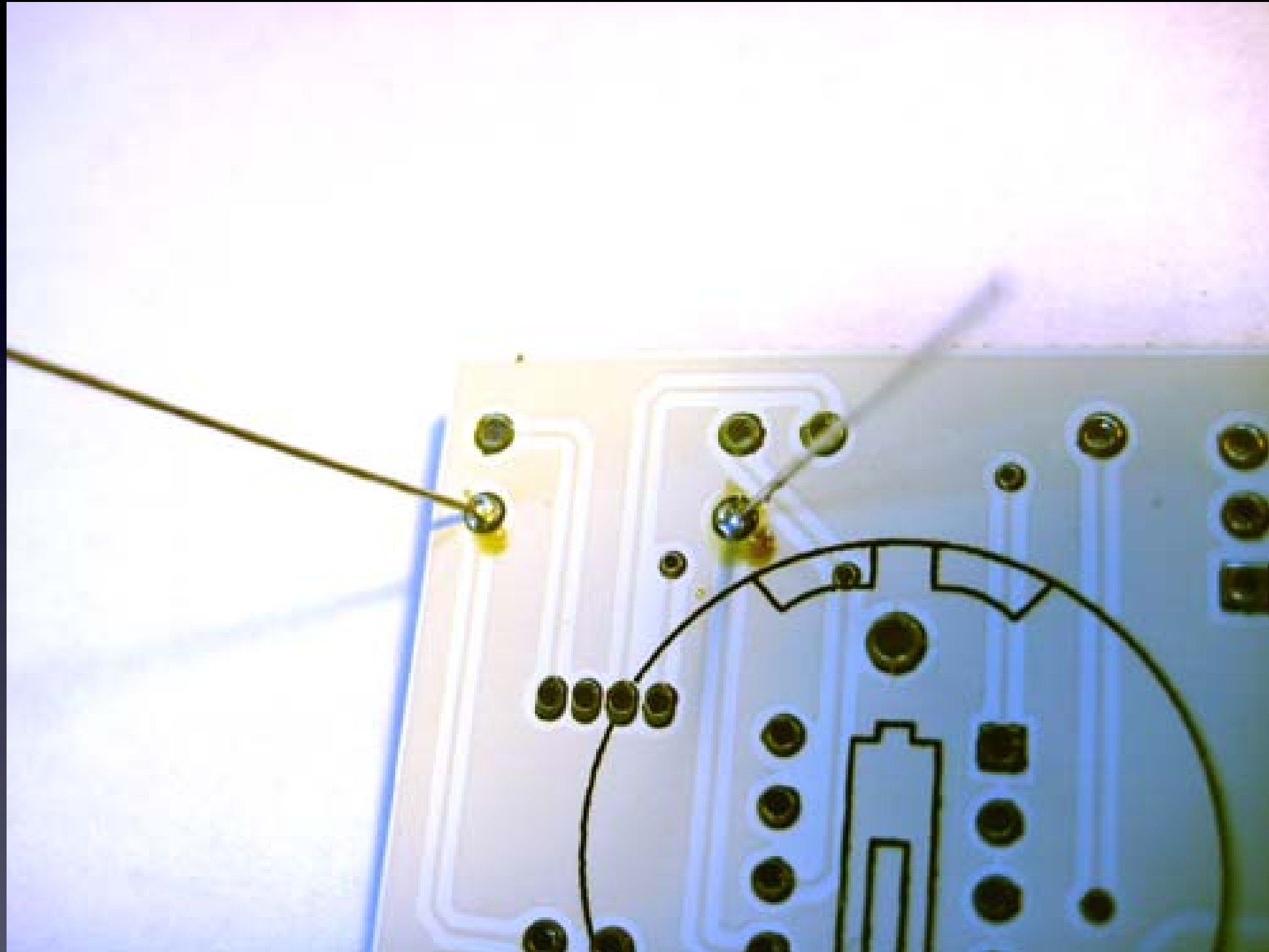

For this part, there are two leads

Here you can see two good solder connections

Now cut the leads short

Hold the lead
while cutting it
all the way down
to the little bump of solder

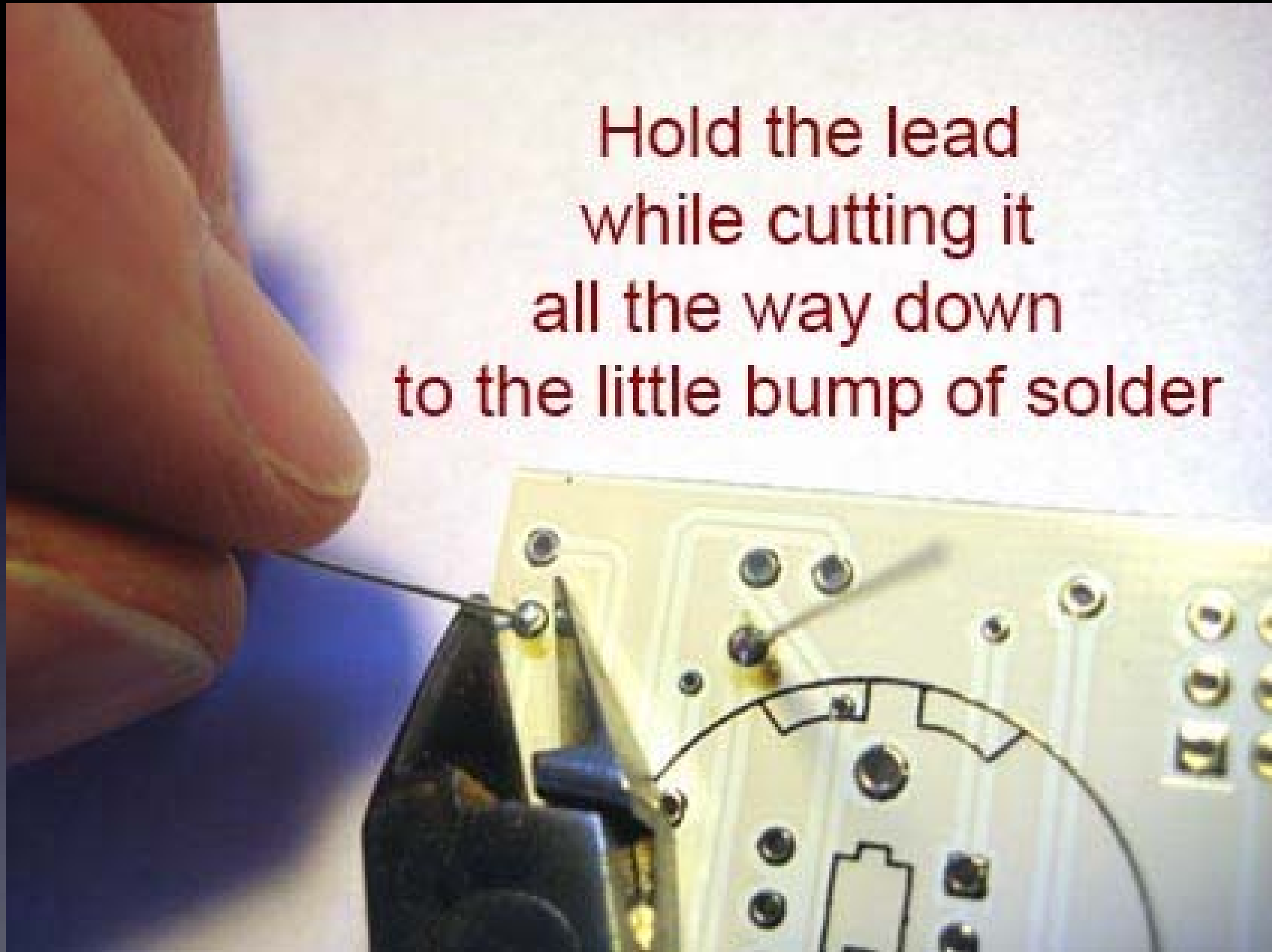

Cutting with the tip of the wire cutter gives you more control

Safety Tip #3:

Hold or cover the lead !

(or it will fly into your eye!)

(They like doing that – so please hold or cover the lead when you cut.)



All done !

No wires sticking out



C1: All done !

No wires sticking out

One part at a time

Till all the parts are soldered

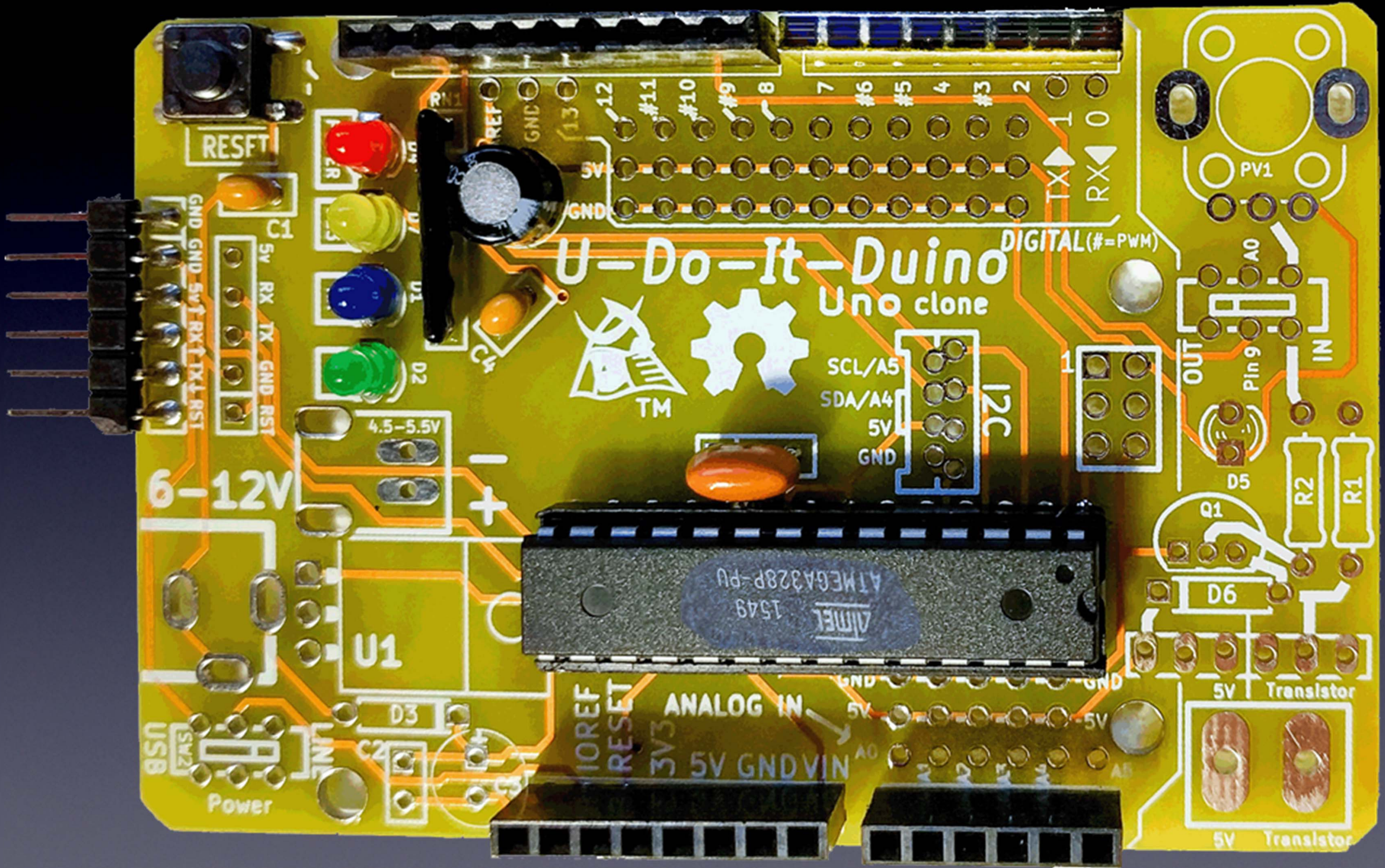

U-Do-It-Duino

Uno clone

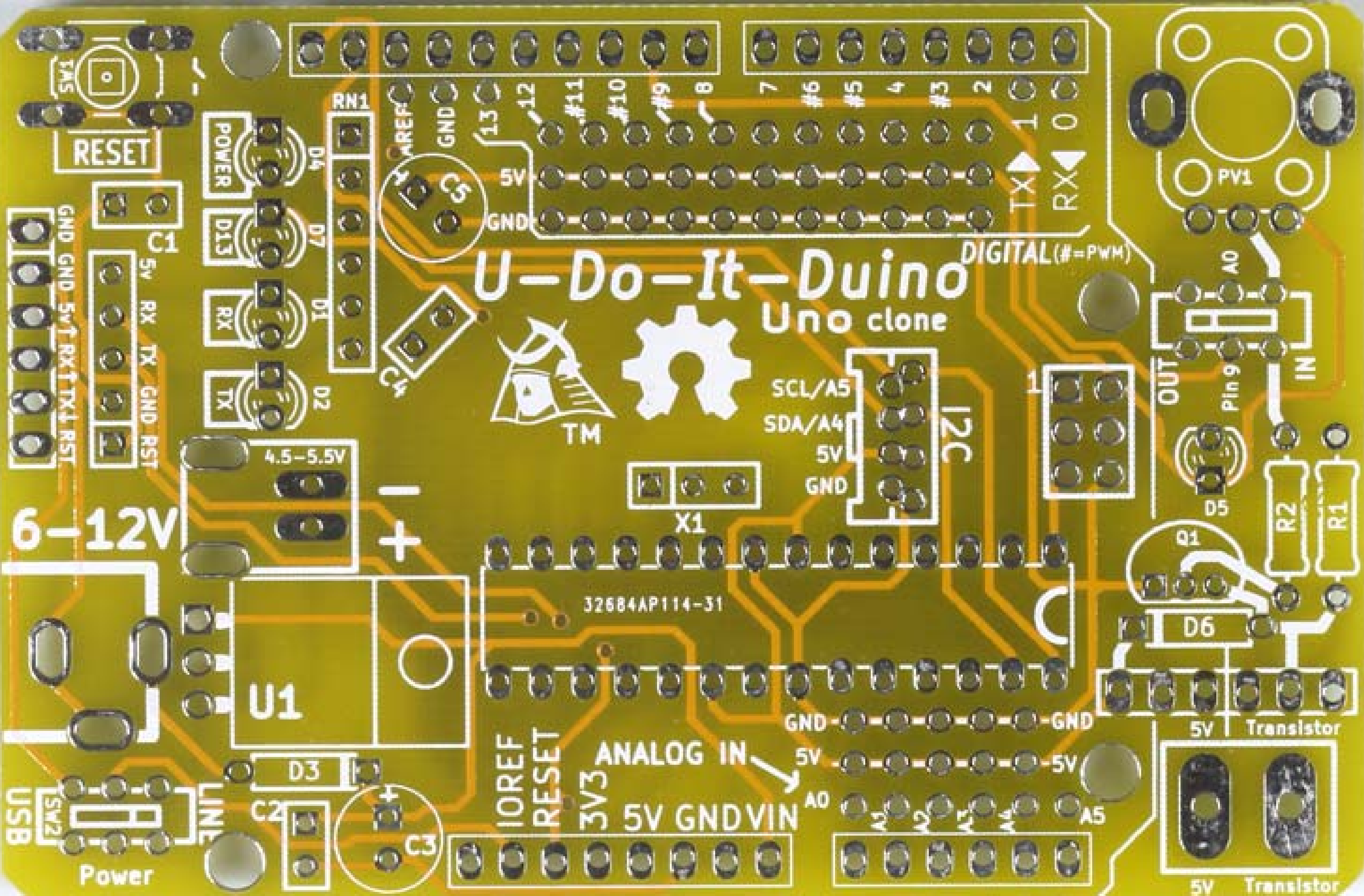

6-12V

Power

USB

RESET

POWER

D13

RX

TX

U1

D3

C2

LINE

RN1

D4

D7

D1

D2

4.5-5.5V

+

U1

D3

C2

LINE

AREF

GND

5V

GND

13

12

#11

#10

#9

8

7

#6

#5

#4

#3

2

1

TX

RX

0

0

DIGITAL (#=PWM)

PV1

A0

OUT

IN

Pin 6

Pin 9

R2

R1

D5

D6

5V

Transistor

5V

Transistor

SCL/A5

SDA/A4

5V

GND

I2C

X1

32684AP114-31

IOREF

RESET

3V3

5V

GND

VIN

A0

A5

A0

A5

A0

A5

A0

A5

A0

A5

A0

A0

A5

A0

A5

A0

A5

A0

A5

A0

A5

A0

A5

A0

A5

A0

A5

A0

A5

A0

A5

A0

A5

A0

A5

A0

A5

A0

A5

A0

A5

A0

A5

A0

A5

A0

A5

A0

A5

A0

A5

A0

A5

A0

A5

A0

A5

A0

A5

A0

A5

A0

A5

A0

A5

A0

A5

A0

A5

A0

A5

A0

A5

A0

A5

A0

A5

A0

A5

A0

A5

A0

A5

A0

A5

A0

A5

A0

A5

A0

A5

A0

A5

A0

A5

A0

A5

A0

A5

A0

A5

A0

A5

A0

A5

A0

A5

A0

A5

A0

A5

A0

A5

A0

A5

A0

A5

A0

A5

A0

A5

A0

A5

A0

A5

A0

A5

A0

A5

A0

A5

A0

A5

A0

A5

A0

A5

A0

A5

A0

A5

A0

A5

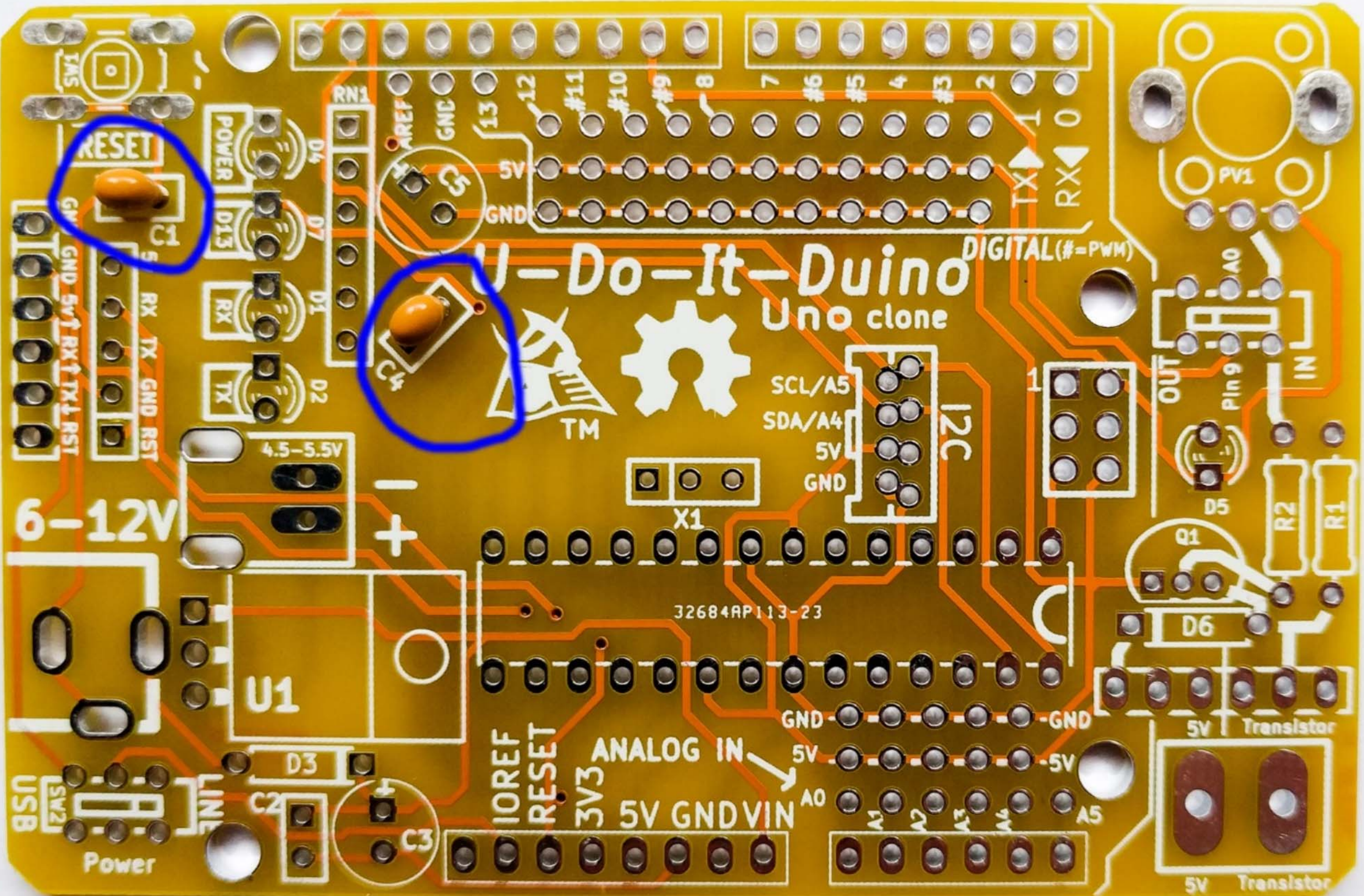

U-Do-It-Duino Uno clone



32684AP113-23

DIGITAL (#=PWM)

6-12V

I2C

U1

X1

ANALOG IN

Q1

USB

Power

C2

D3

C3

D6

5V Transistor

5V Transistor

RESET

POWER

RX

TX

4.5-5.5V

IOREF
RESET
3V3
5V GND VIN

GND 5V -5V

SCL/A5
SDA/A4
5V
GND

PV1

A0

IN

OUT

Pin 9

D5

5V

5MS

GND 5V TX RX TX↑ RX↓ TX↑ RST

GND 5V TX RX TX↑ RX↓ TX↑ RST

GND 5V TX RX TX↑ RX↓ TX↑ RST

GND 5V TX RX TX↑ RX↓ TX↑ RST

GND 5V TX RX TX↑ RX↓ TX↑ RST

GND 5V TX RX TX↑ RX↓ TX↑ RST

GND 5V TX RX TX↑ RX↓ TX↑ RST

GND 5V TX RX TX↑ RX↓ TX↑ RST

GND 5V TX RX TX↑ RX↓ TX↑ RST

GND 5V TX RX TX↑ RX↓ TX↑ RST

RN1

D4

D1

D2

D7

D8

D9

D10

D11

D12

AREF

5V

GND

13

12

#11

#10

#9

8

7

#6

#5

4

#3

2

1

TX

RX

0

1

2

3

4

5

A0

A1

A2

A3

A4

A5

A6

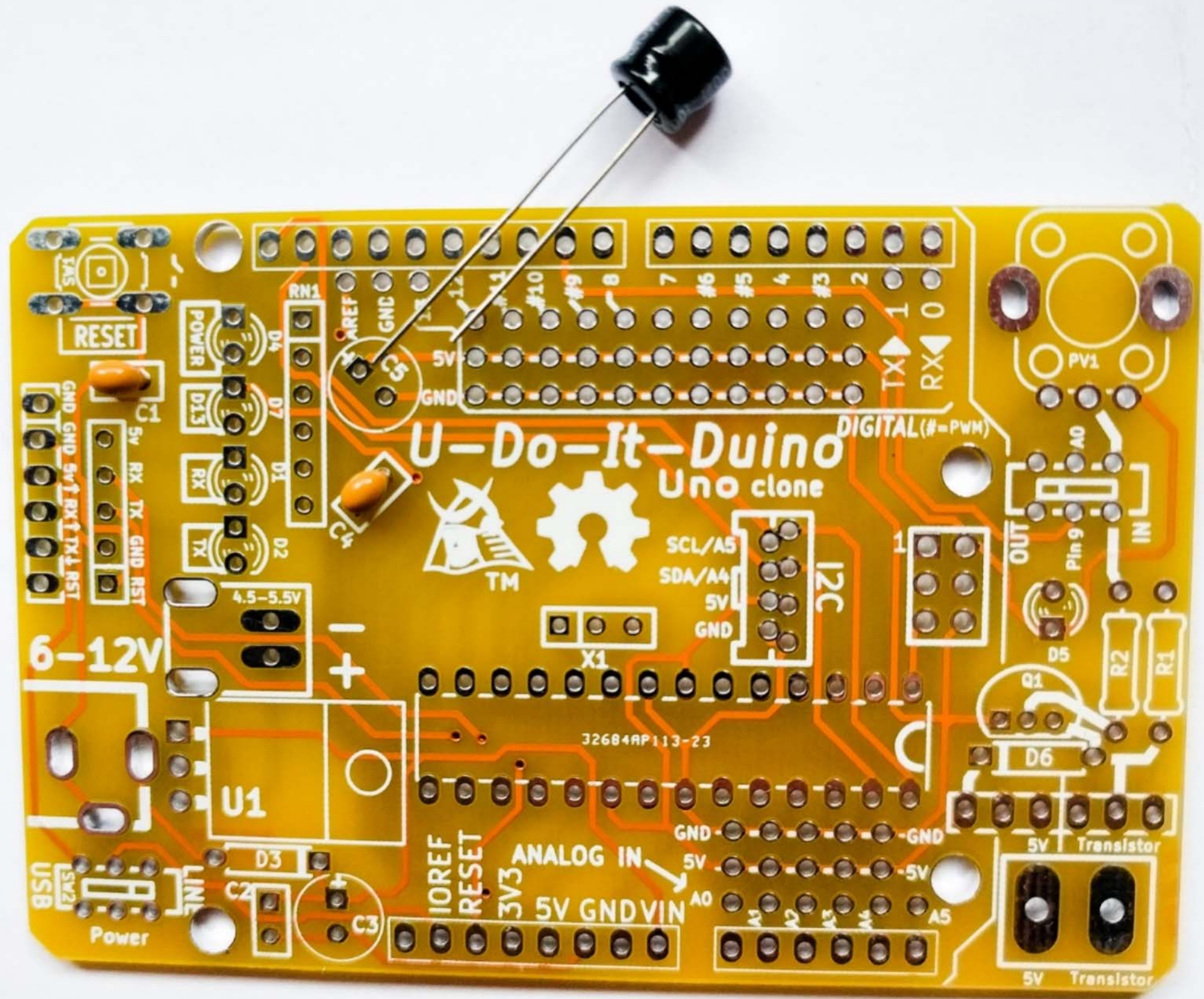

U-Do-It-Duino
Uno clone



6-12V

32684AP113-23

USB

Power

IOREF
RESET
3V3
5V GND VIN

ANALOG IN

DIGITAL (#=PWM)

I2C

5V Transistor

5V Transistor

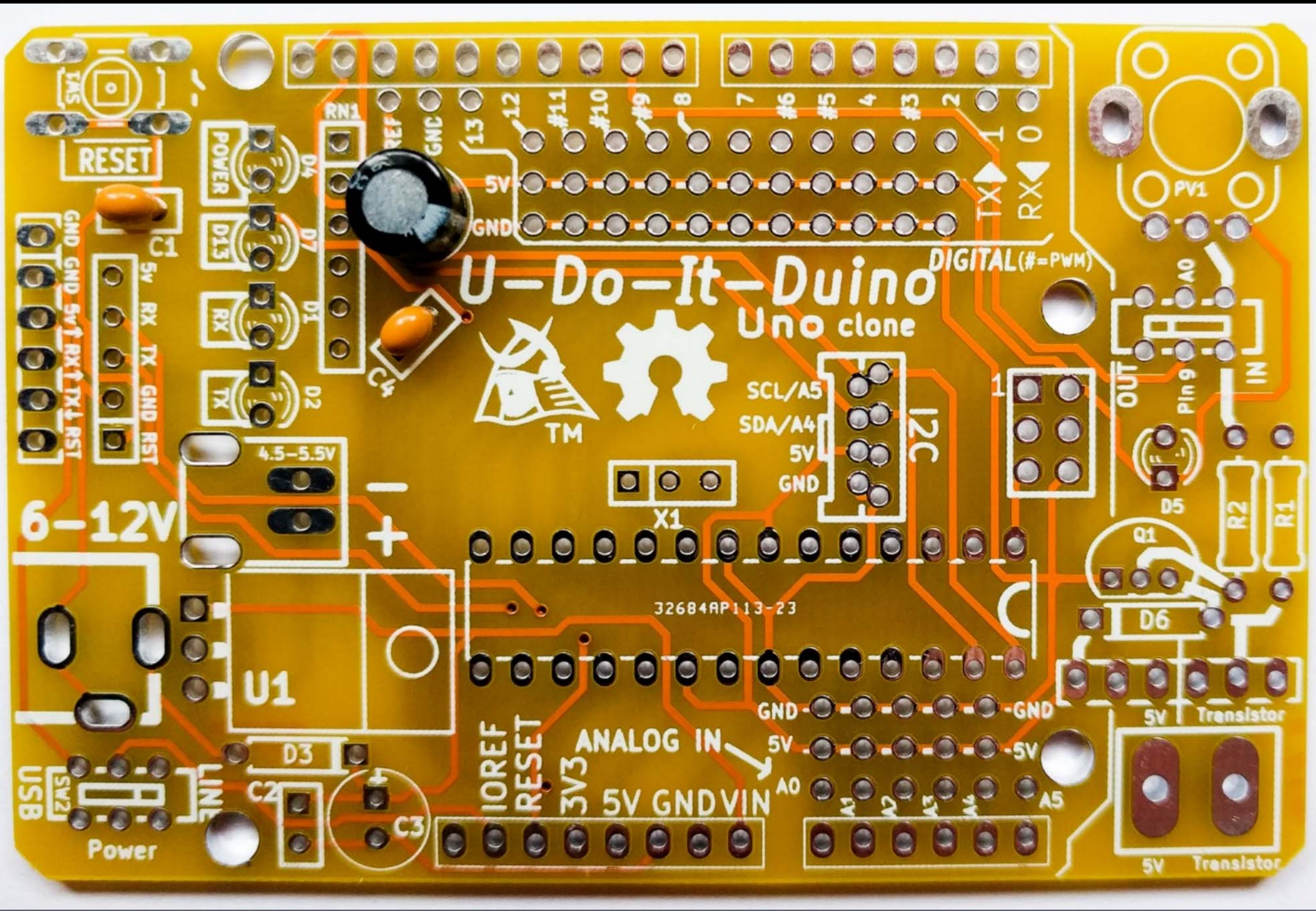

U-Do-It-Duino
Uno clone



32684AP113-23

Power
USB

POWER
D13
RX
TX
D4
D7
D1
D2

I2C
SCL/A5
SDA/A4
5V
GND

DIGITAL (#=PWM)

IOREF
RESET
3V3
5V
GND
VIN

ANALOG IN
A0
A1
A2
A3
A4
A5

5V Transistor
5V Transistor

Long lead

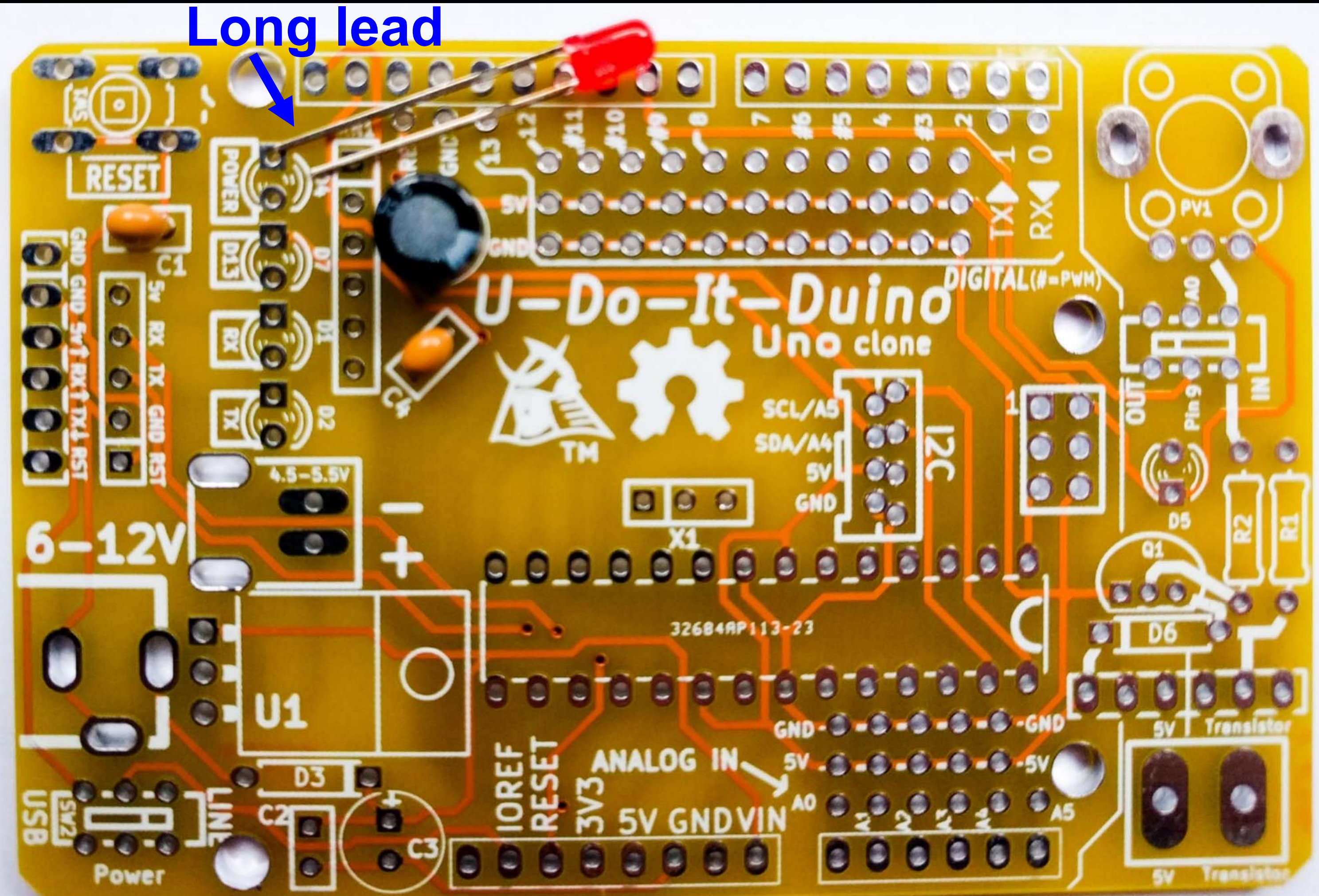

U-Do-It-Duino

Uno clone



32684AP113-23

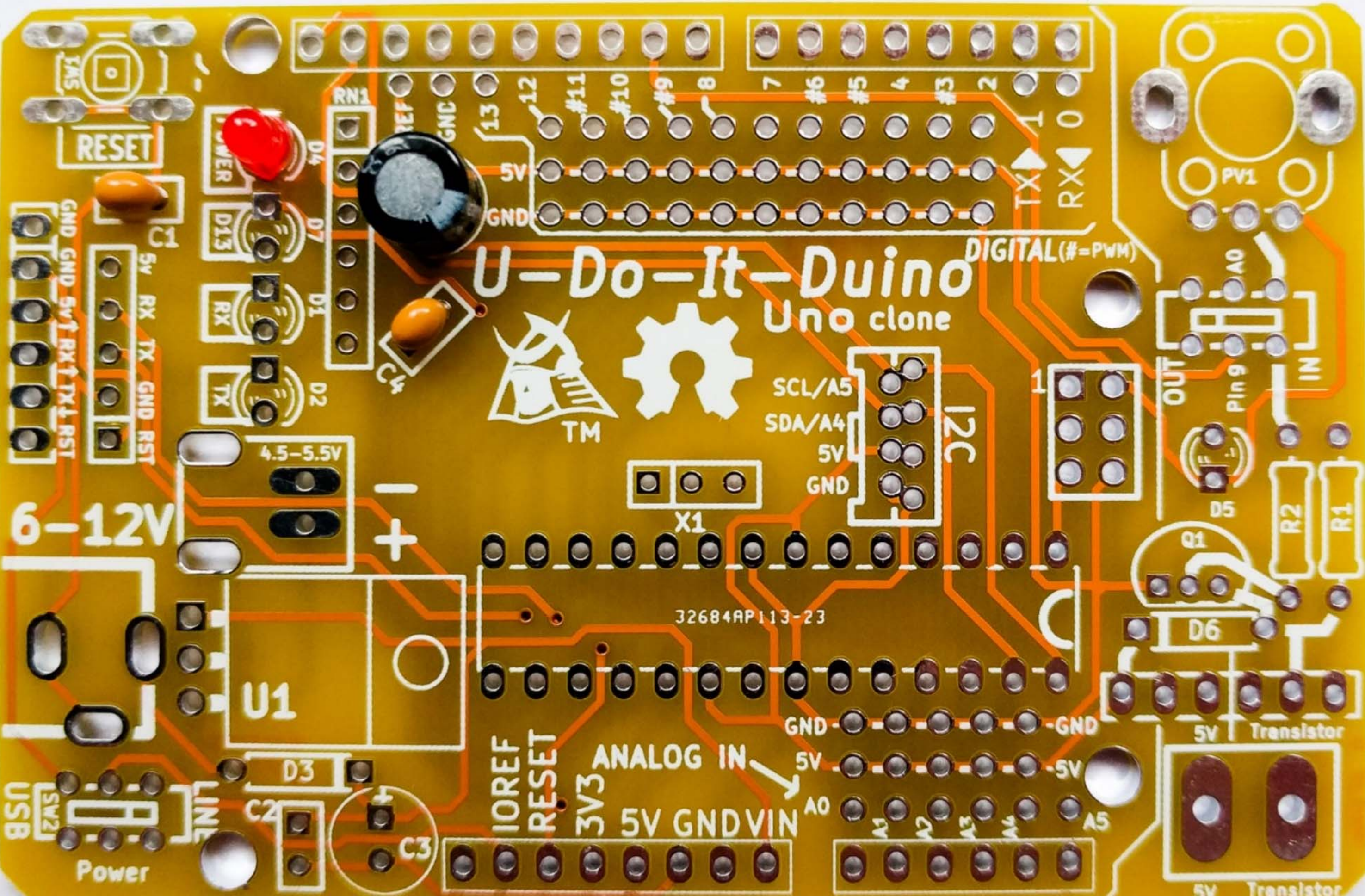

U-Do-It-Duino
Uno clone

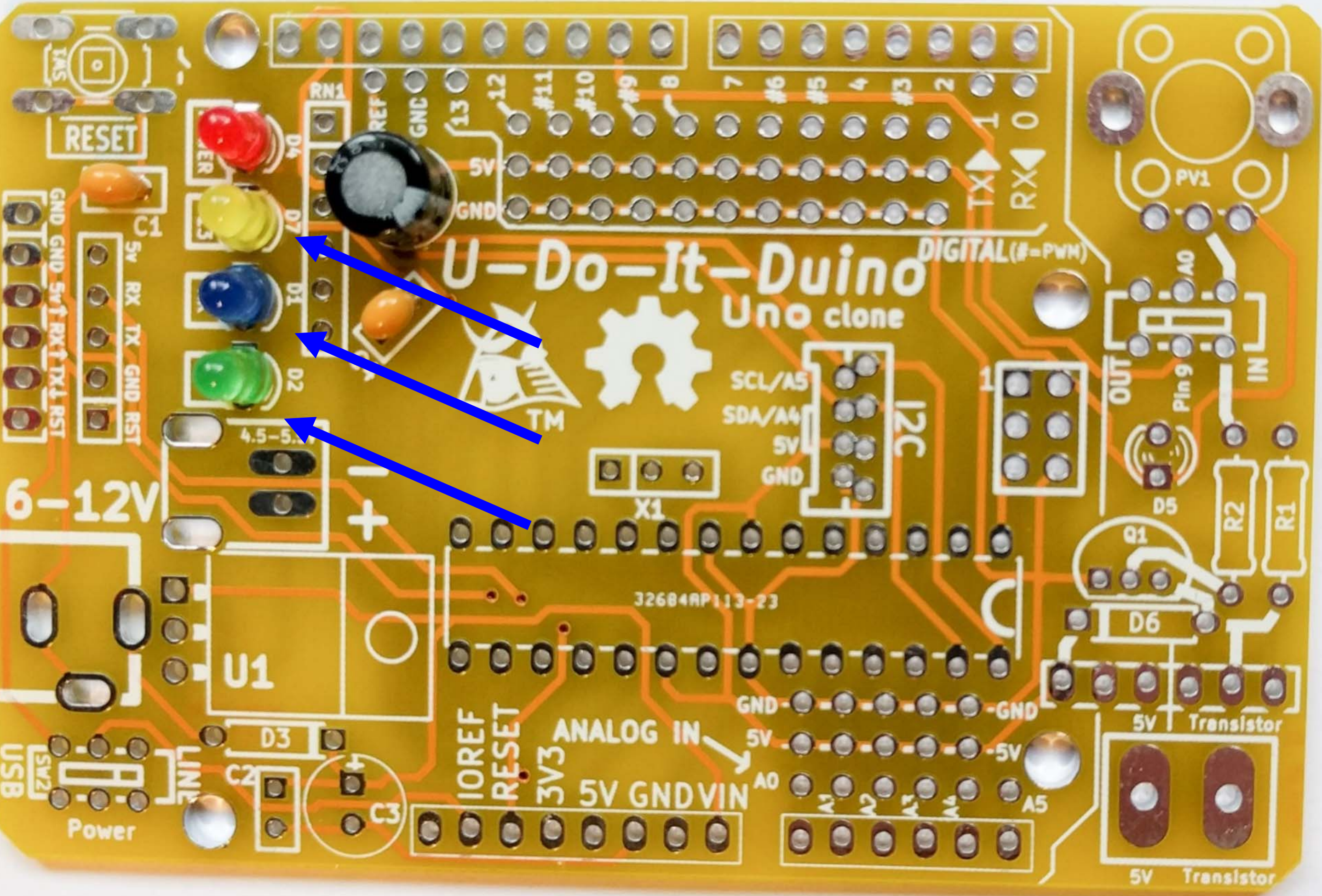

U-Do-It-Duino

Uno clone

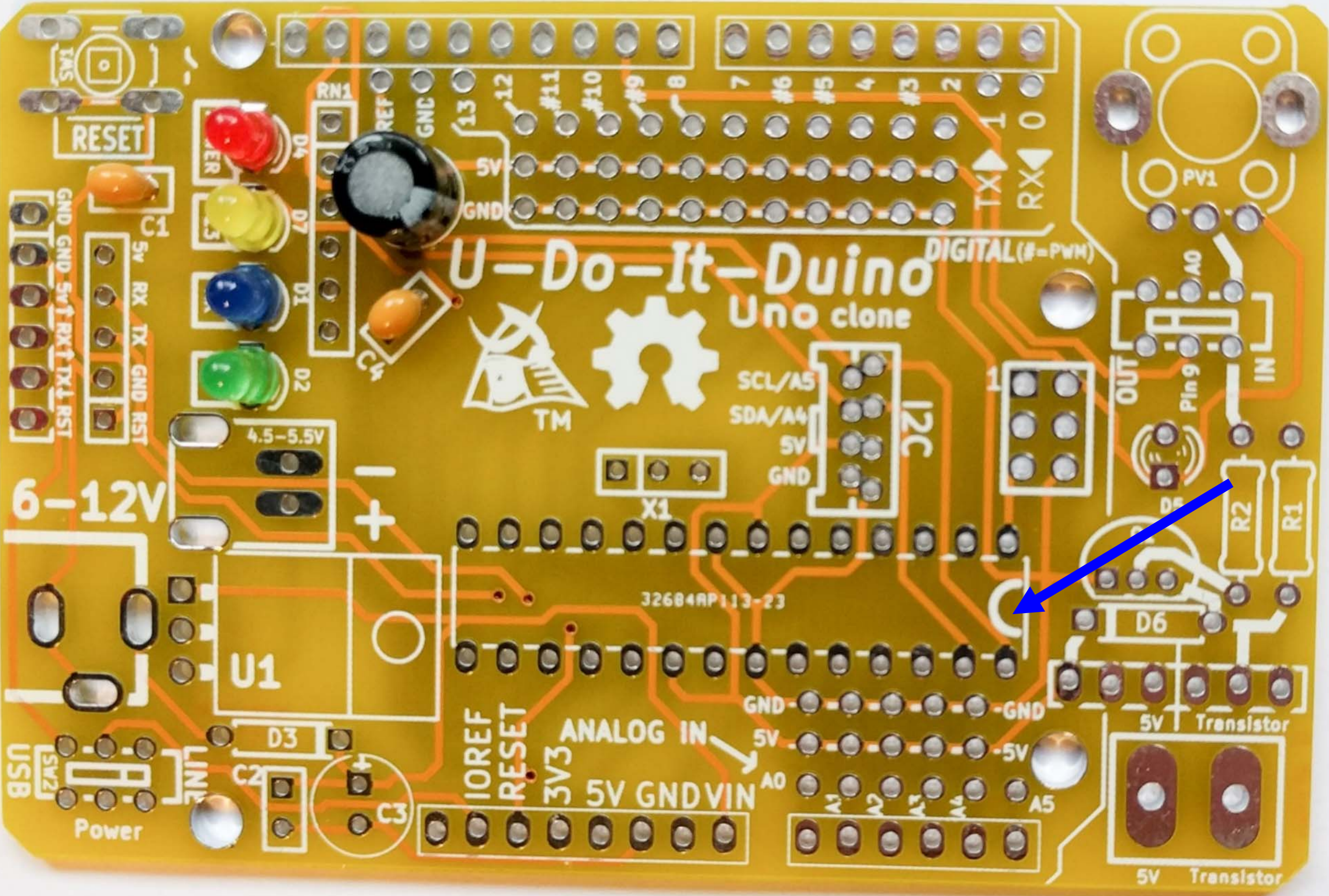



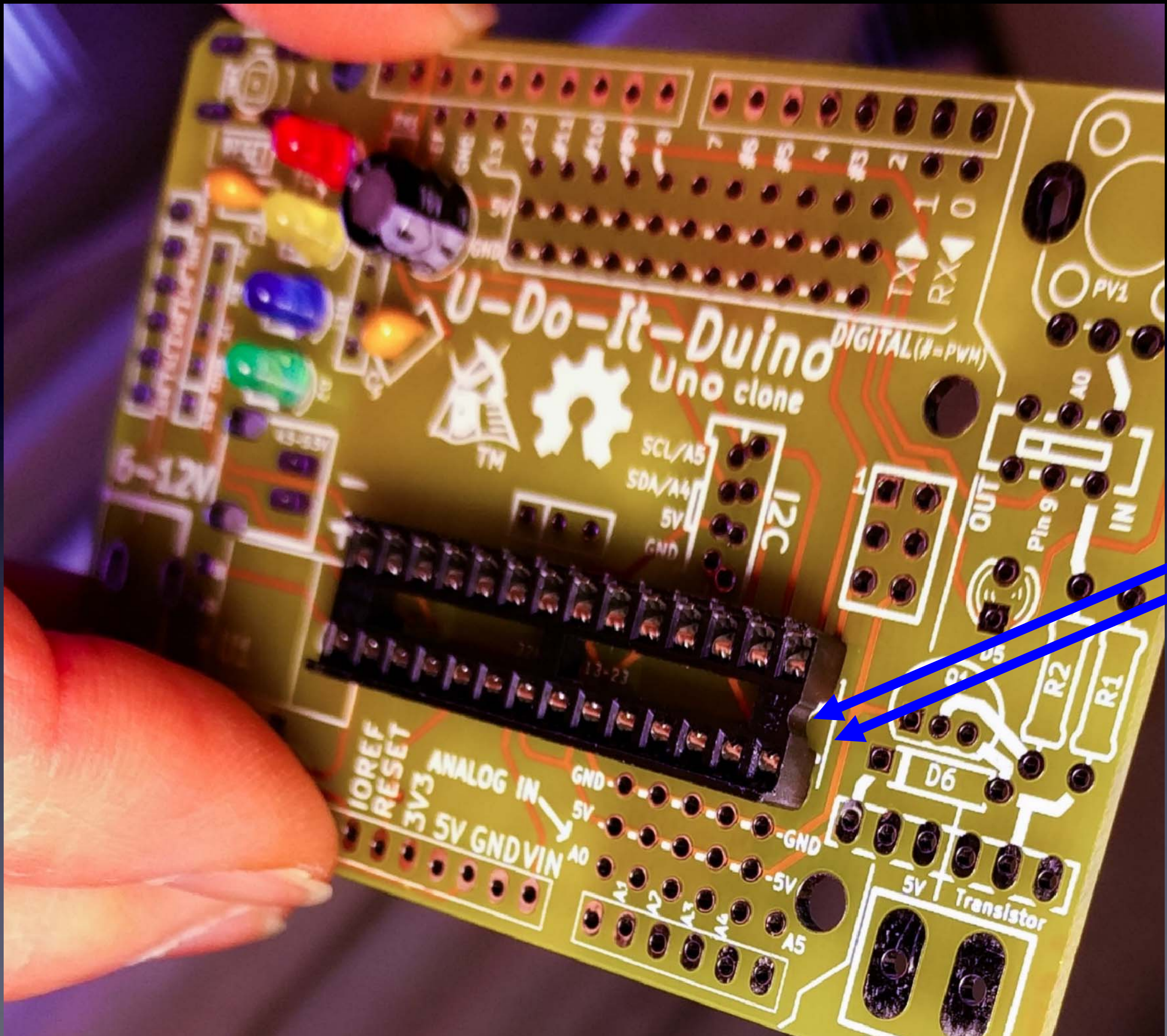

U-Do-It-Duino
Uno clone

DIGITAL (M-PWM)

SCL/A5
SDA/A4
5V
GND

I2C

IOREF
RESET
3V3
5V
ANALOG IN
GND
VIN
A0

OUT

Pin 9

IN

D6

R2

R1

5V

Transistor

-5V

A5

Bend pins down on two opposite corners



- Solder all 28 pins.
- Only need to clean the tip after it gets dirty.
- No need to cut the pins short after soldering.

U-Do-It-Duino

Uno clone

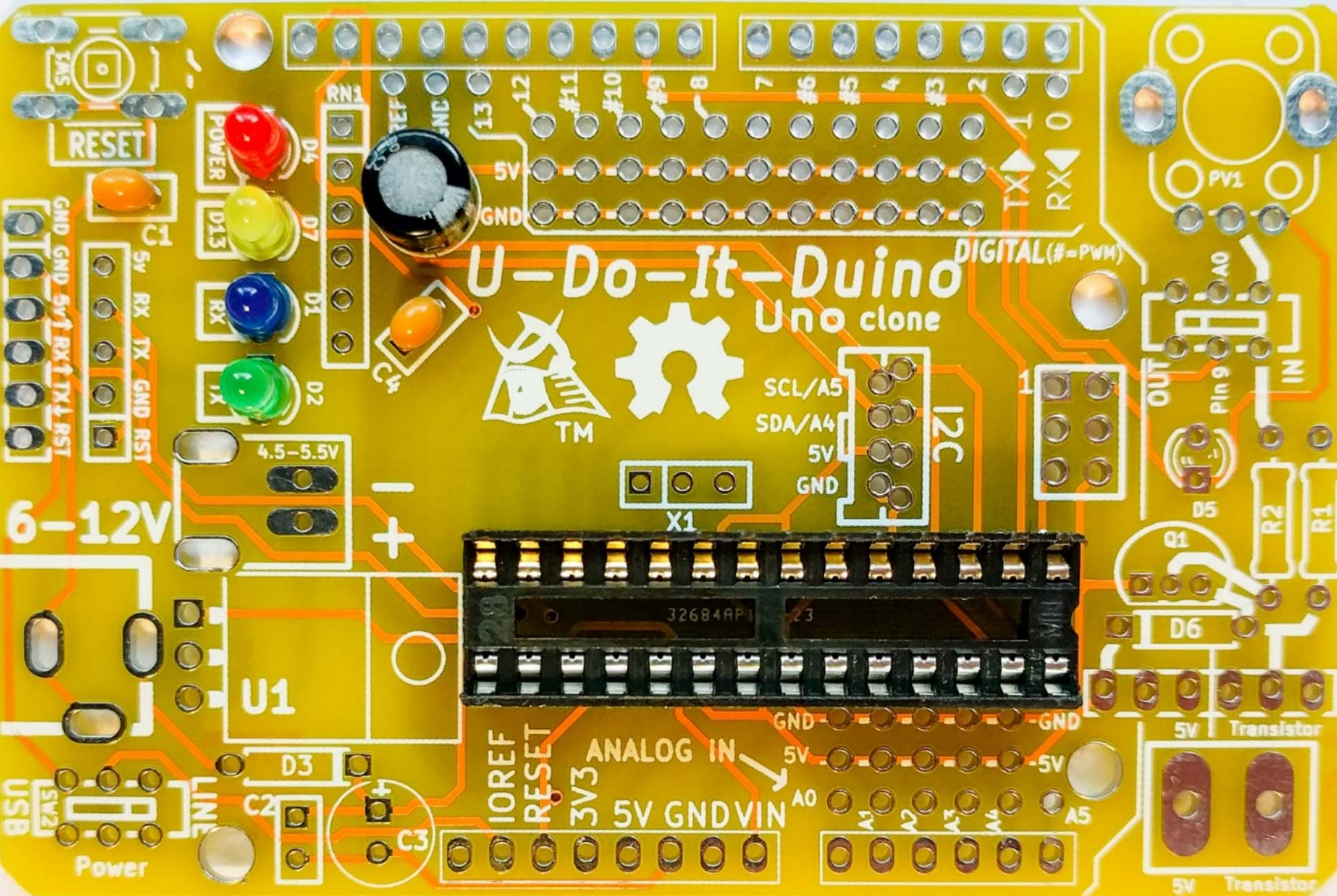
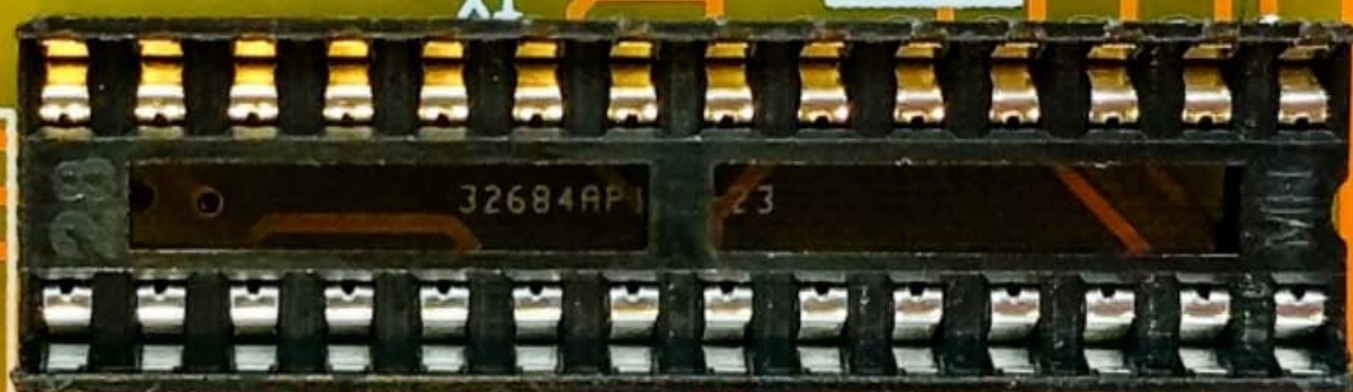

6-12V

RESET

U-Do-It-Duino

Uno clone

DIGITAL (#=PWM)

SCL/A5
SDA/A4
5V
GND

I2C

X1

U1

USB

Power

IOREF
RESET

3V3
5V GND VIN

ANALOG IN

GND 5V -5V

A0

A5

5V Transistor

5V Transistor

PV1

A0

OUT

Pin 9

IN

R1

R2

D6

5V

Transistor

5V

Transistor

4.5-5.5V

POWER

ID13

RX

TX

RN1

D4

D7

D1

D2

D3

C2

C3

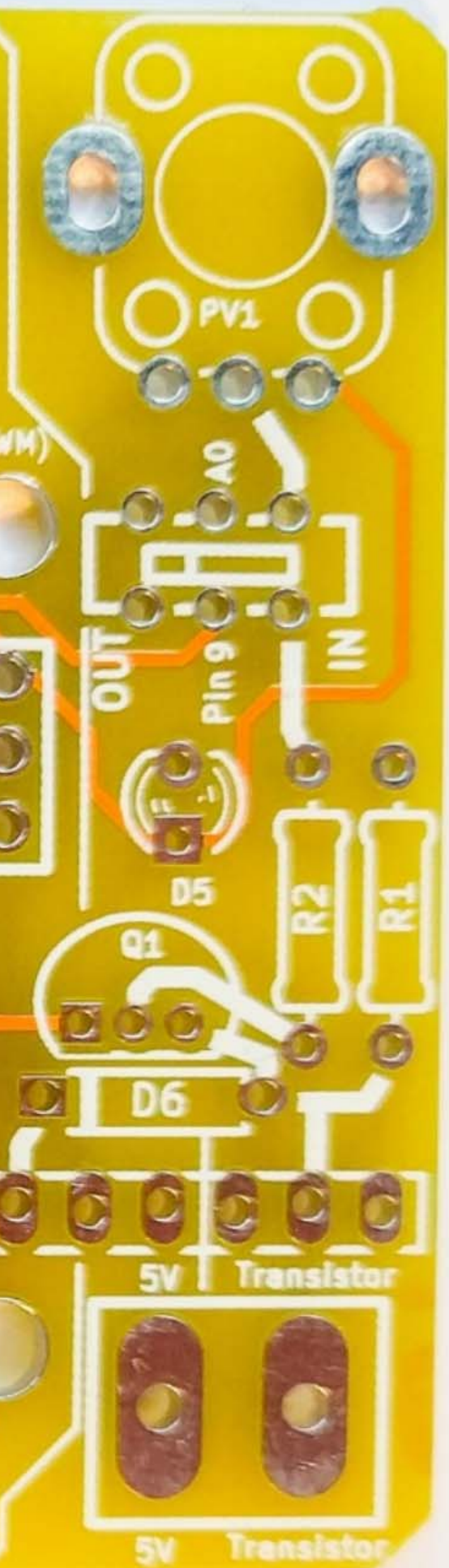
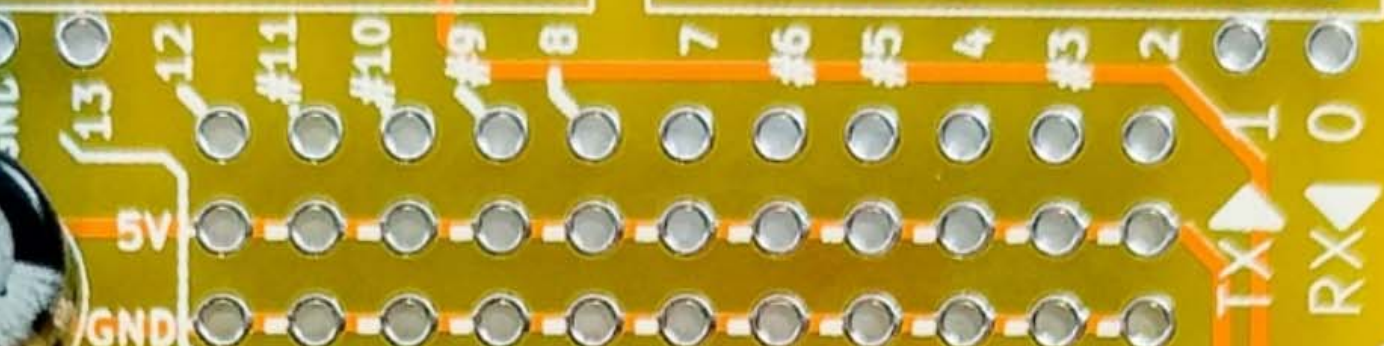

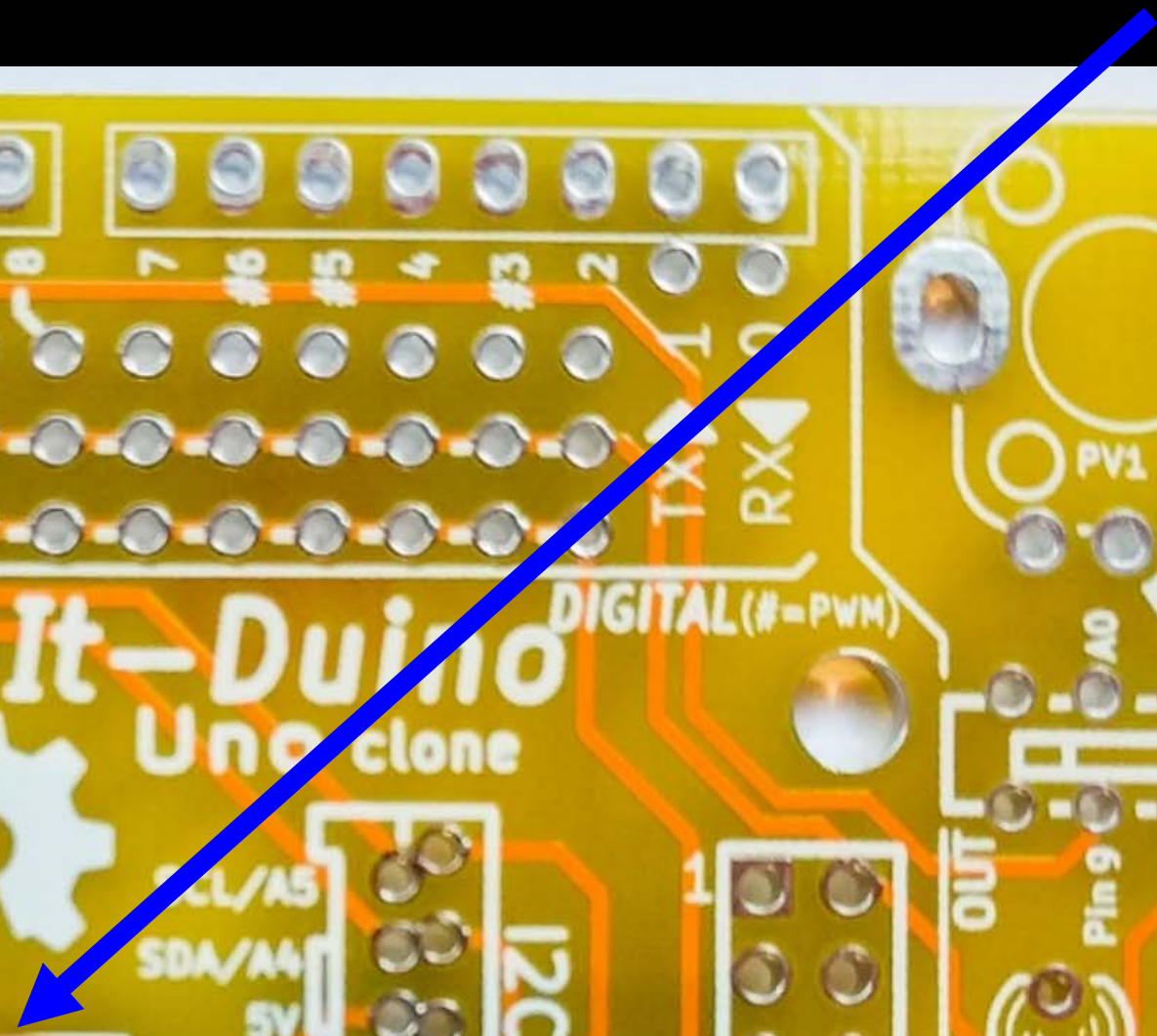
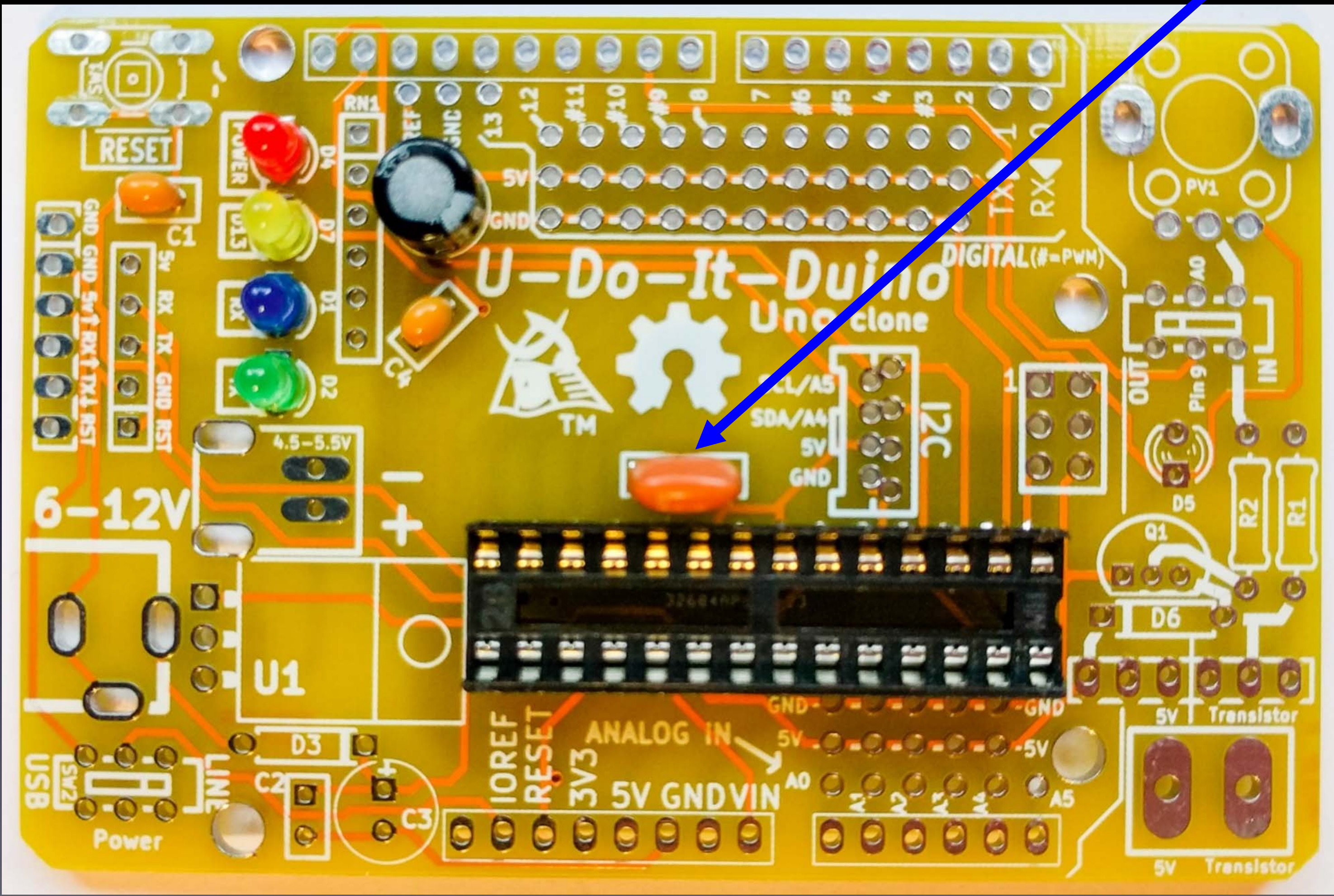

Solder on top of board if it falls out upside down

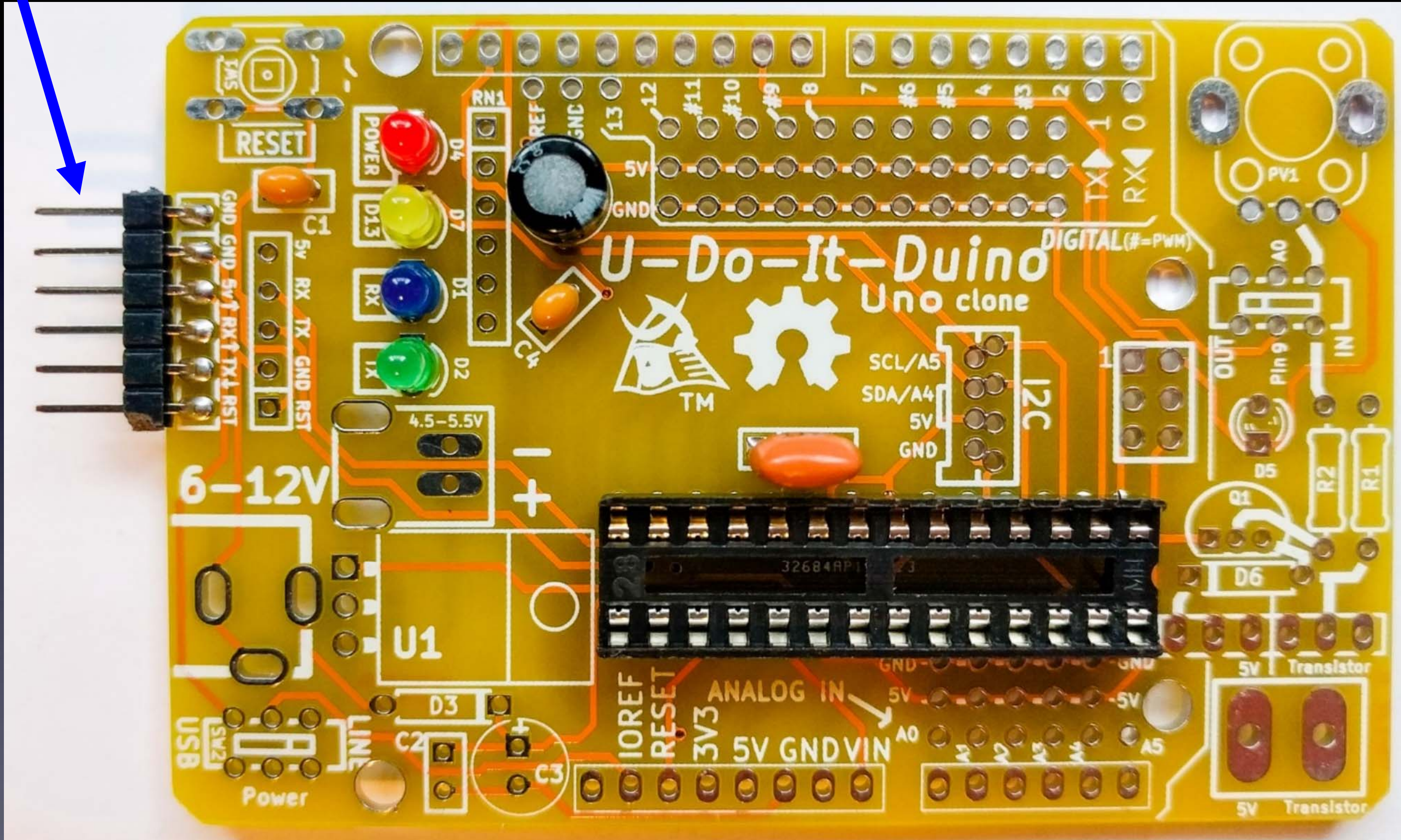

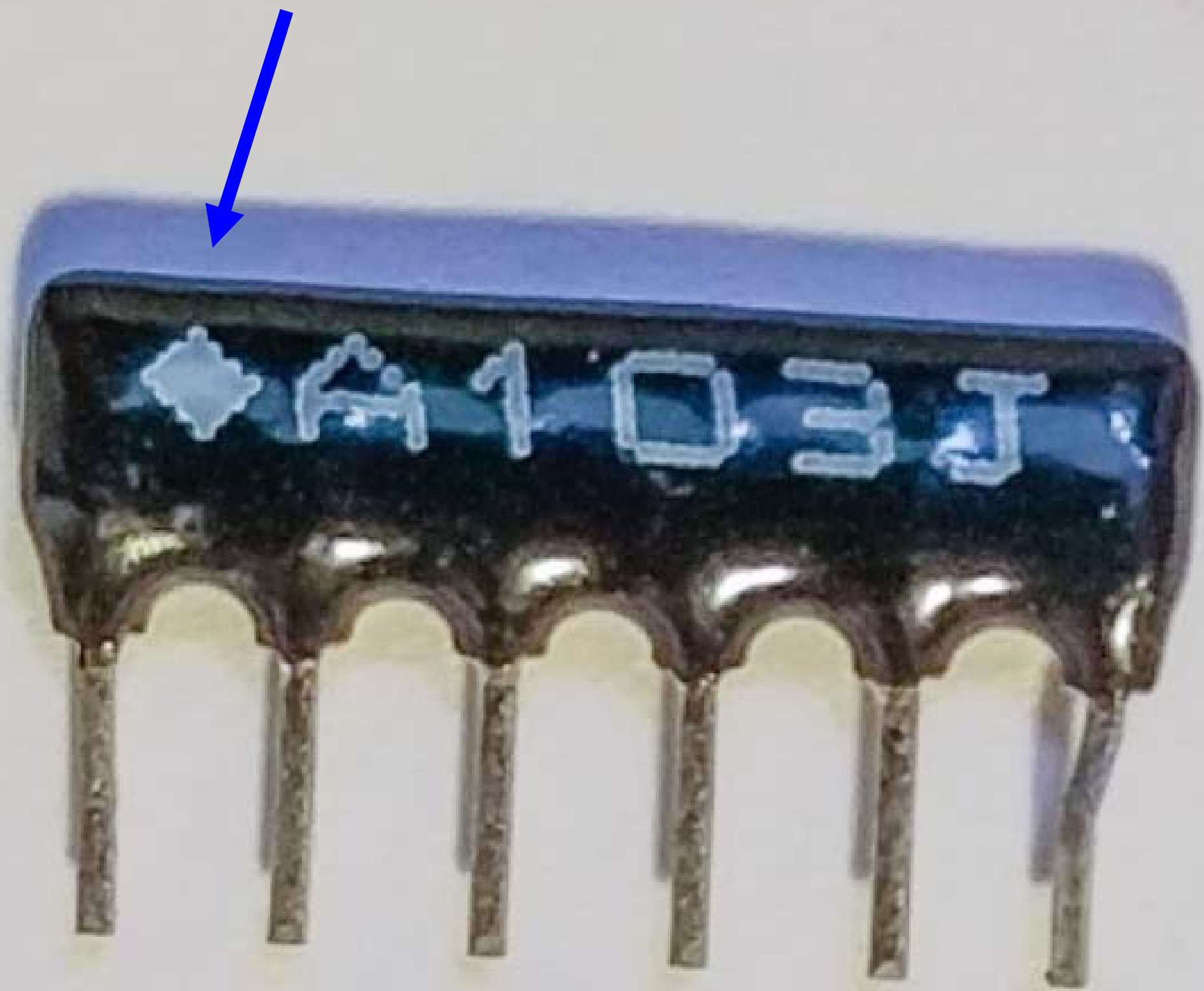

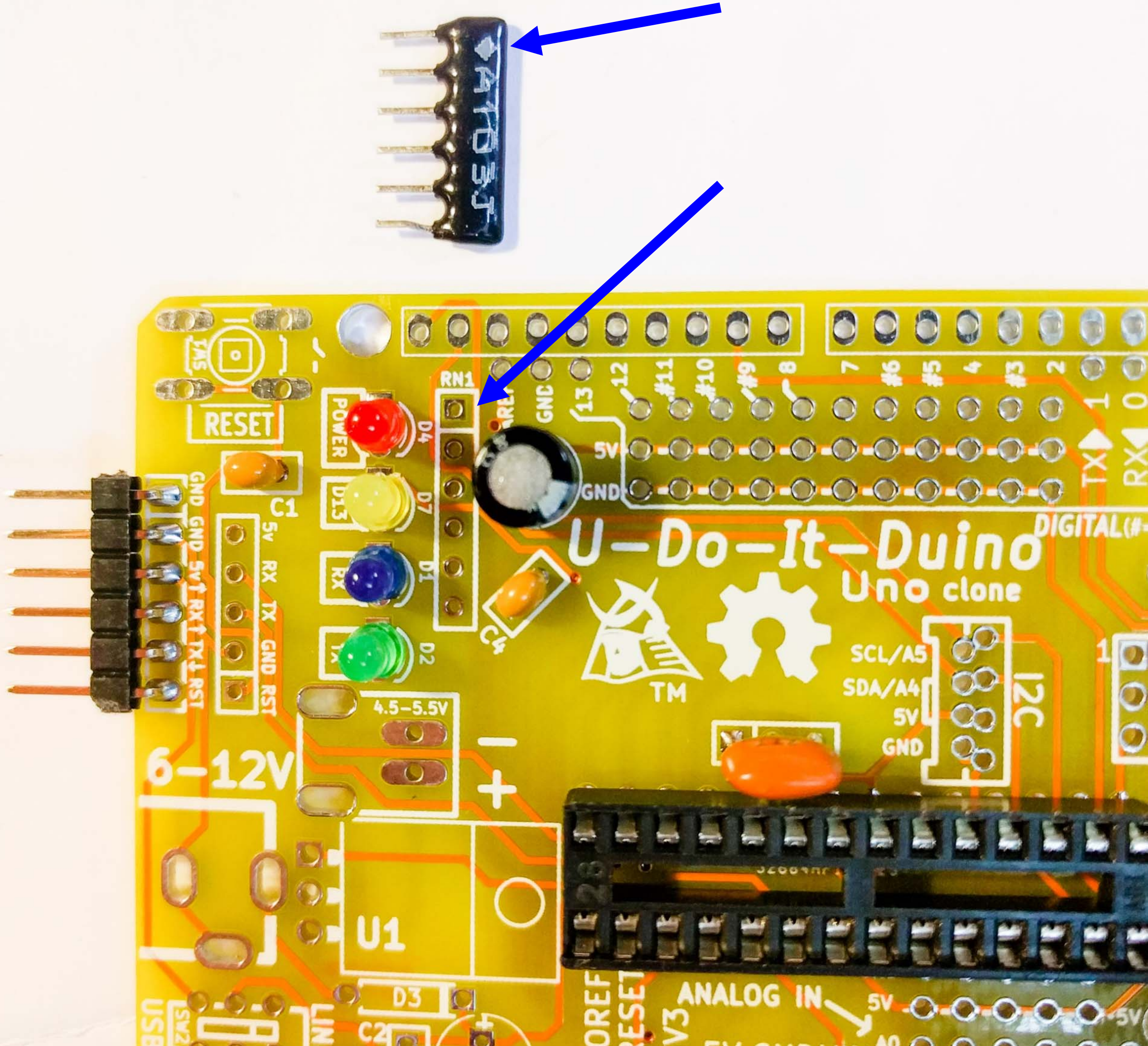

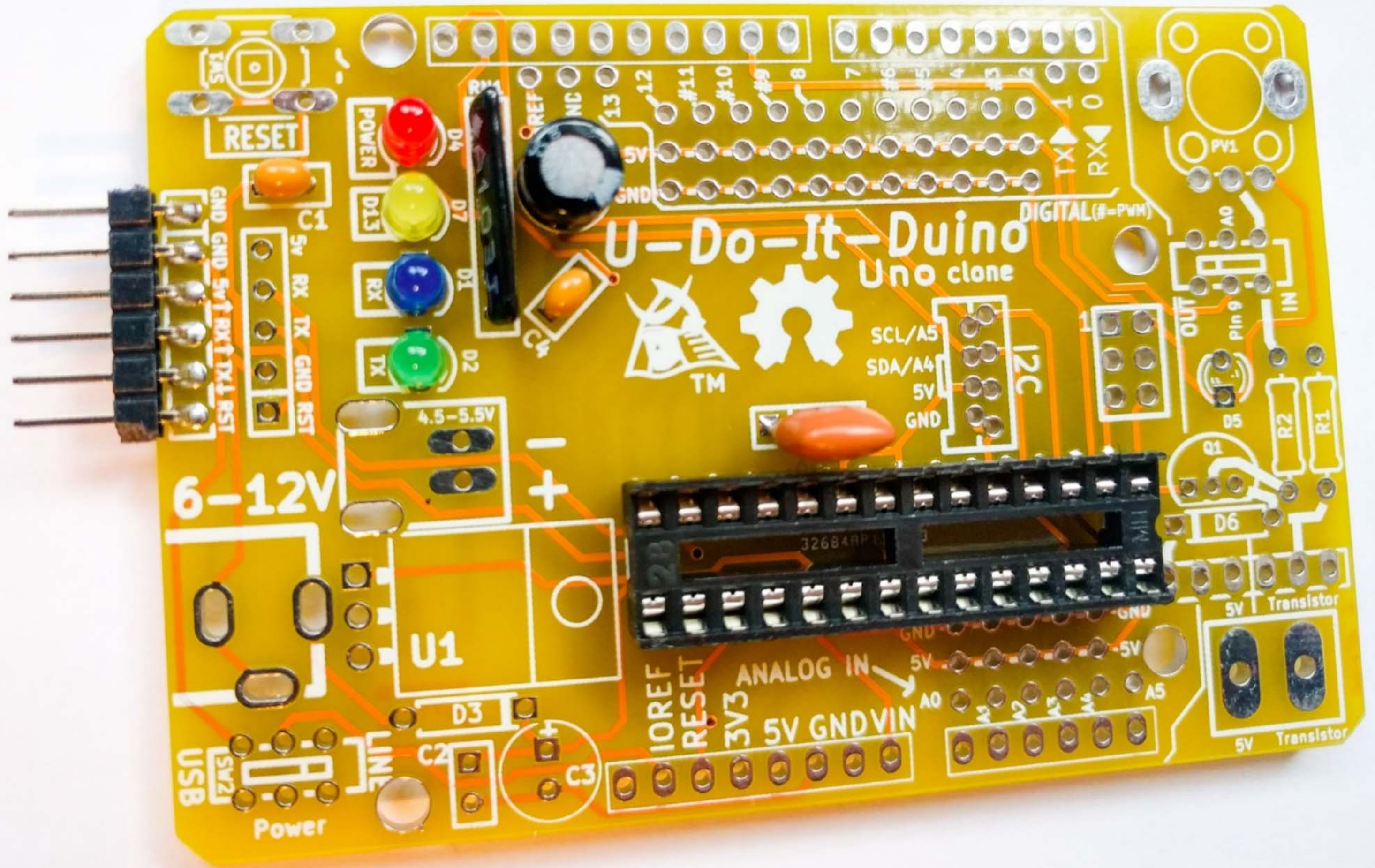

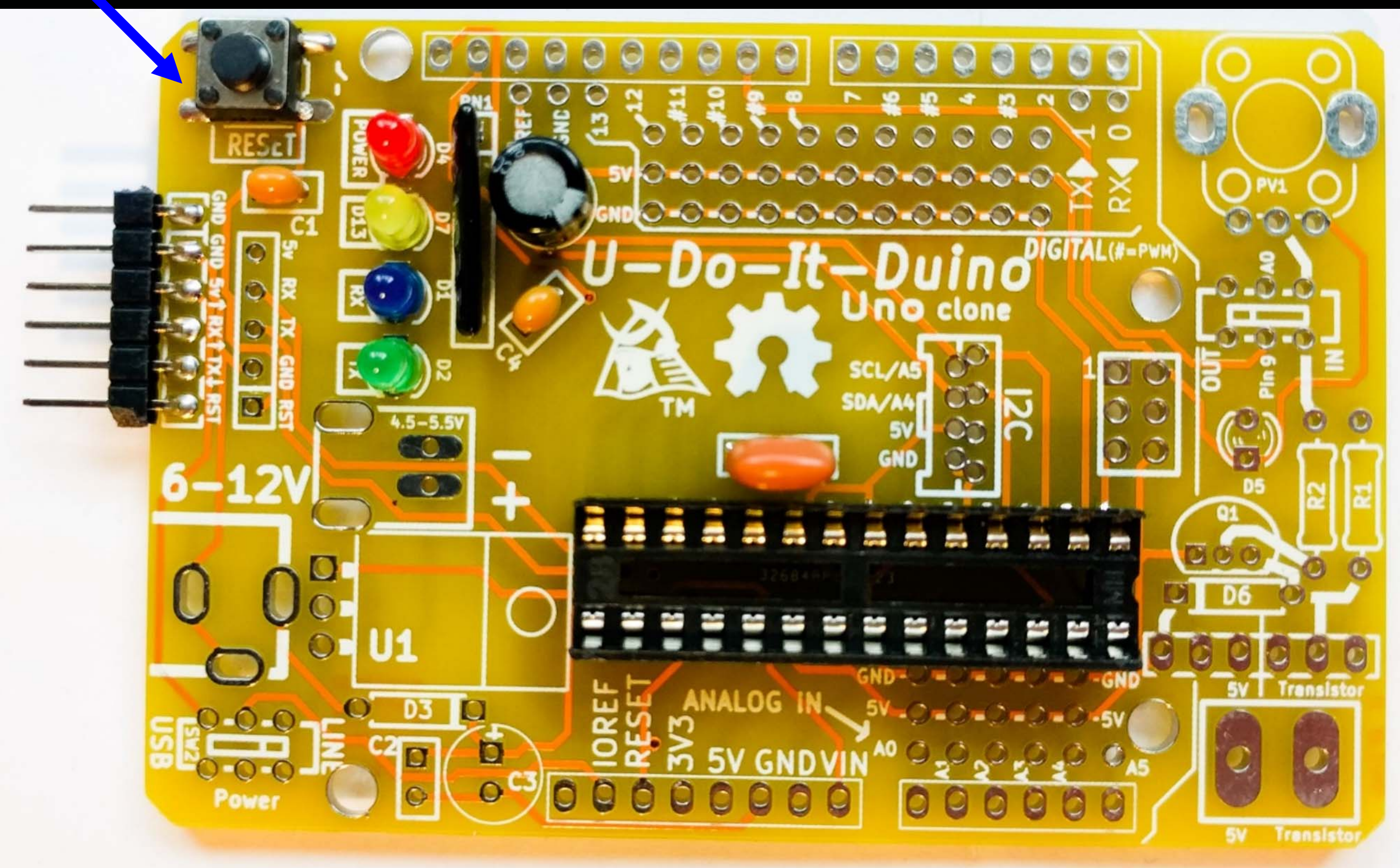
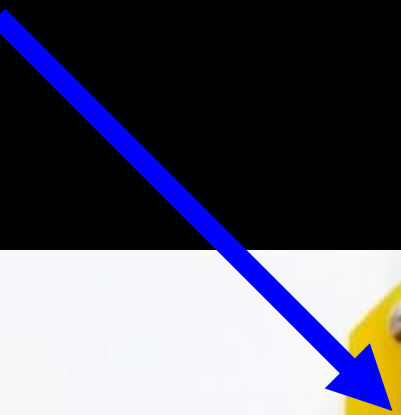

Headers

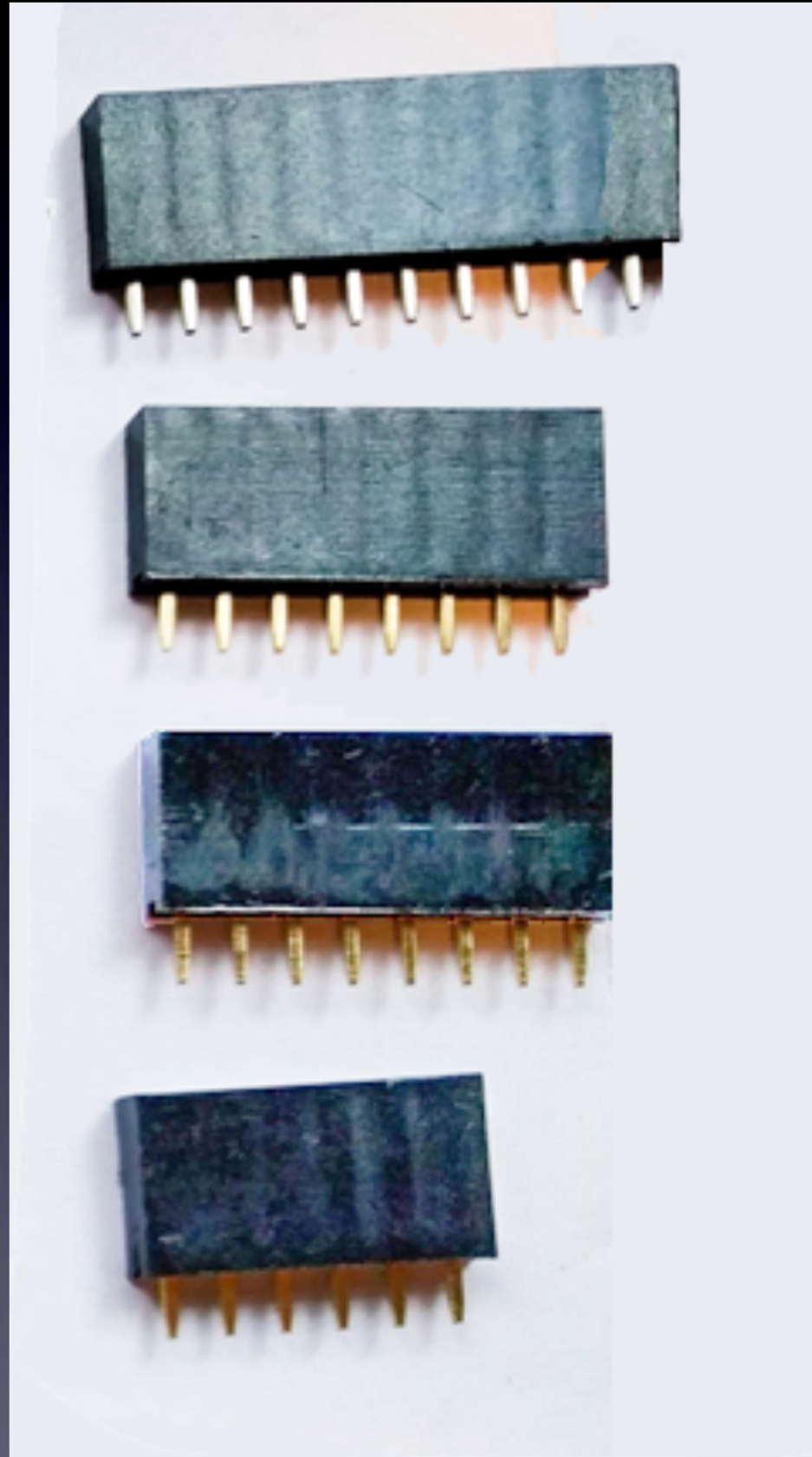

Headers

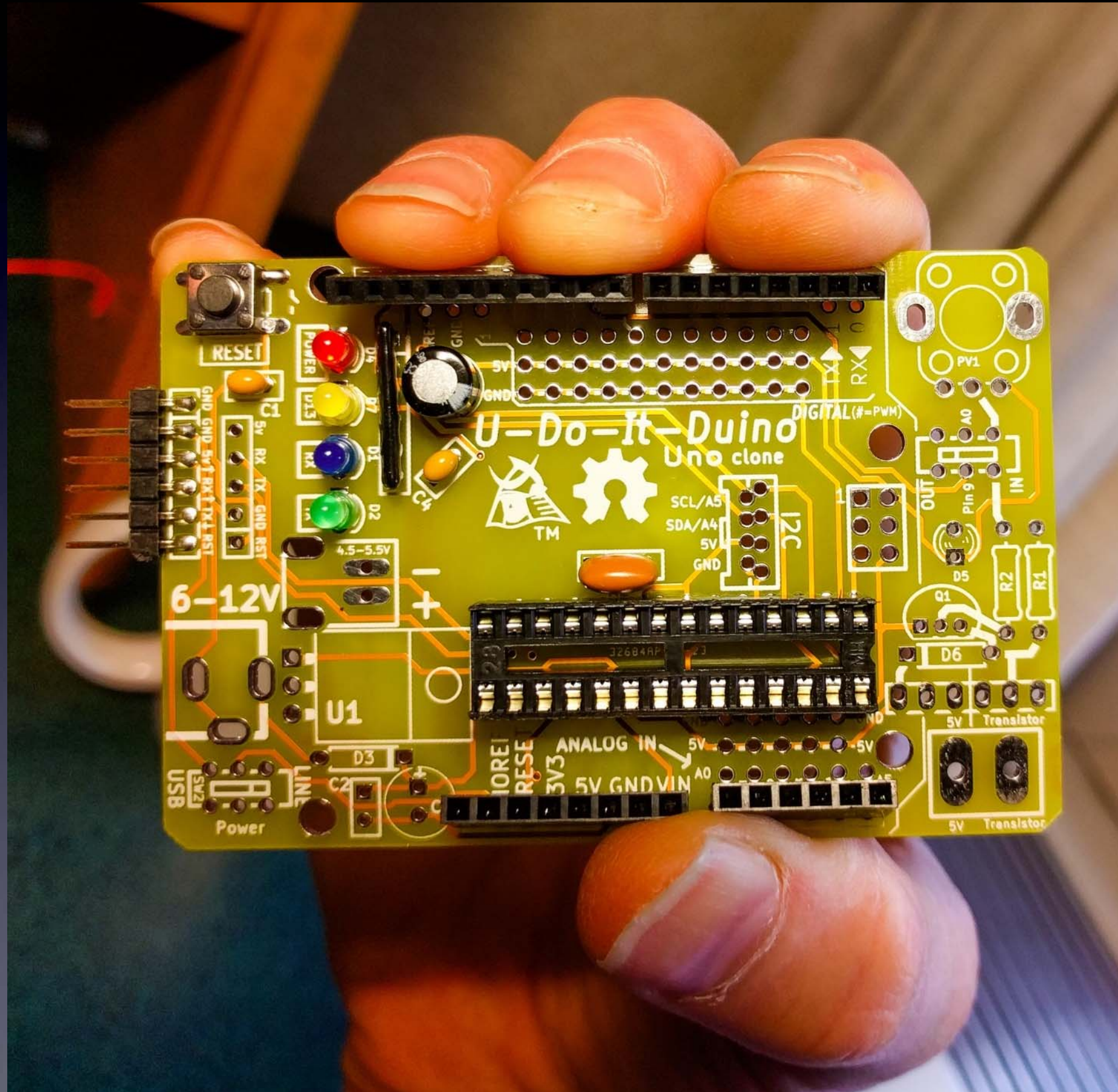

Headers

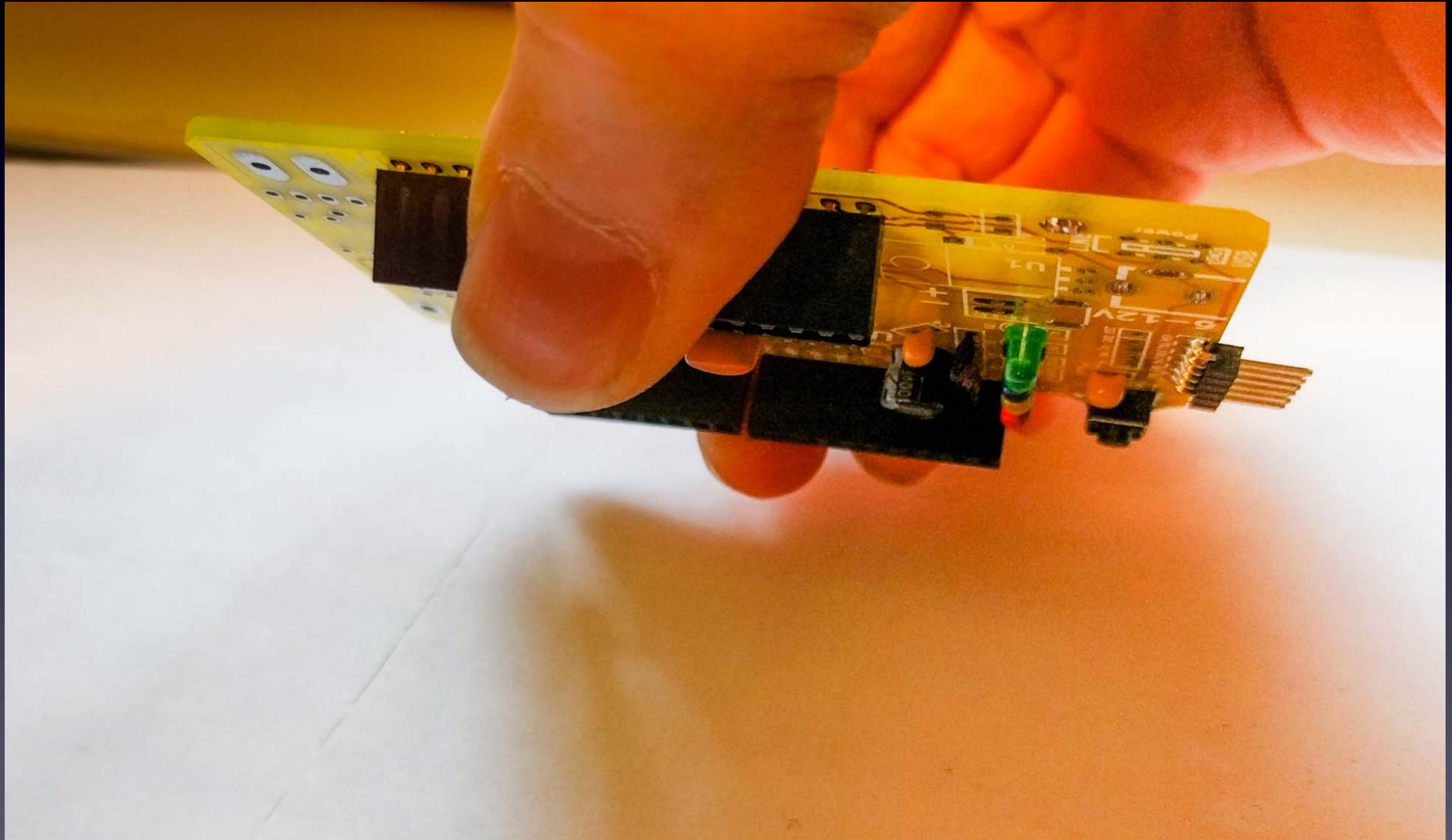

Headers

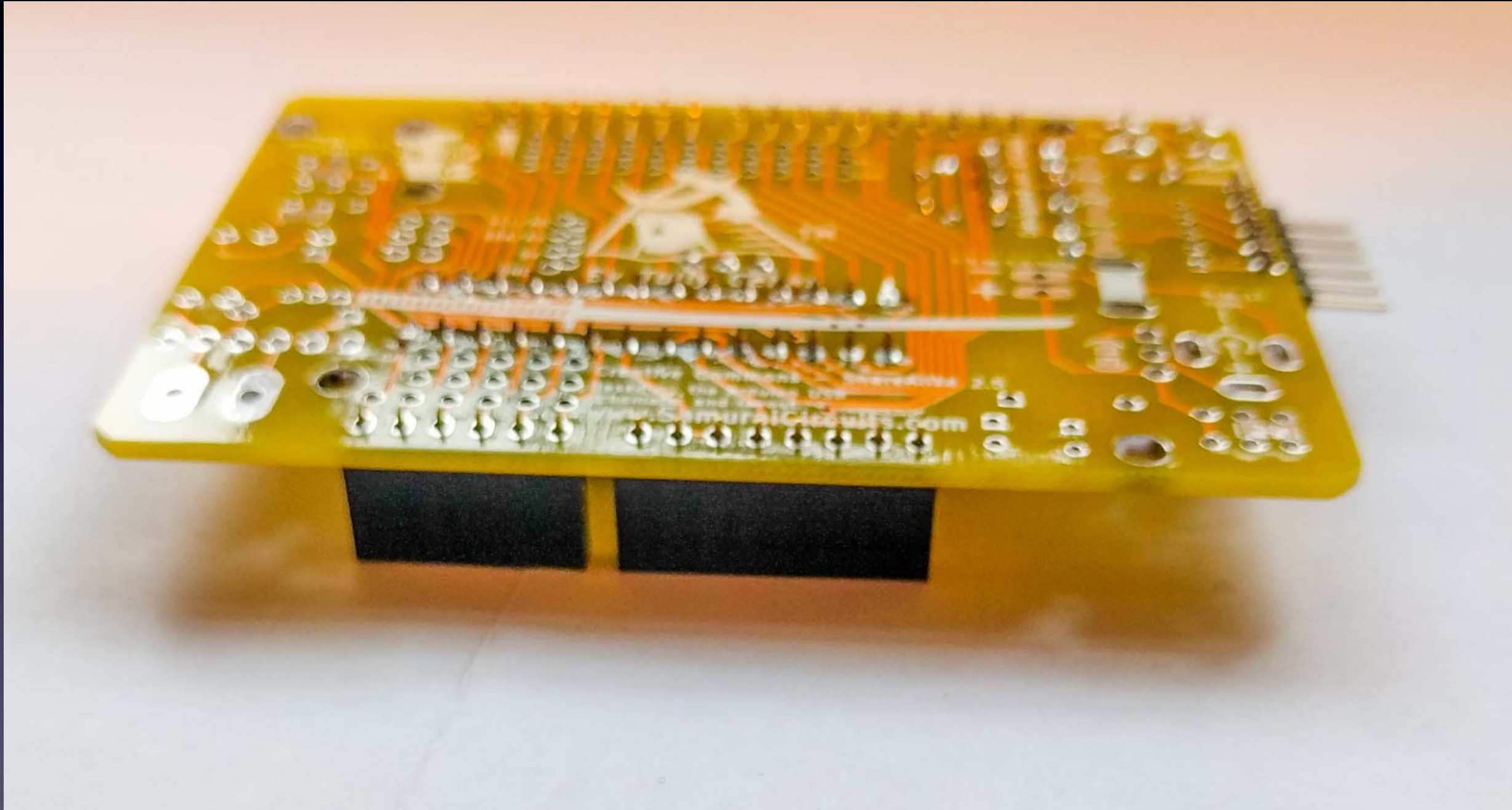

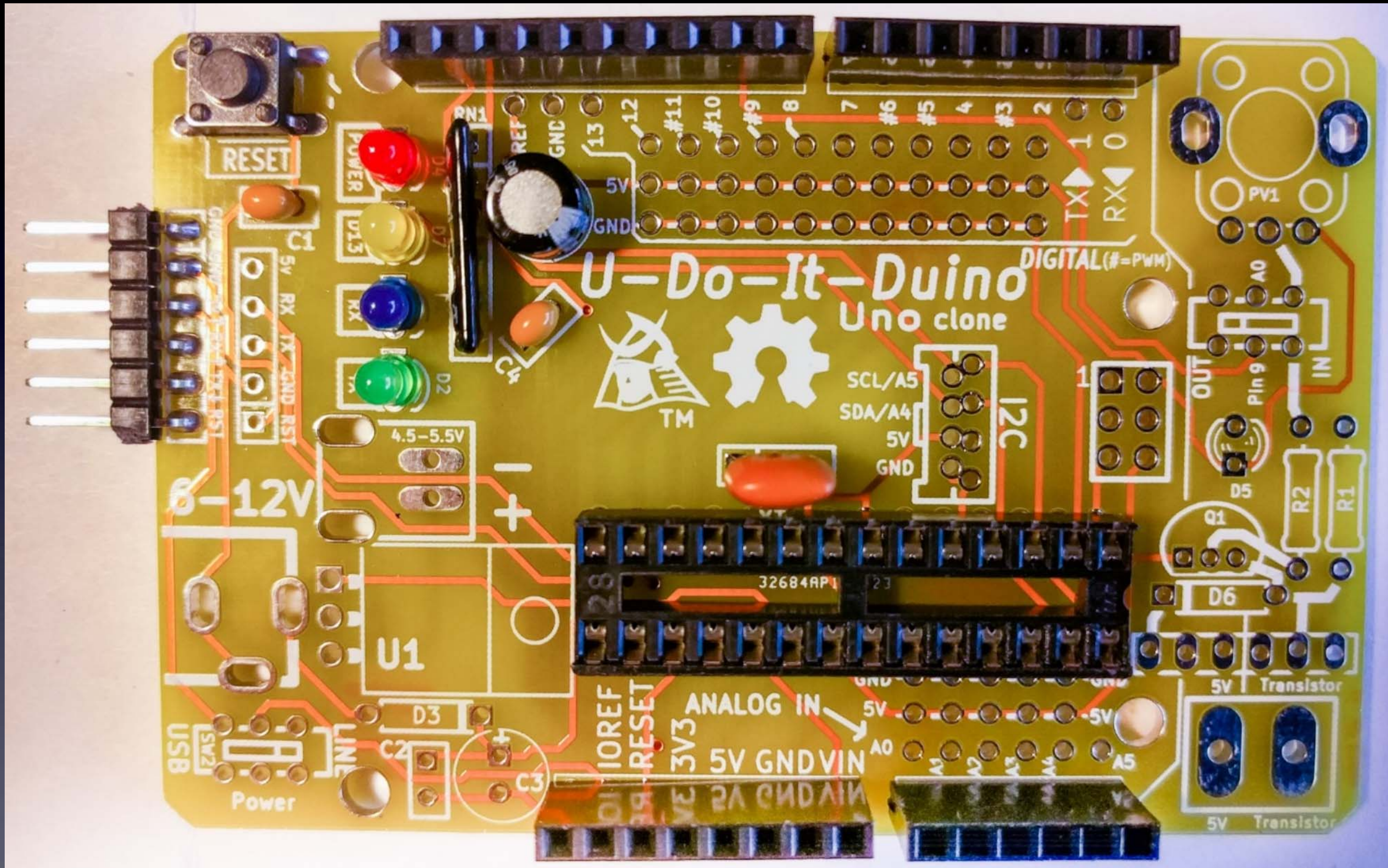



A82448
35473D
1-P1549 E3

30 pins

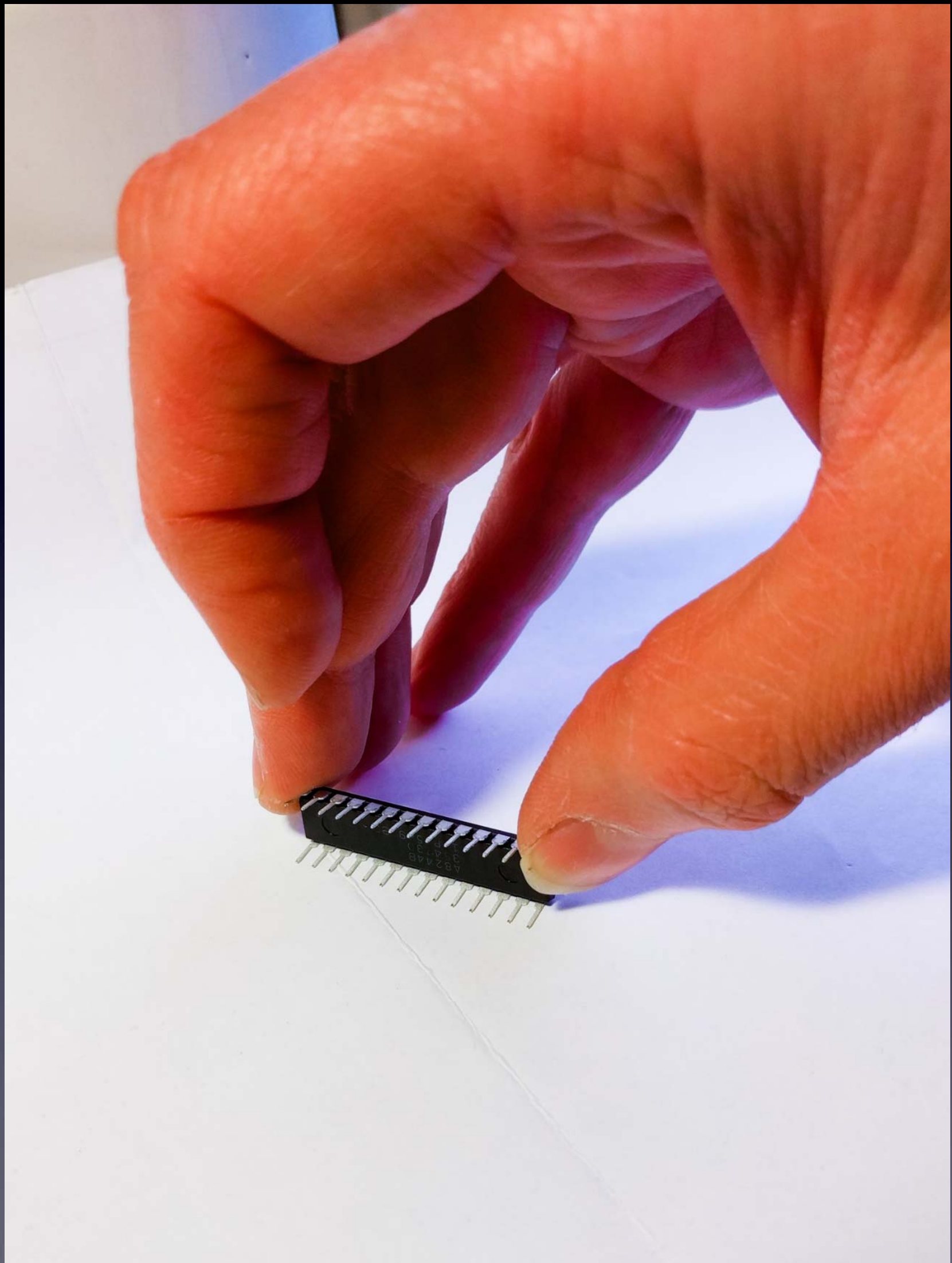

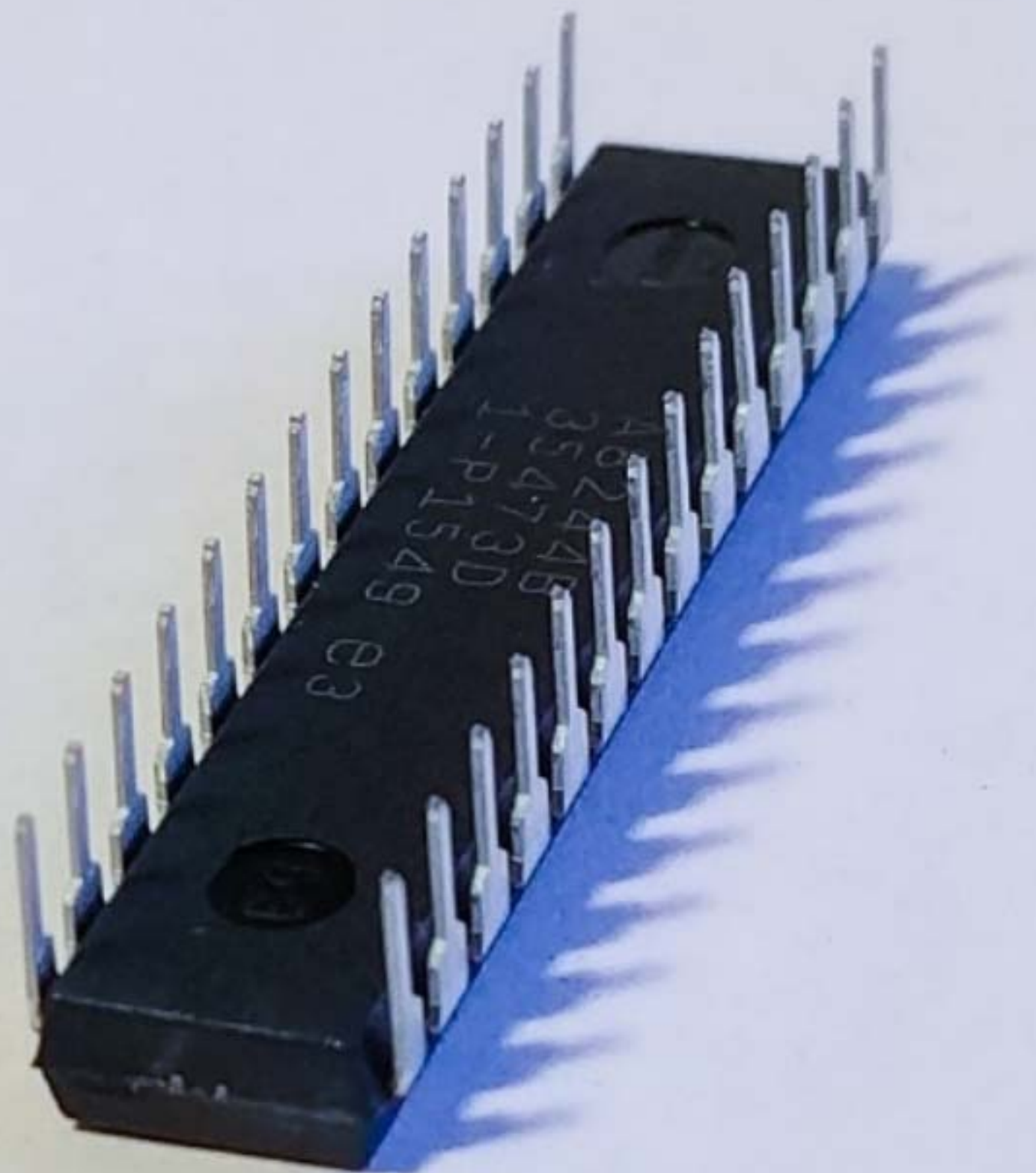

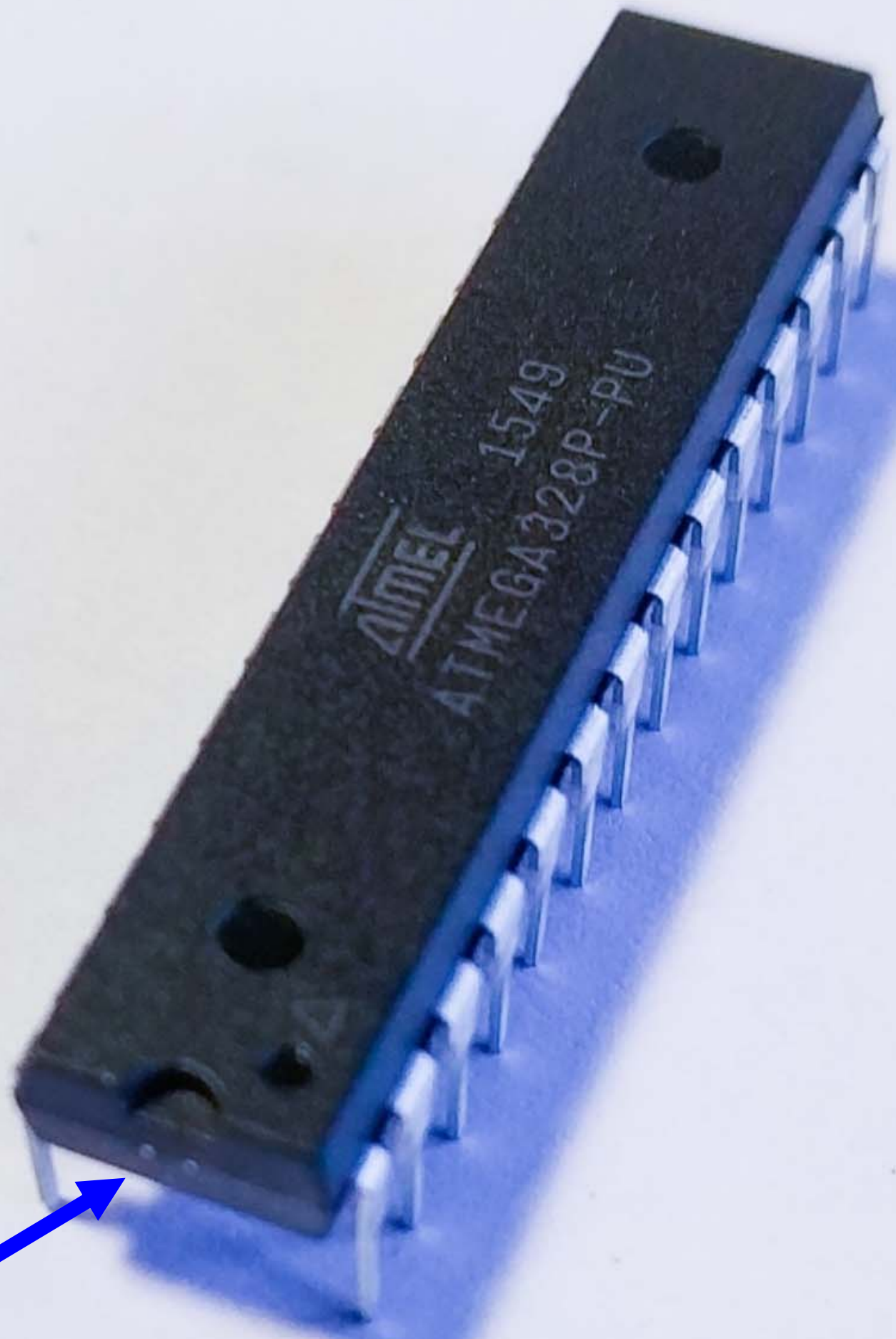

ATMEL 1549
ATMEGA 328P-PU



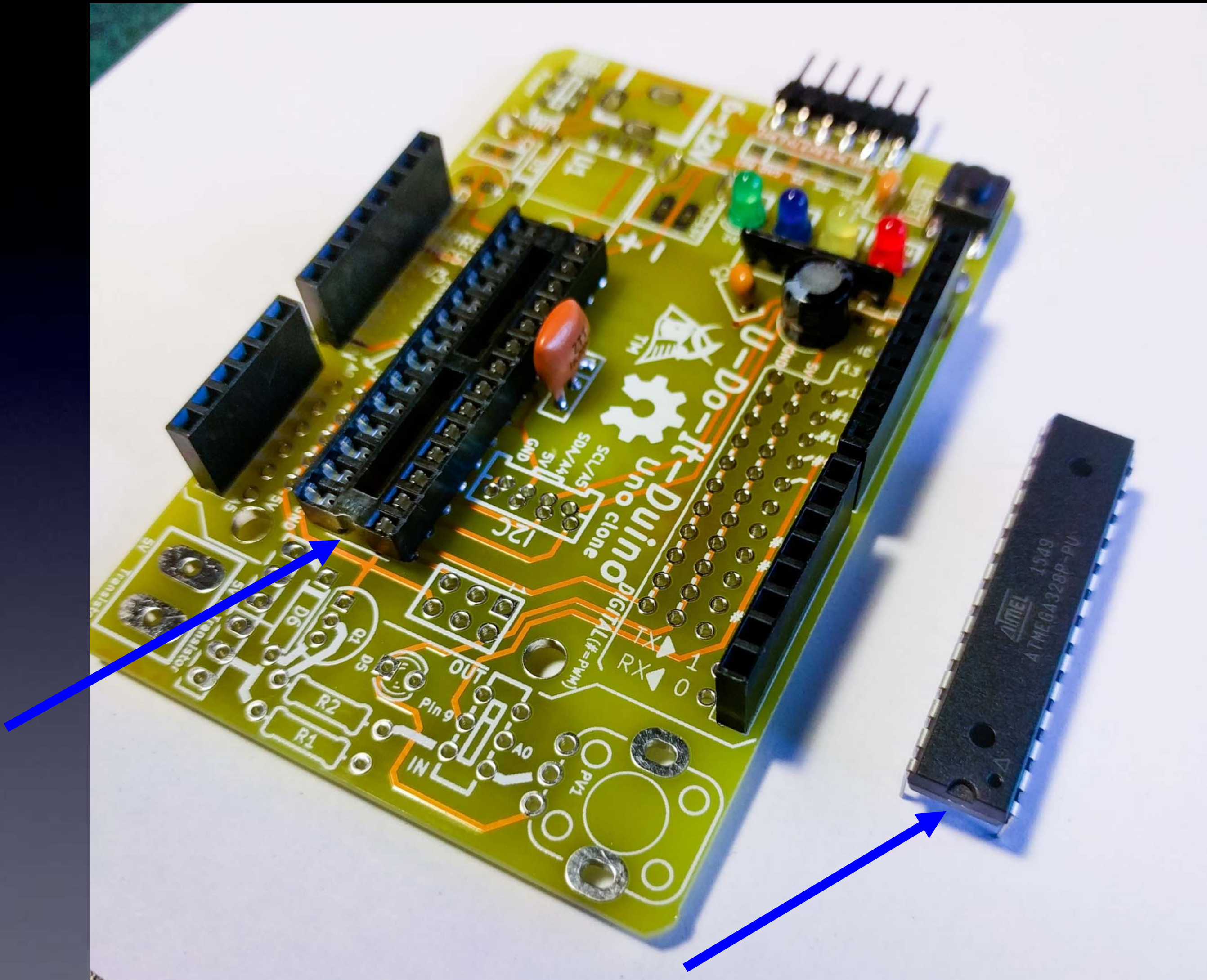

**Use both thumbs
to push chip
into socket**

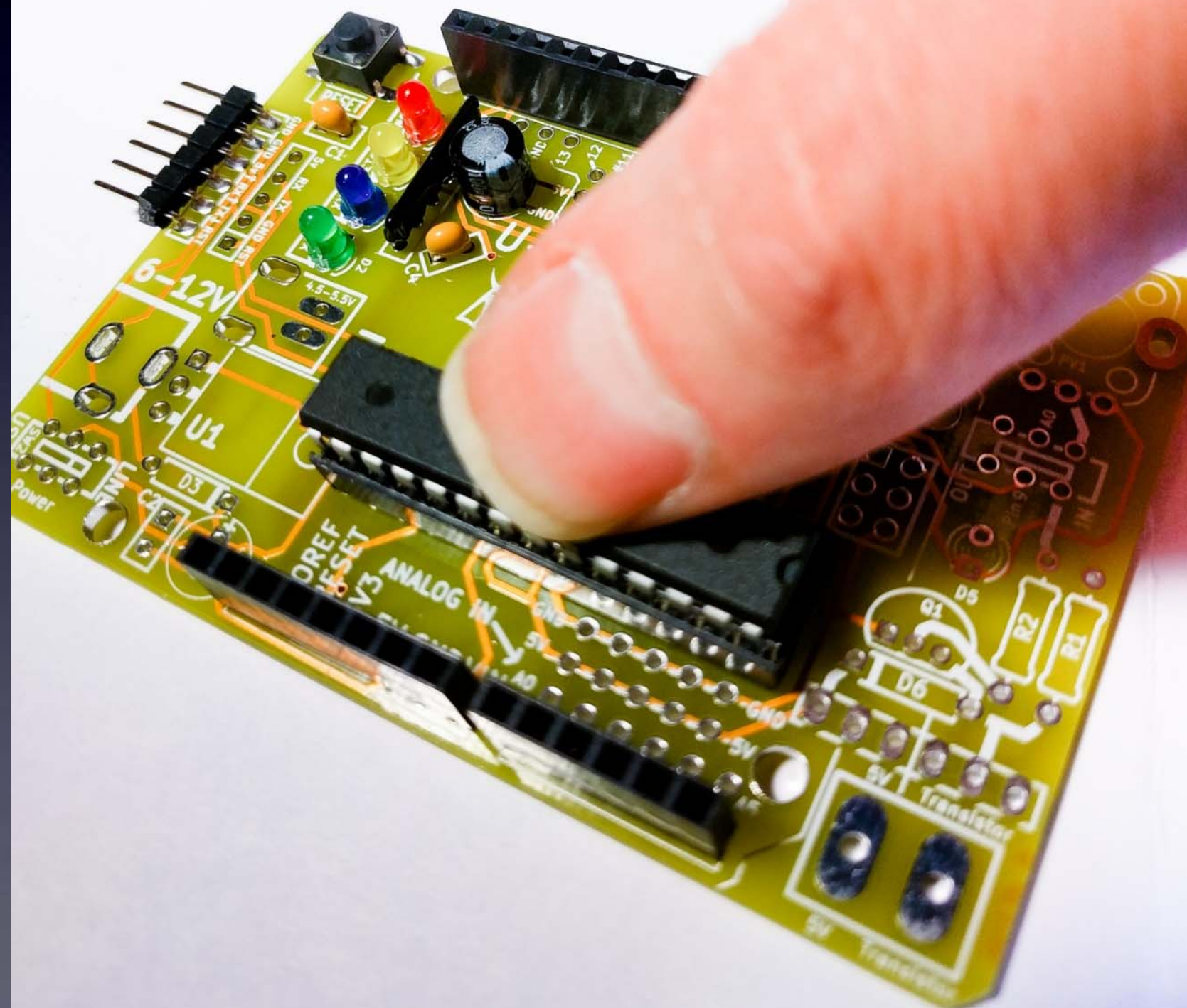

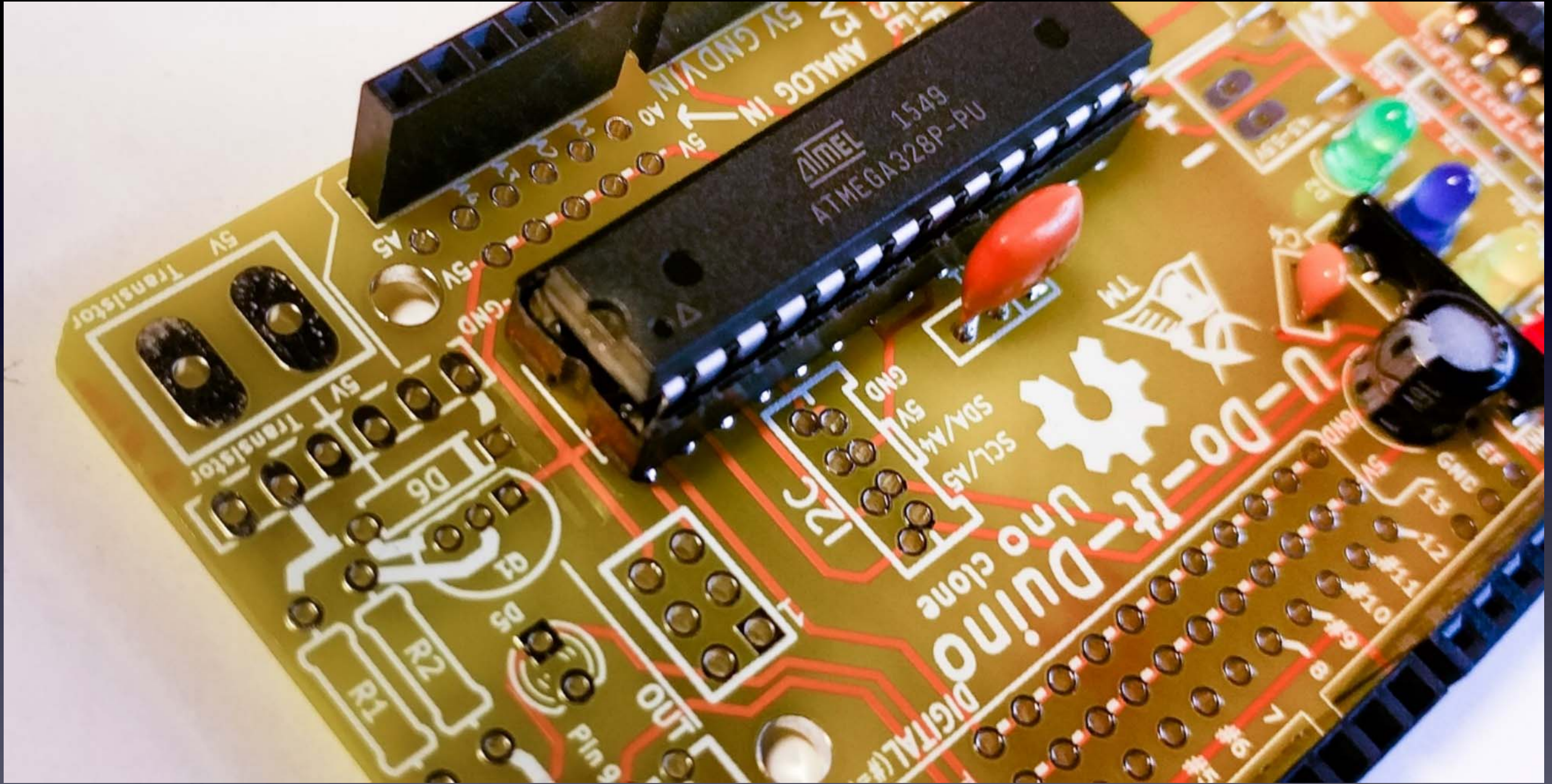

We're done!

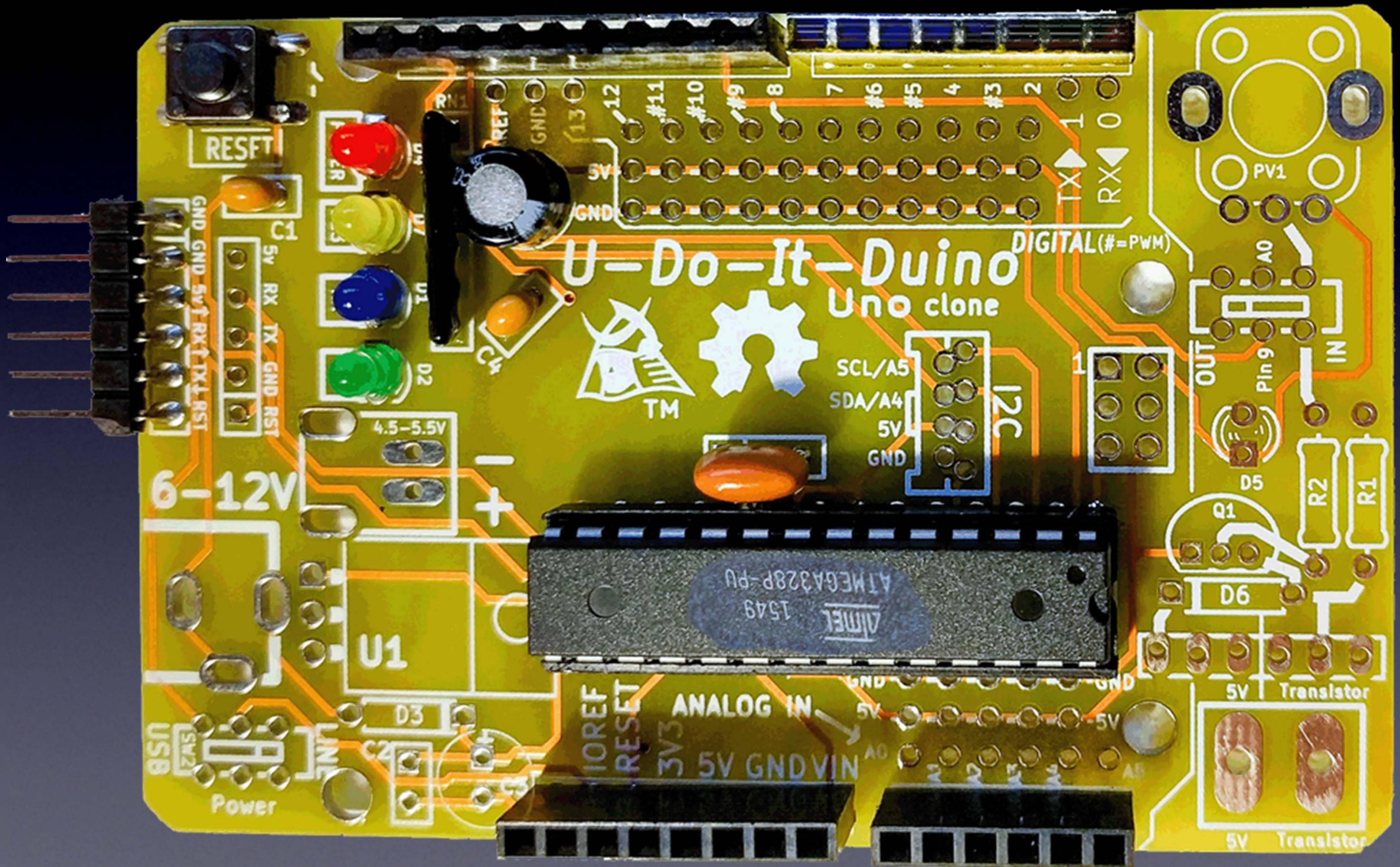

First test:

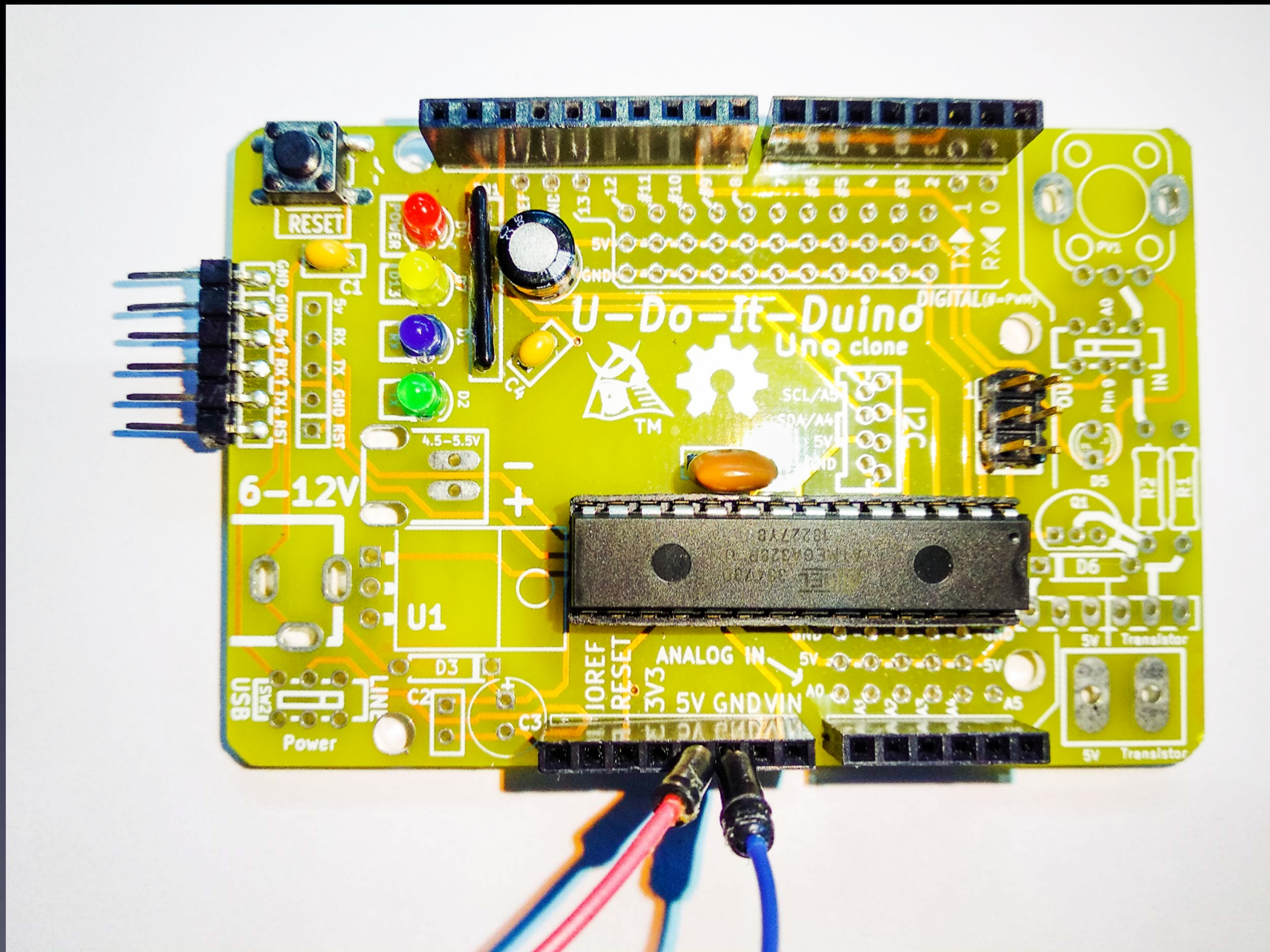

Connect power with a battery pack...

First test:

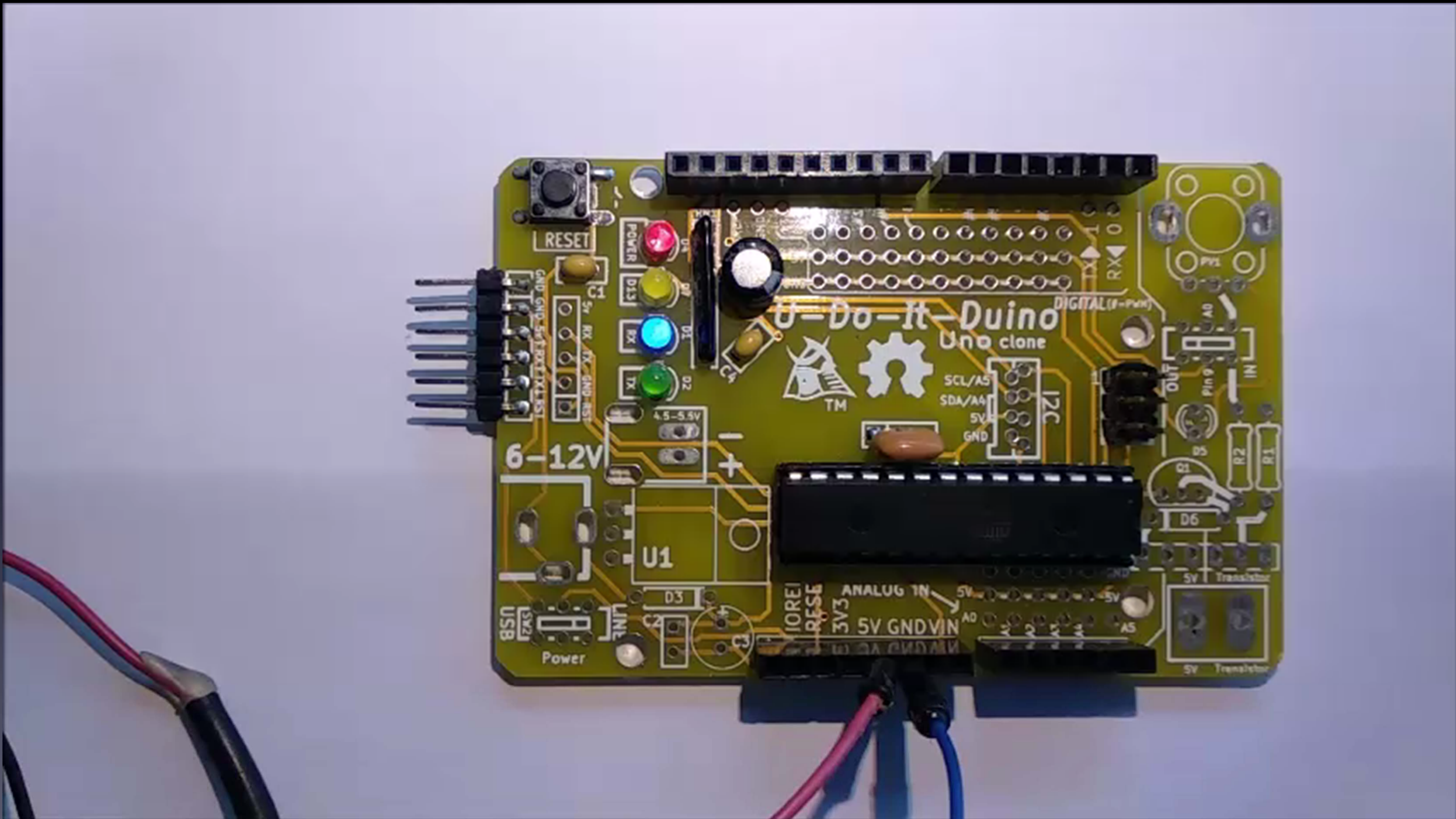

... and it blinks !

Now we can
connect parts to our Arduino,
and program it!

USB-Serial Cable

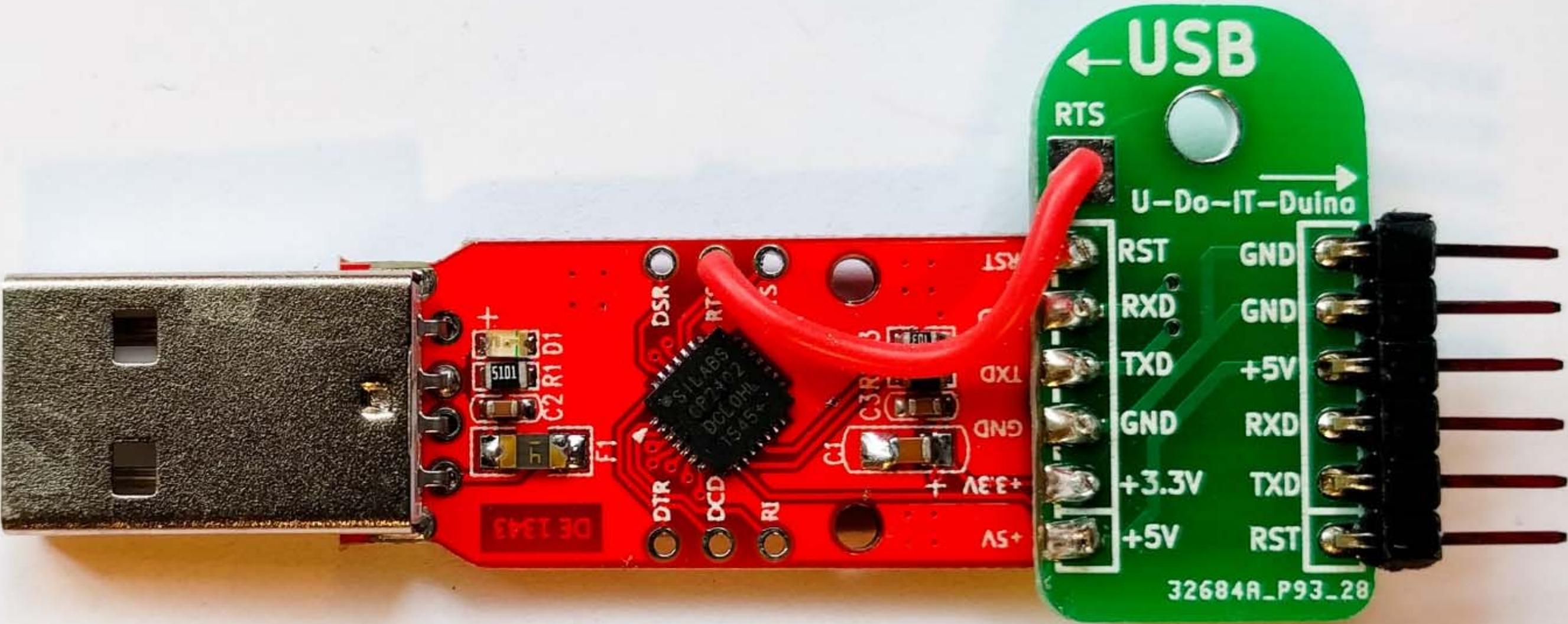

USB-Serial Cable Driver

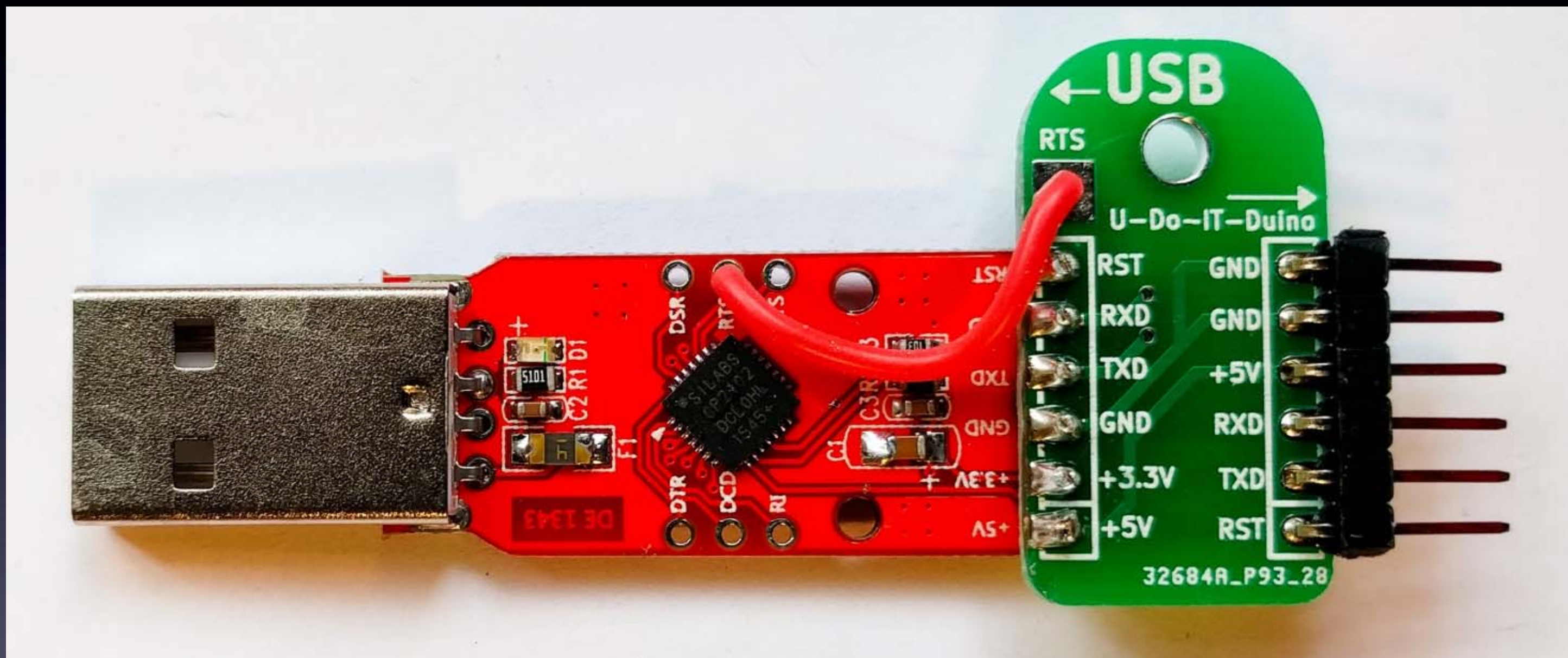

**You will need to download and install a driver
for your Operating System (Windows, MacOS, or Linux):**

<https://www.silabs.com/products/development-tools/software/usb-to-uart-bridge-vcp-drivers>

Helpful info

on the

Ardduino for(4) Total Newbies

workshop

web-page:

https://cornfieldelectronics.com/cfe/projects/tvbg_arduino/tvbg_arduino_workshop.php

TAKE CONTROL

At Cornfield Electronics we create devices that give people opportunities for effective choices in their lives. Each of us can decide whether to watch TV, and when to watch. Each of us can decide when to get the rest we want, and how we dream. Everyone can learn to make cool things with our kits. Please explore our [products](#), make your own choices, and see how *your* life can be enhanced.

[Join our mailing list](#)



Love it or hate it, TV is all around us. **TV-B-Gone®** universal remote control is the first fruit of our technical savvy, embodying our belief in empowerment, and sense of humor. This universal remote control fits in your pocket and allows you to discreetly turn TVs off or on wherever you go. TV-B-Gone fans around the world are using it for a variety of practical, philosophical, and humorous purposes. Imagine the possibilities...

Years in the making **NeuroDreamer®** sleep mask is the latest of our tools for personal empowerment. We all need rest, but we don't always get it in our

busy lives. Now with the help of NeuroDreamer sleep mask you can use your own brainwaves to bring you the rest you need. And with the lucid dreaming model, you can take control of your dreams. You can enhance your life. The choice is yours.

Want to learn electronics? We make **fun, intriguing, educational, useful kits!** NEW: **ArduTouch music synthesizer kit!**

We make truly useful technological solutions that put you in charge.

Welcome to our better world!

DO-IT-YOURSELF PROJECTS

by [Mitch Altman](#), and friends.
Last modified: 28-February-2019

You Can Make Cool Things With Microcontrollers!

The projects on this page were all created for total beginners, with no experience, to complete successfully at my workshops, or at home, or anywhere!

All you need is a desire, a handful of parts, a soldering iron (with stand and sponge), a wire-cutter, a wire-stripper, solder, and an afternoon.



Open Hardware!

Everything on this page (and everything I do) is free and open source!

(That's *free* as in *freedom*.)

If you have any questions on anything, please feel free to email me:

mitch AT CornfieldElectronics DOT com



Soldering!

Soldering is fun! And it is easy! Really, it is!

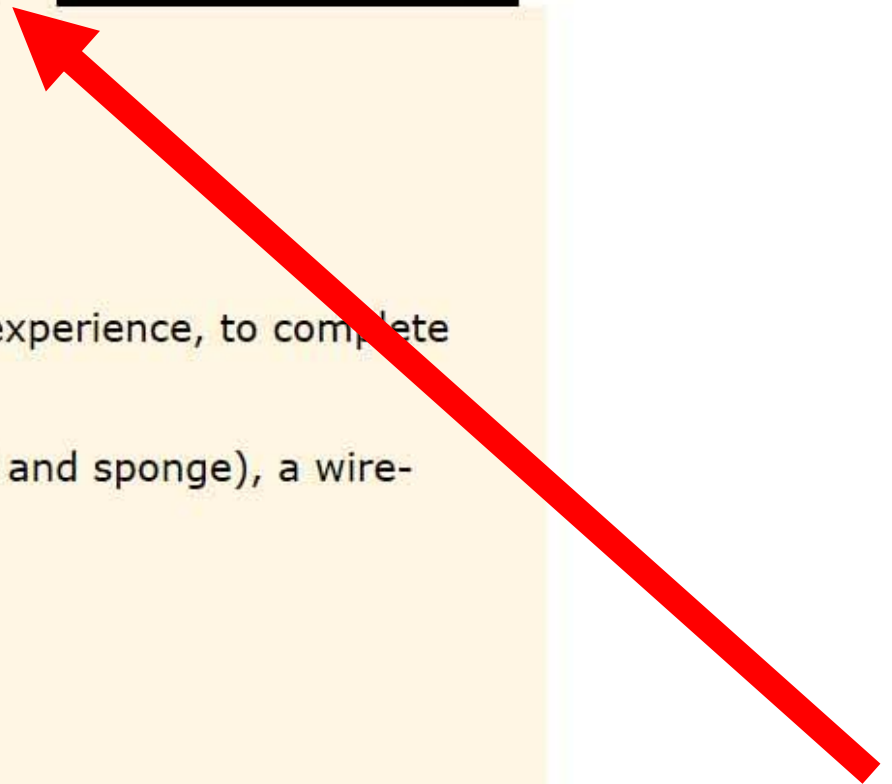



The TV-B-Gone Kit was originally developed from a MiniPOV3 hack (see below) (which, of course, I hacked from my original [TV-B-Gone](#).)

For excellent **assembly instructions**, please go to the [TV-B-Gone Kit page](#) of the of the Adafruit.com website.

For **questions** about the TV-B-Gone Kit, please go to the [TV-B-Gone Kit user forum](#). To see the **schematic, firmware, and board layout**, please go to [TV-B-Gone Kit downloads](#).

TV-B-Gone Kits are available for **purchase** from the [TVBGone.com](#) website.

Project: Arduino For Total Newbies workshop
-- Learn Arduino, and make your own TV-B-Gone!



This workshop covers lots of ground -- all you need to learn how to play with Arduinos. As an example project, you can make your own TV-B-Gone using [Arduino](#). Many thanks to Ken Shirriff for the original [TV-B-Gone for Arduino project](#)! For documentation on this workshop, please see the: [Arduino For Total Newbies Workshop](#) page.

scroll down





The TV-B-Gone Kit was originally developed from a MiniPOV3 hack (see below) (which, of course, I hacked from my original [TV-B-Gone](#).)

For excellent **assembly instructions**, please go to the [TV-B-Gone Kit page](#) of the of the Adafruit.com website.

For **questions** about the TV-B-Gone Kit, please go to the [TV-B-Gone Kit user forum](#). To see the **schematic, firmware, and board layout**, please go to [TV-B-Gone Kit downloads](#).

TV-B-Gone Kits are available for **purchase** from the [TVBGone.com](#) website.

Project: Arduino For Total Newbies workshop
-- Learn Arduino, and make your own TV-B-Gone!



This workshop covers lots of ground -- all you need to learn how to play with Arduinos. As an example project, you can make your own TV-B-Gone using [Arduino](#). Many thanks to Ken Shirriff for the original [TV-B-Gone for Arduino Project!](#) For documentation on this workshop, please see the: [Arduino For Total Newbies Workshop](#) page.

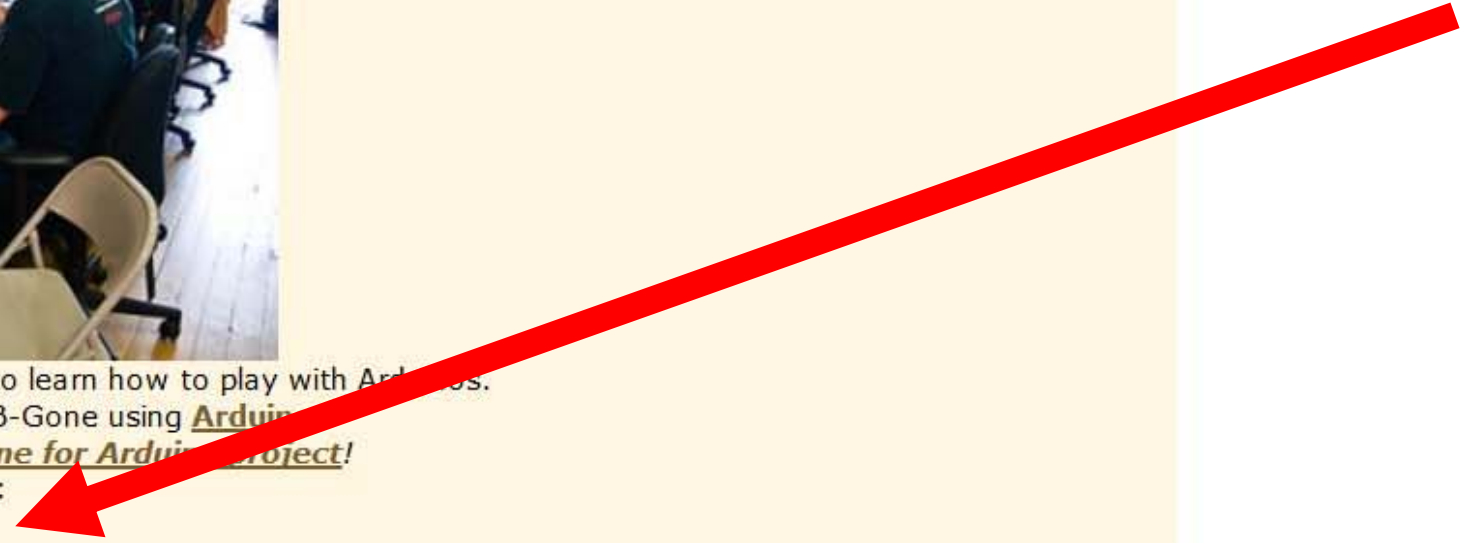



Arduino For Total Newbies Workshop

last updated: 5-March-2019

Learn how to make your own way cool projects with Arduino, using TV-B-Gone as an example project to learn from.



I've given this workshop at [Noisebridge](#) hackerspace in San Francisco (several times), at [27C3](#) and [28C3](#) in Berlin, and [29C3](#), [30C3](#), [31C3](#), [32C3](#), and [33C3](#) in Hamburg, and at [34C3](#) and [35C3](#) in Leipzig, at [CCCamp2011](#) and [CCCamp2015](#) outside of Berlin, at [HeatSync Labs](#) hackerspace in Phoenix, AZ, at [Fabelier](#) hackerspace in Paris, at Unit One in [2012](#), [2014](#), [2016](#), and [2018](#) as Hacker In Residence at the University of Illinois, in Urbana, IL, at Makerspace Urbana in Urbana, IL in [2012](#) and in [2016](#), at [Workshop Weekend](#) in Oakland, CA (twice), at [XinCheJian](#) hackerspace in Shanghai, at [Maker Carnival](#) in Beijing (twice) at several conferences and hackerspaces on my [Hackers on a Train Workshop Tour 2012](#) including at [HOPE Number 9](#) in New York City, at [ToorCamp 2012](#) in Neah Bay, WA, at [OHM 2013](#) and [SHA 2017](#) outside of Amsterdam, at [RockIT CoLabs](#) in San Francisco, at [Balcon2k14](#) in Novi Sad, Serbia, at [HOPE X](#), [The Eleventh HOPE](#), and [The Circle of HOPE](#) in New York City, at [at the iCenter](#) as Hacker In Residence at Tsingua Univeristy in Beijing, at [EMF Camp 2016](#) and [EMF Camp 2018](#) outside of London, at [Tami](#) hackerspace in Tel Aviv, at [Le Wagon](#) in Chendu.

Here is what is available for downloading for the Arduino For Total Newbies Workshop:

1) You need to download the latest **Arduino software for your computer** (Windows, Mac OS, or Linux):

[Arduino download page](#)

2) You need a **driver for your USB communications/programming cable**. Several different ones are available. Choose the driver for the cable you have and the operating system for your computer.

Samurai Circuits board (SiLabs CP210x USB-to-Serial TTL) drivers:

[The latest drivers from SiLabs' website](#)

The SiLabs driver is installed by default on most Linux systems.

Adafruit FTDI Friend drivers:

[The latest drivers from FTDI's website](#)

The FTDI driver is installed by default on most Linux systems.

FTDI Cable drivers:

[The latest drivers from FTDI's website](#)

The FTDI driver is installed by default on most Linux systems.

3) You also need the **TV-B-Gone Arduino Sketch** (download this, unzip it, and copy it to your computer in the "examples" folder inside your "arduino" folder that you downloaded):

[TV-B-Gone Arduino sketch\(22KB\)](#)

4) Schematic Diagram for Arduino TV-B-Gone remote control:

[Schematic Diagram\(449KB\)](#)

Parts List for Arduino TV-B-Gone remote control:

[Parts List \(Open Office\)\(12KB\)](#)

[Parts List \(MS Office\)\(9KB\)](#)

scroll down



The latest drivers from FTDI's website

The FTDI driver is installed by default on most Linux systems.

FTDI Cable drivers:

The latest drivers from FTDI's website

The FTDI driver is installed by default on most Linux systems.

3) You also need the **TV-B-Gone Arduino Sketch**
(download this, unzip it, and copy it to your computer in the "examples" folder inside your "arduino" folder that you downloaded):

[TV-B-Gone Arduino sketch\(22KB\)](#)

4) Schematic Diagram for Arduino TV-B-Gone remote control:

[Schematic Diagram\(449KB\)](#)

Parts List for Arduino TV-B-Gone remote control:

[Parts List \(Open Office\)\(12KB\)](#)

[Parts List \(MS Office\)\(9KB\)](#)

Schematics for the Arduino clone kits:

[U-Do-It-Duino schematic \(110KB\)](#)

[BoArduino schematic \(40KB\)](#)

[Diavolino schematic \(38KB\)](#)

Soldering Is Easy comic book:

[Solder Comic \(English\) \(809KB\)](#)

Many other languages are available!

Here are links to the slides I use in the workshop:

[Arduino For Total Newbies workshop slides \(with U-Do-It-Duino kit\) \(65.5MB\)](#)

[Arduino For Total Newbies workshop slides \(with Arduino Uno -- no soldering\) \(55.5MB\)](#)

scroll down

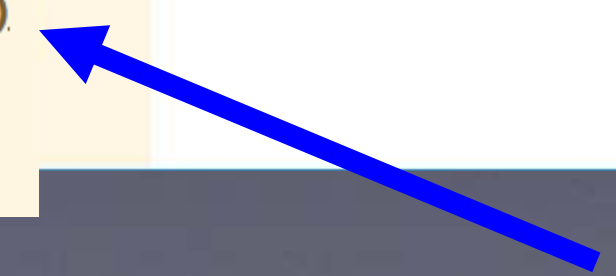
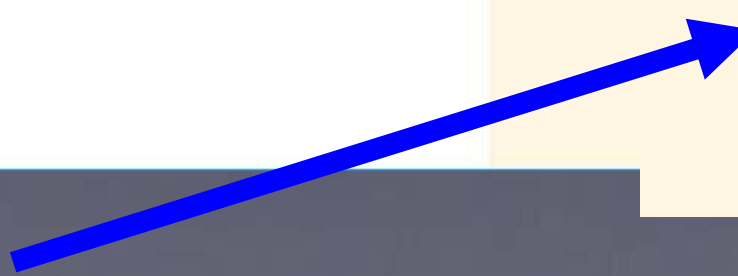

1) You need to download the latest **Arduino software for your computer** (Windows, Mac OS, or Linux):

[Arduino download page](#)

The screenshot shows a web browser window with the URL <https://www.arduino.cc/en/Main/Software>. The page features the Arduino logo and a navigation menu with options: HOME, STORE, SOFTWARE (highlighted), EDUCATION, RESOURCES, COMMUNITY, and HELP. A language dropdown menu is set to ENGLISH. The main content area is titled 'SOFTWARE' and features a decorative grid background with various colored dots. A central section promotes the 'ARDUINO WEB EDITOR' with a sub-header 'ARDUINO WEB EDITOR' and a description: 'Start coding online with the Arduino Web Editor, save your sketches in the cloud, and always have the most up-to-date version of the IDE, including all the contributed libraries and support for new Arduino boards.' To the left of this text is a small image of the web editor interface showing a code editor with the following code:

```
void setup(){  
  }  
  
void loop(){  
  }  
}
```

 To the right of the text are two buttons: 'GETTING STARTED' and 'CODE ONLINE'. Below the main content area, the text 'Download the Arduino IDE' is displayed. At the bottom right, there are two download options: 'Windows Installer, for Windows XP and up' and 'Windows ZIP file for non admin install'.

2) You need a **driver for your USB communications/programming cable**. Several different ones are available. Choose the driver for the cable you have and the operating system for your computer.

Samurai Circuits board (SiLabs CP210x USB-to-Serial TTL) drivers:

[The latest drivers from SiLabs' website](#)

The SiLabs driver is installed by default on most Linux systems.

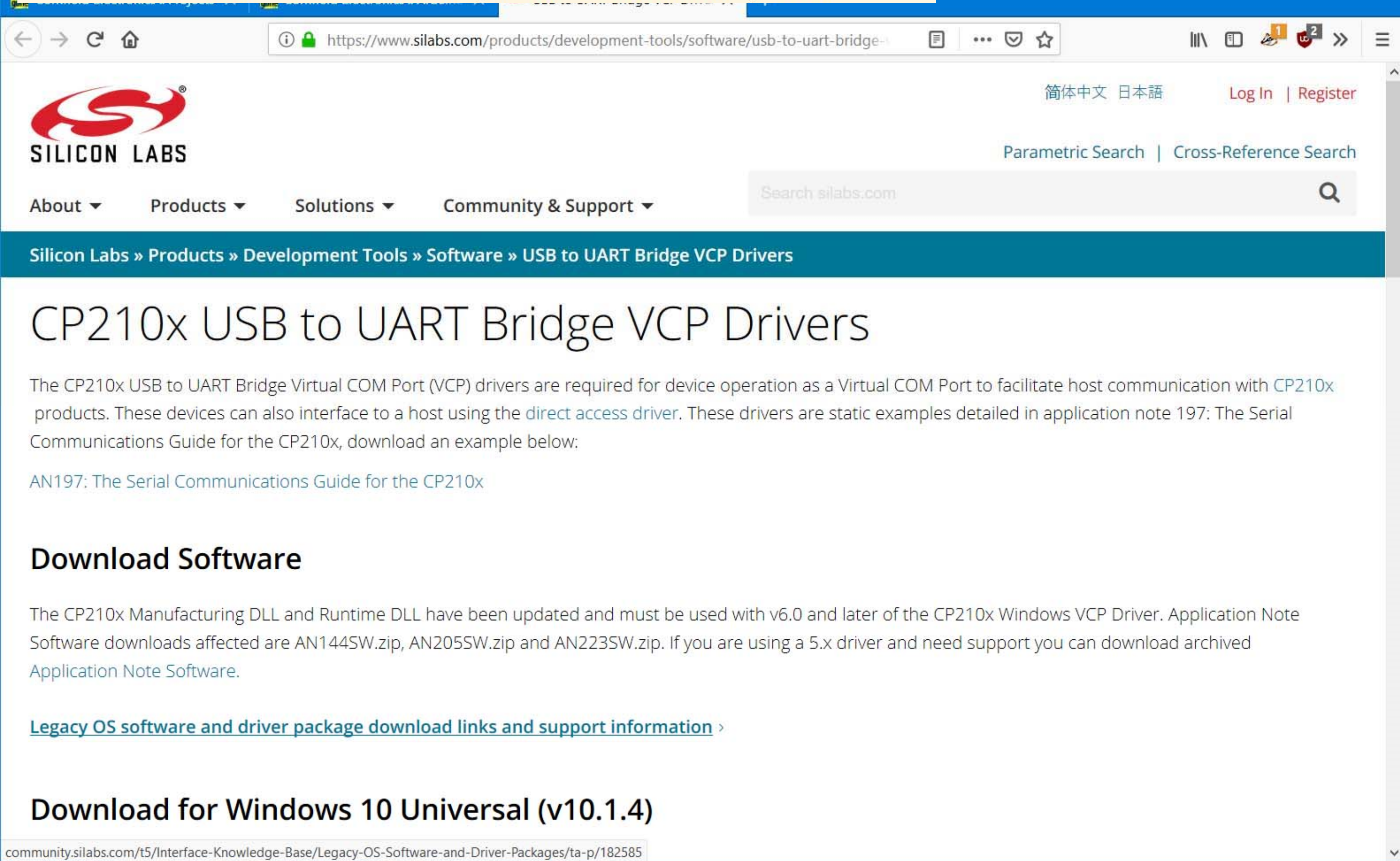

The screenshot shows a web browser window displaying the Silicon Labs website. The address bar shows the URL: <https://www.silabs.com/products/development-tools/software/usb-to-uart-bridge->. The page header includes the Silicon Labs logo, navigation links for About, Products, Solutions, and Community & Support, and a search bar. The main content area features a breadcrumb trail: [Silicon Labs](#) » [Products](#) » [Development Tools](#) » [Software](#) » [USB to UART Bridge VCP Drivers](#). The title of the page is "CP210x USB to UART Bridge VCP Drivers". The text explains that these drivers are required for device operation as a Virtual COM Port to facilitate host communication with CP210x products. It also mentions that these devices can interface to a host using the [direct access driver](#). A link to "AN197: The Serial Communications Guide for the CP210x" is provided. The "Download Software" section states that the CP210x Manufacturing DLL and Runtime DLL have been updated and must be used with v6.0 and later of the CP210x Windows VCP Driver. It lists affected software downloads: AN144SW.zip, AN205SW.zip, and AN223SW.zip. A link to "Legacy OS software and driver package download links and support information" is also present. The page footer shows the URL: community.silabs.com/t5/Interface-Knowledge-Base/Legacy-OS-Software-and-Driver-Packages/ta-p/182585.

CP210x USB to UART Bridge VCP Drivers

The CP210x USB to UART Bridge Virtual COM Port (VCP) drivers are required for device operation as a Virtual COM Port to facilitate host communication with CP210x products. These devices can also interface to a host using the [direct access driver](#). These drivers are static examples detailed in application note 197: The Serial Communications Guide for the CP210x, download an example below:

[AN197: The Serial Communications Guide for the CP210x](#)

Download Software

The CP210x Manufacturing DLL and Runtime DLL have been updated and must be used with v6.0 and later of the CP210x Windows VCP Driver. Application Note Software downloads affected are AN144SW.zip, AN205SW.zip and AN223SW.zip. If you are using a 5.x driver and need support you can download archived [Application Note Software](#).

[Legacy OS software and driver package download links and support information](#) >

Download for Windows 10 Universal (v10.1.4)

3) You also need the **TV-B-Gone Arduino Sketch** (download this, unzip it, and copy it to your computer in the "examples" folder inside your "arduino" folder that you downloaded):

[TV-B-Gone Arduino sketch\(22KB\)](#)

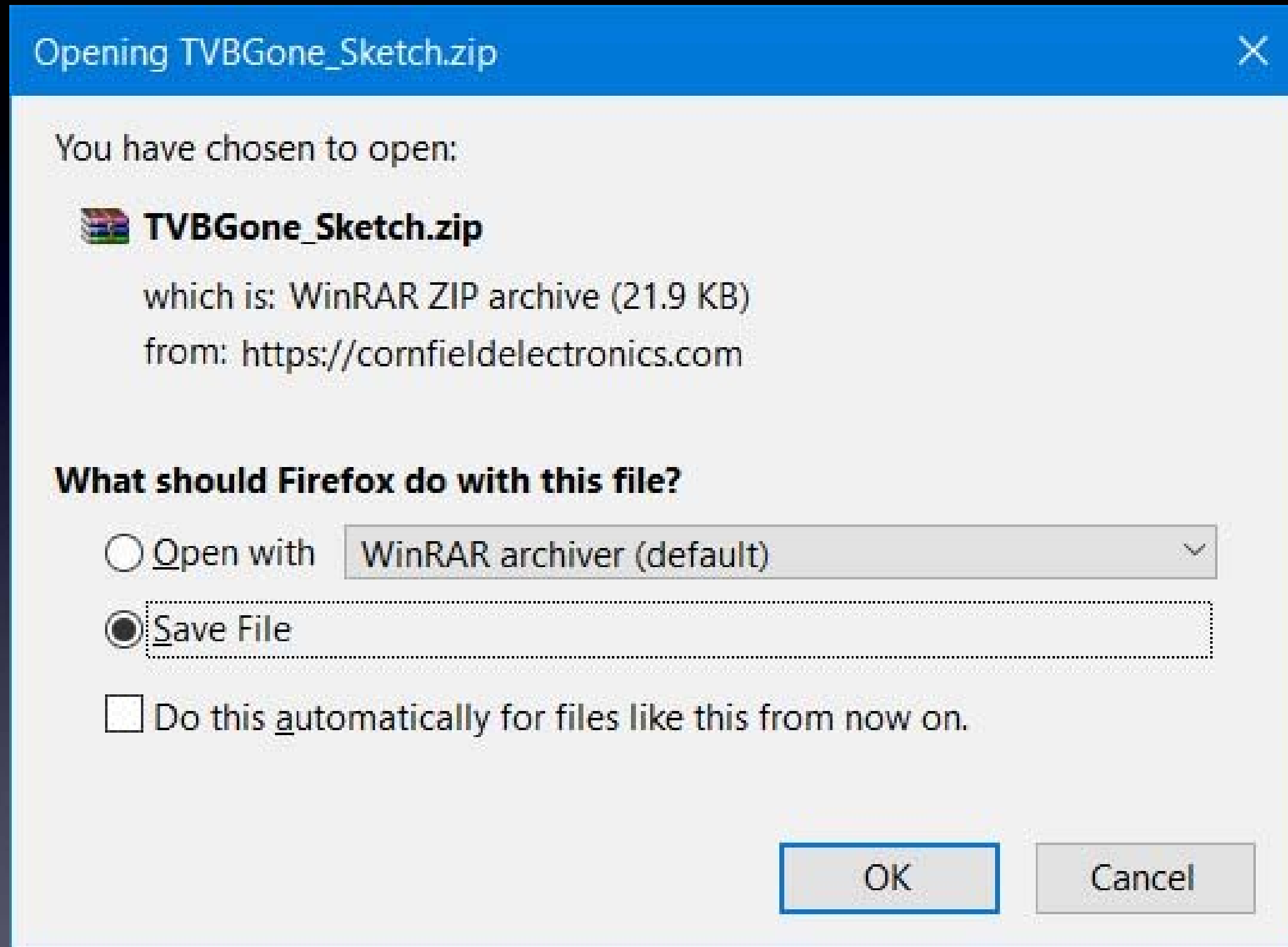

4) Schematic Diagram for Arduino TV-B-Gone remote control: Schematic Diagram(449KB)

File Edit View History Bookmarks Tools Help

Cornfield Electronics :: Projects X Cornfield Electronics :: Arduino X arduino_tvbgone_schematic.pdf X +

https://cornfielelectronics.com/cfe/projects/tvbg_arduino/arduino_tvbgone_schematic.pdf

1 of 1 70%

Arduino For Total Newbies

4-Sep-2015

Mitch Altman (original TV-B-Gone hardware and firmware, modified TV-B-Gone Arduino design)
Limore Fried (firmware modifications, kit design)
Ken Shirriff (original modifications for Arduino)
Johannes Schneemann (documentation)

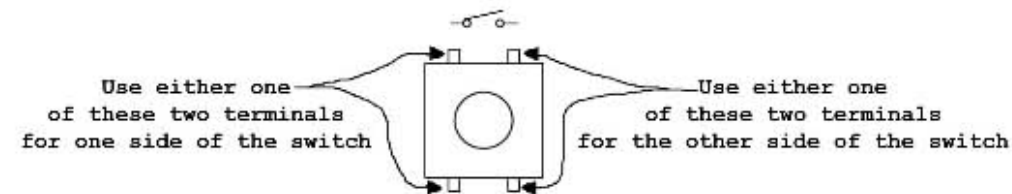
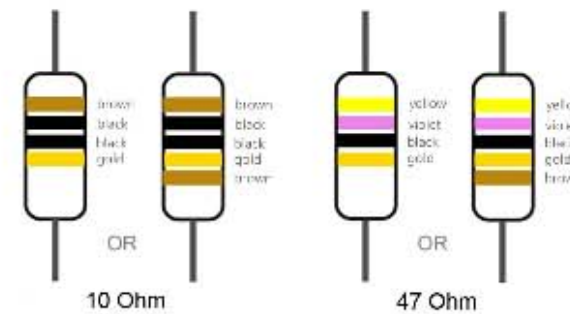
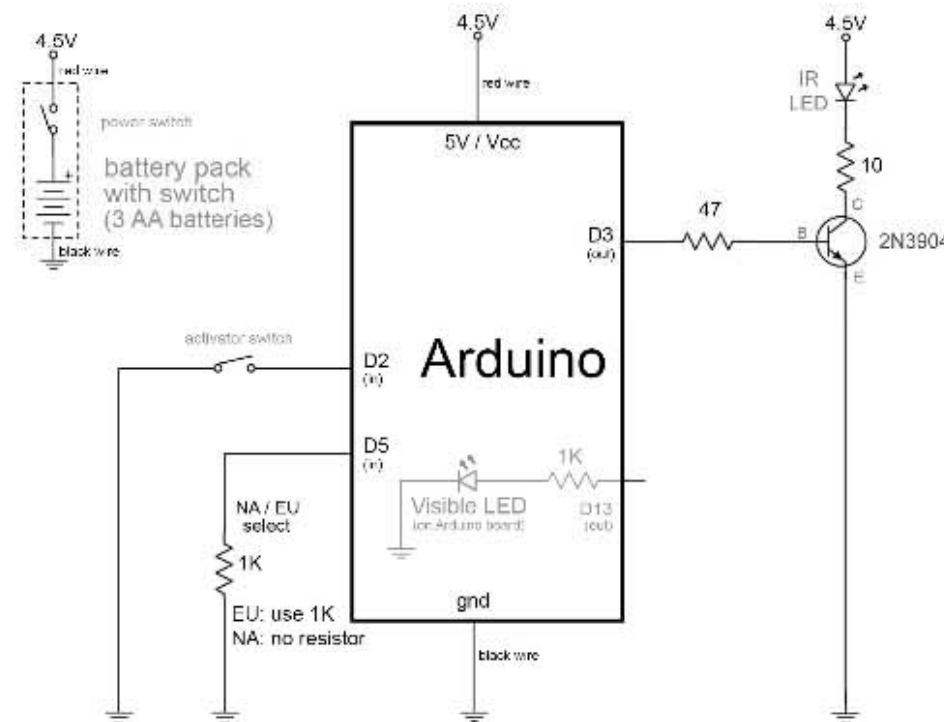

USB-Serial Cable

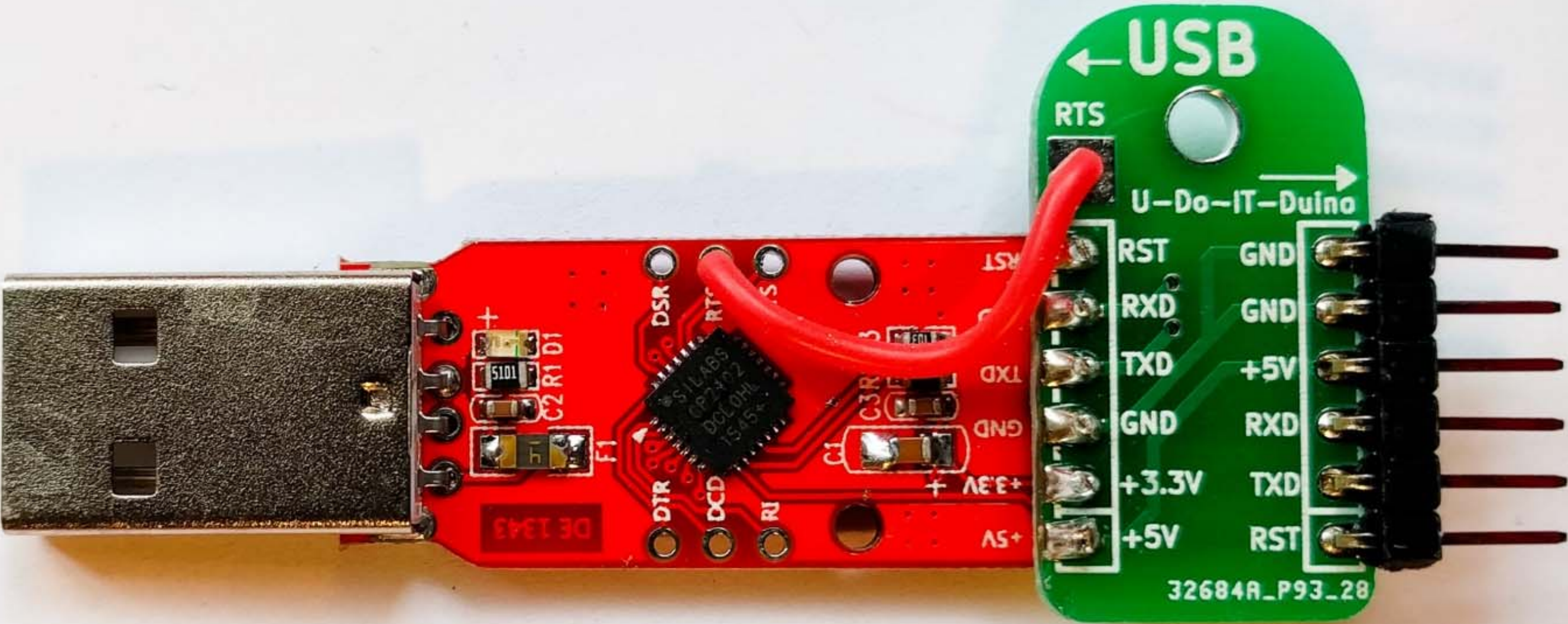

To computer's USB

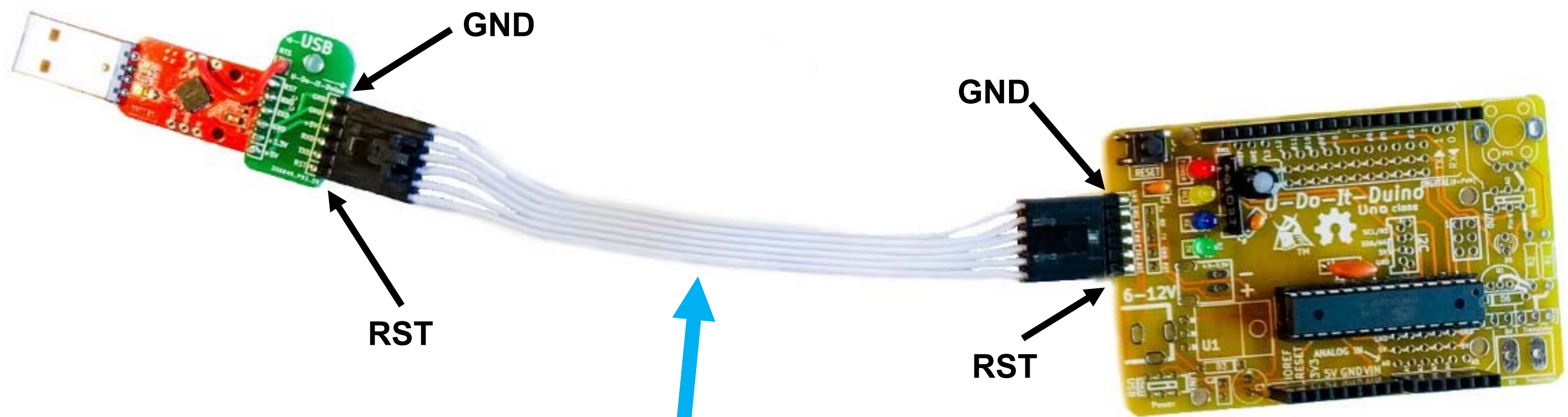

GND

RST

GND

RST

no twists

Arduino

After you download and install the Arduino software start it, and you will see a screen that looks like this:

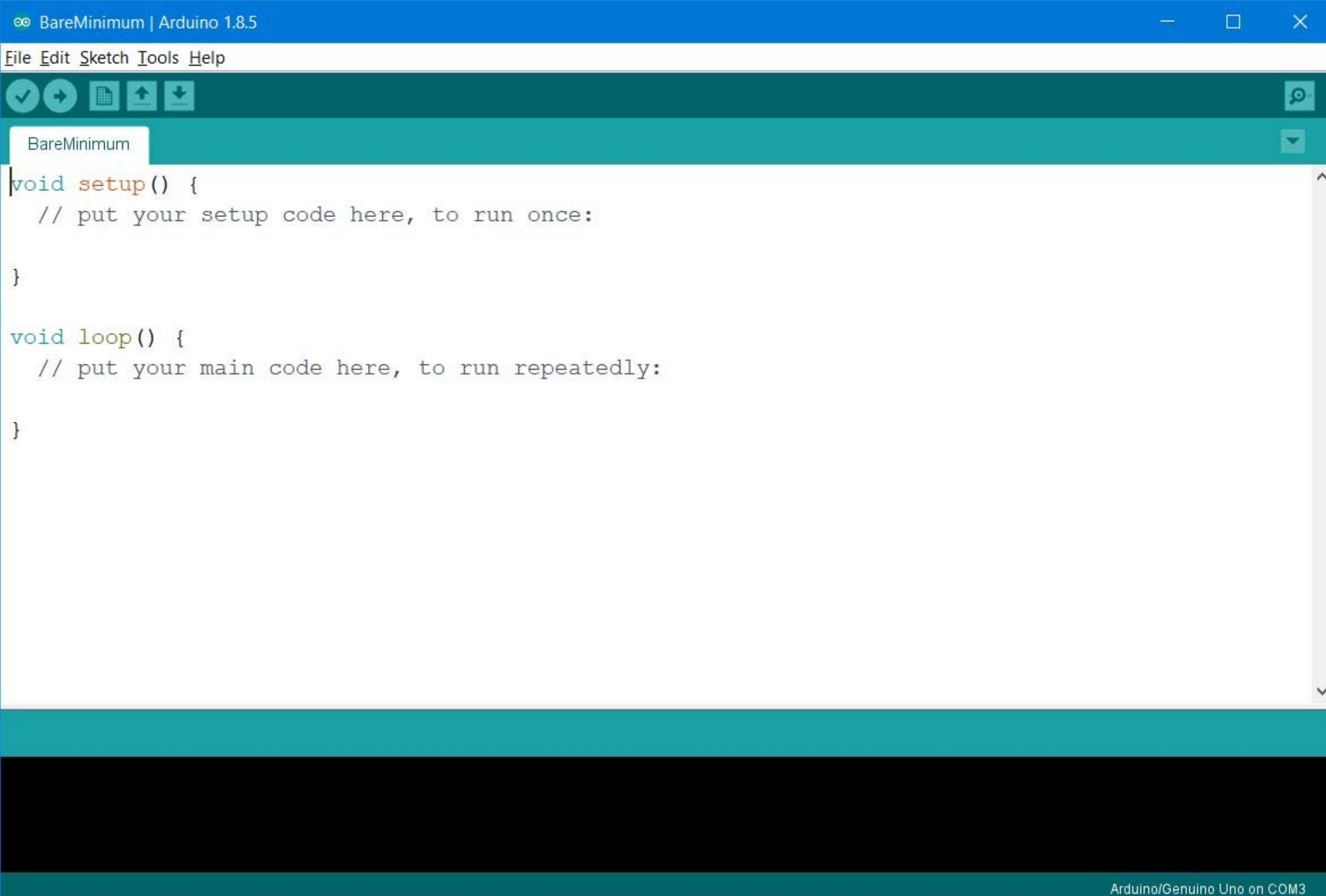

The screenshot shows the Arduino IDE interface. The title bar reads "BareMinimum | Arduino 1.8.5". The menu bar includes "File", "Edit", "Sketch", "Tools", and "Help". Below the menu bar is a toolbar with icons for saving, undo, redo, and uploading. The main workspace shows a sketch named "BareMinimum" with the following code:

```
void setup() {  
  // put your setup code here, to run once:  
  
}  
  
void loop() {  
  // put your main code here, to run repeatedly:  
  
}
```

At the bottom right of the IDE, the status bar indicates "Arduino/Genuino Uno on COM3".

Arduino

How to Set Up and Use the Arduino Software

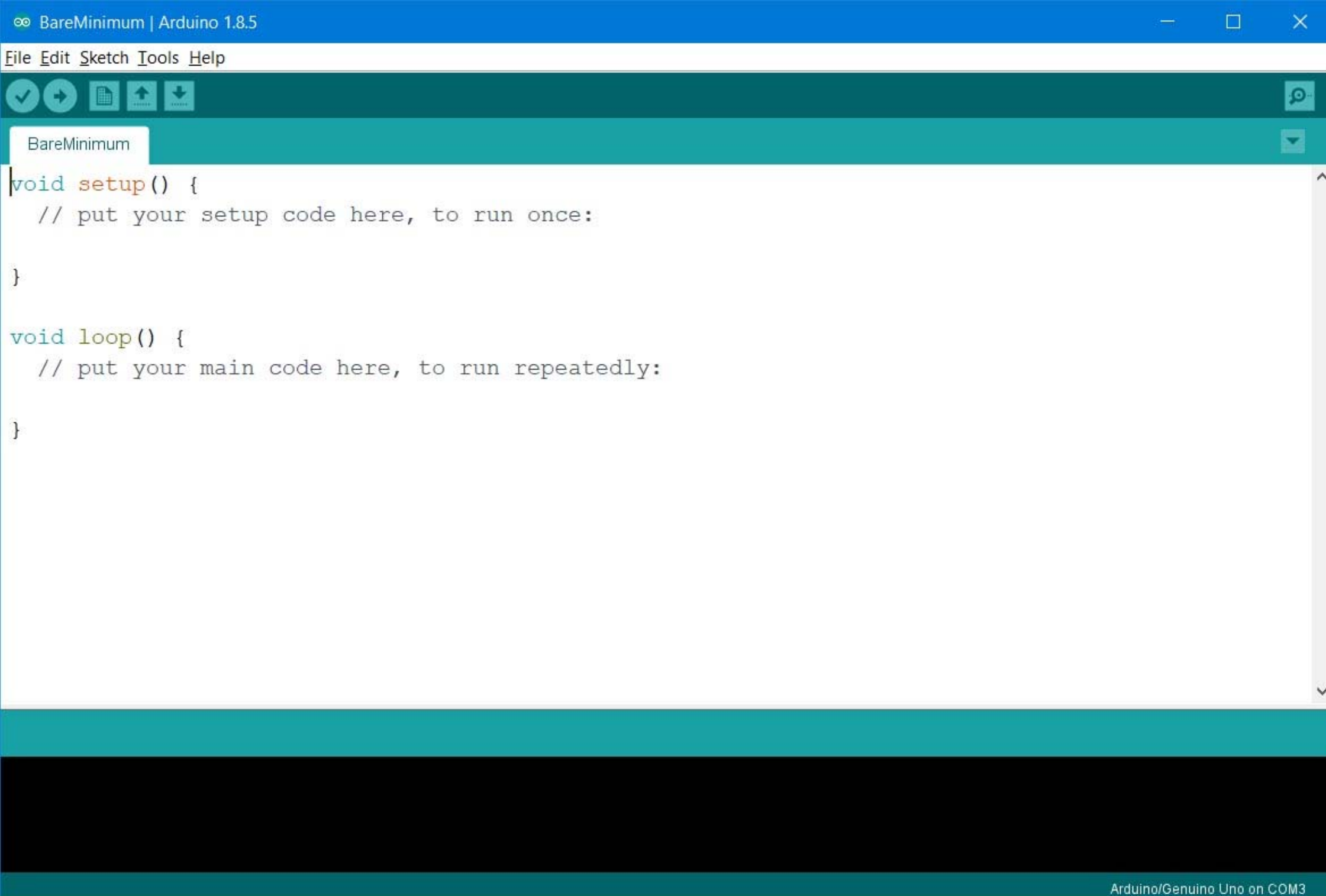

The screenshot displays the Arduino IDE interface. The title bar reads "BareMinimum | Arduino 1.8.5". The menu bar includes "File", "Edit", "Sketch", "Tools", and "Help". Below the menu bar is a toolbar with icons for saving, undo, redo, and uploading. The main workspace shows a sketch named "BareMinimum" with the following code:

```
void setup() {  
  // put your setup code here, to run once:  
  
}  
  
void loop() {  
  // put your main code here, to run repeatedly:  
  
}
```

At the bottom right of the IDE, the status bar indicates "Arduino/Genuino Uno on COM3".

Arduino

The **first time** you start your Arduino software you need to do **two things** to set things up:

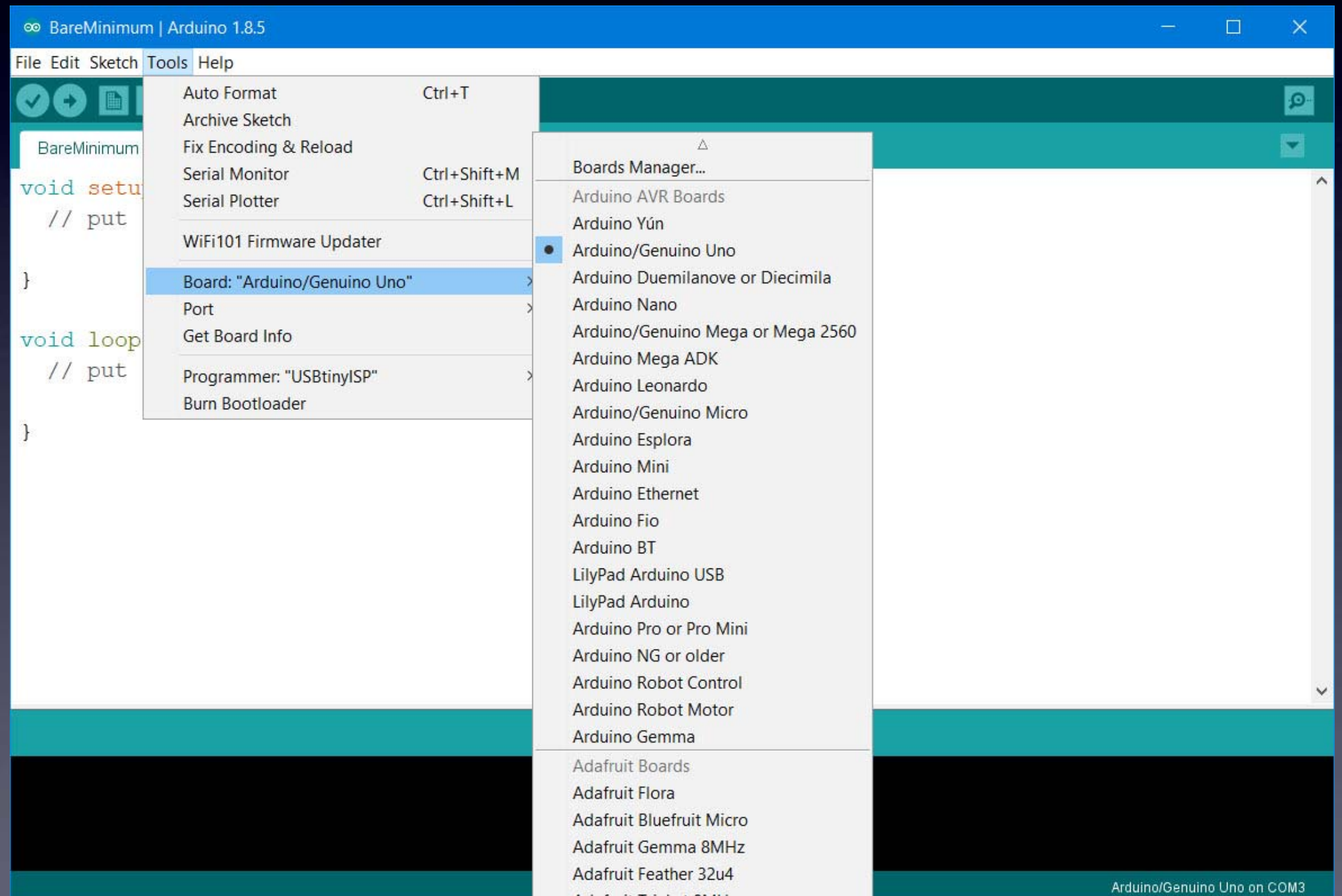

(1)
Choose "Uno"
as the Board

(Your
U-Do-It-Duino
acts
just like
an
Arduino Uno board)

Arduino

The **first time** you start your Arduino software you need to do **two things** to set things up:

(2)
Choose
the Port
(this will be
different
depending on
your Operating
System)

(After installing
the driver for
your USB-Serial cable
and plugging it in
your operating system
will see a serial port
and it appears here.)

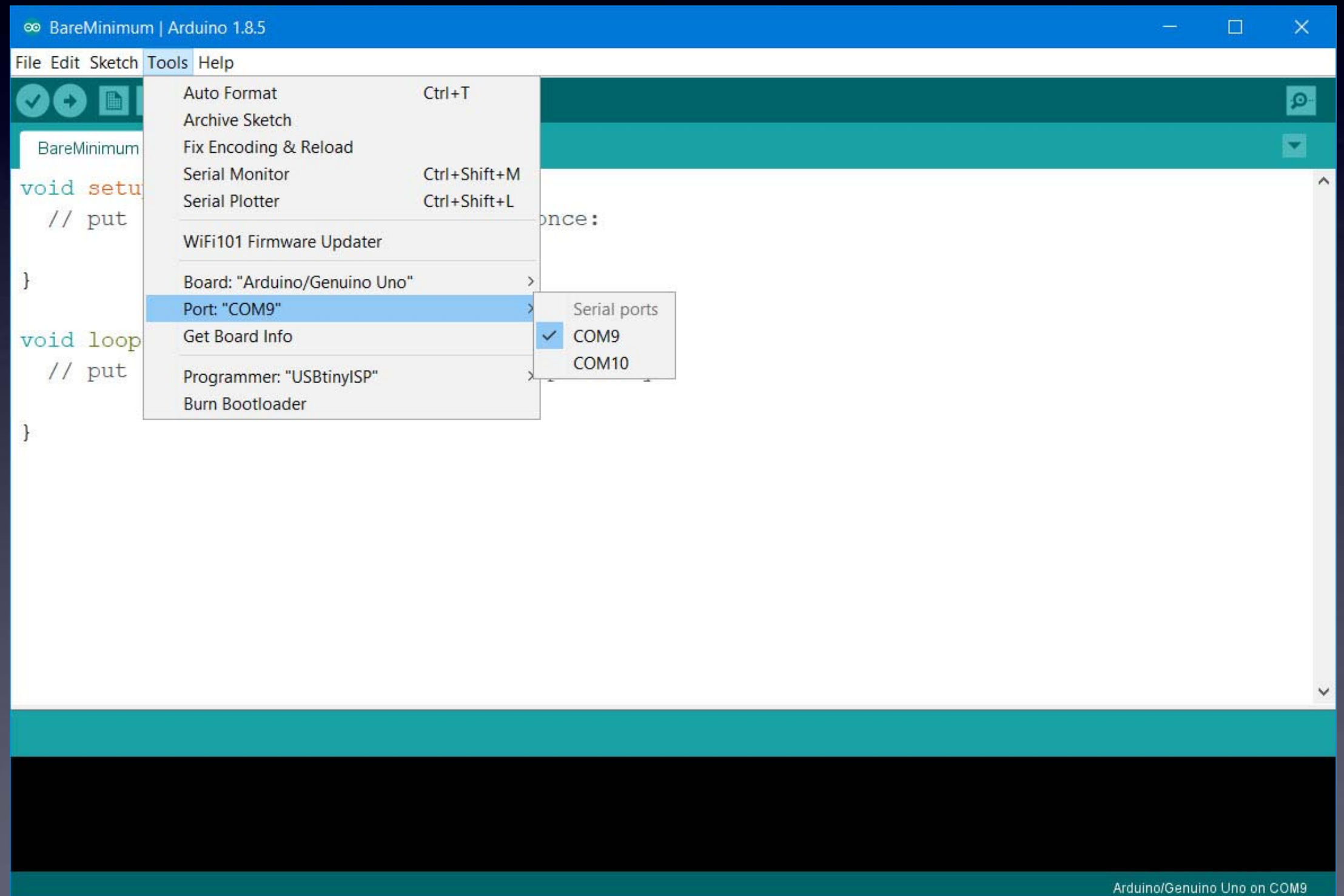

Arduino

Your Arduino software is now ready to program your U-Do-It-Duino !

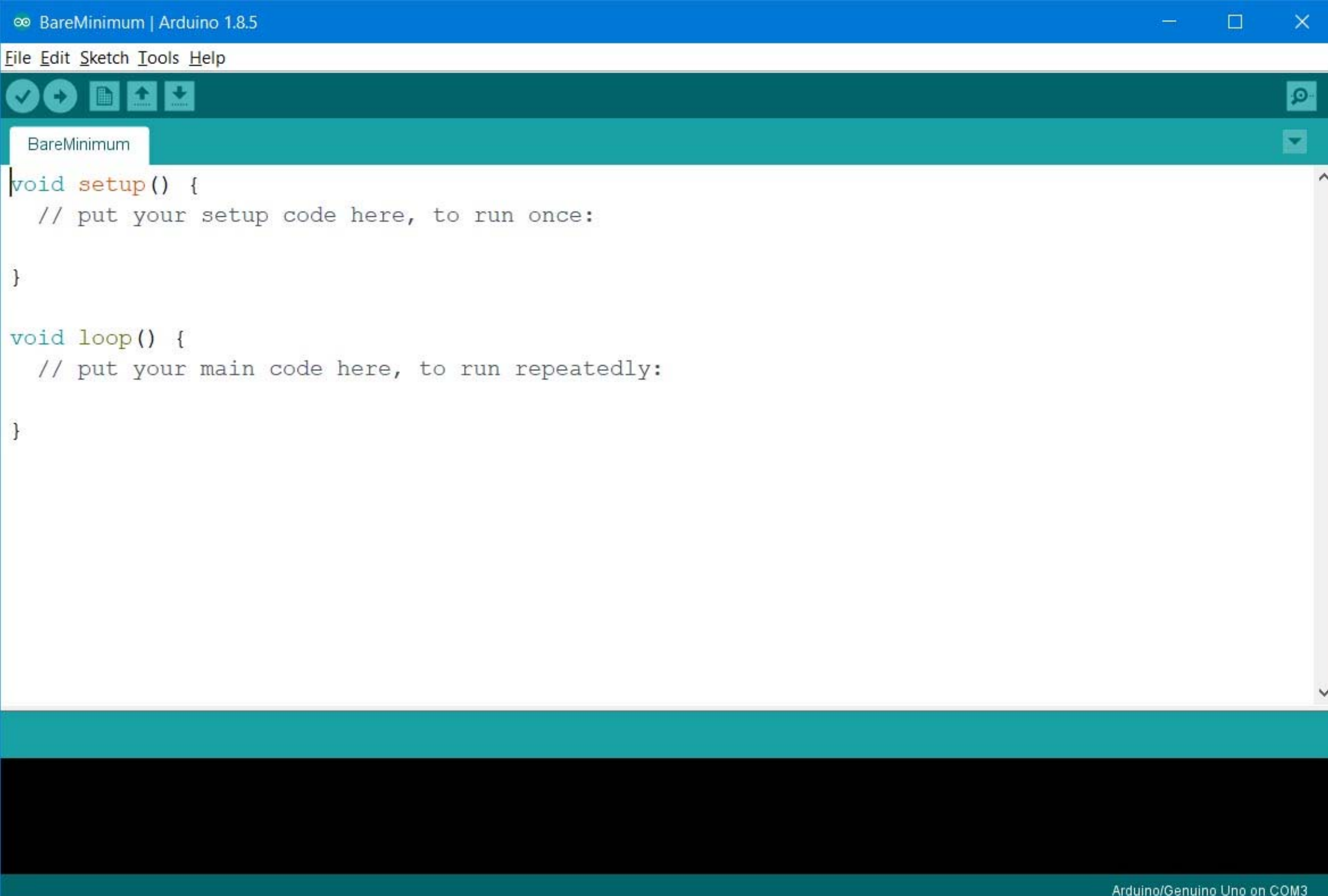

```
BareMinimum | Arduino 1.8.5
File Edit Sketch Tools Help
BareMinimum
void setup() {
  // put your setup code here, to run once:
}

void loop() {
  // put your main code here, to run repeatedly:
}

Arduino/Genuino Uno on COM3
```

Arduino

Your Arduino software is now ready to program your U-Do-It-Duino !

Let's make an LED blink! Hello World

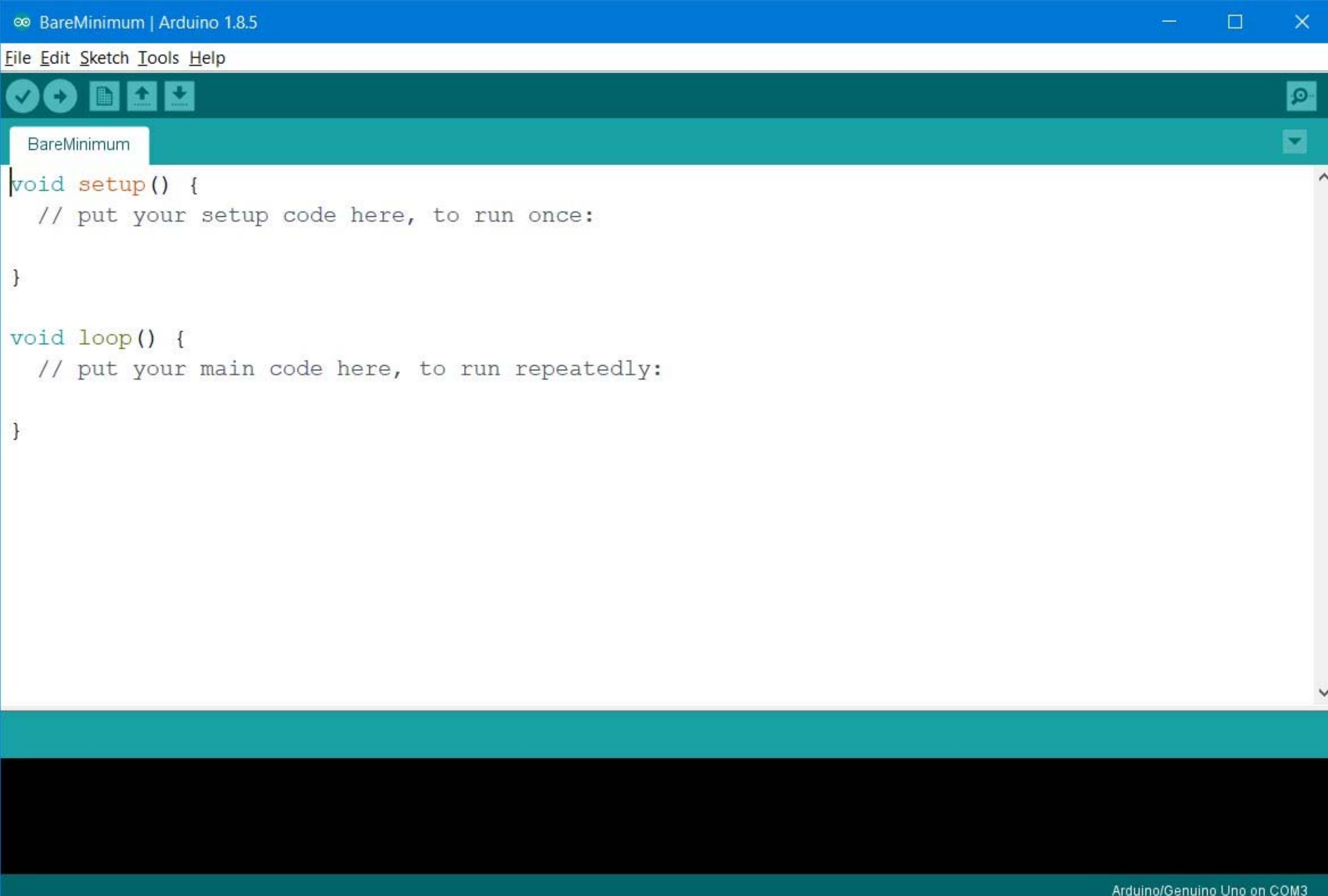

```
BareMinimum | Arduino 1.8.5
File Edit Sketch Tools Help
BareMinimum
void setup() {
  // put your setup code here, to run once:
}

void loop() {
  // put your main code here, to run repeatedly:
}

Arduino/Genuino Uno on COM3
```

Arduino

Your Arduino software is now ready to program your U-Do-It-Duino !

Let's make an LED blink! Hello World

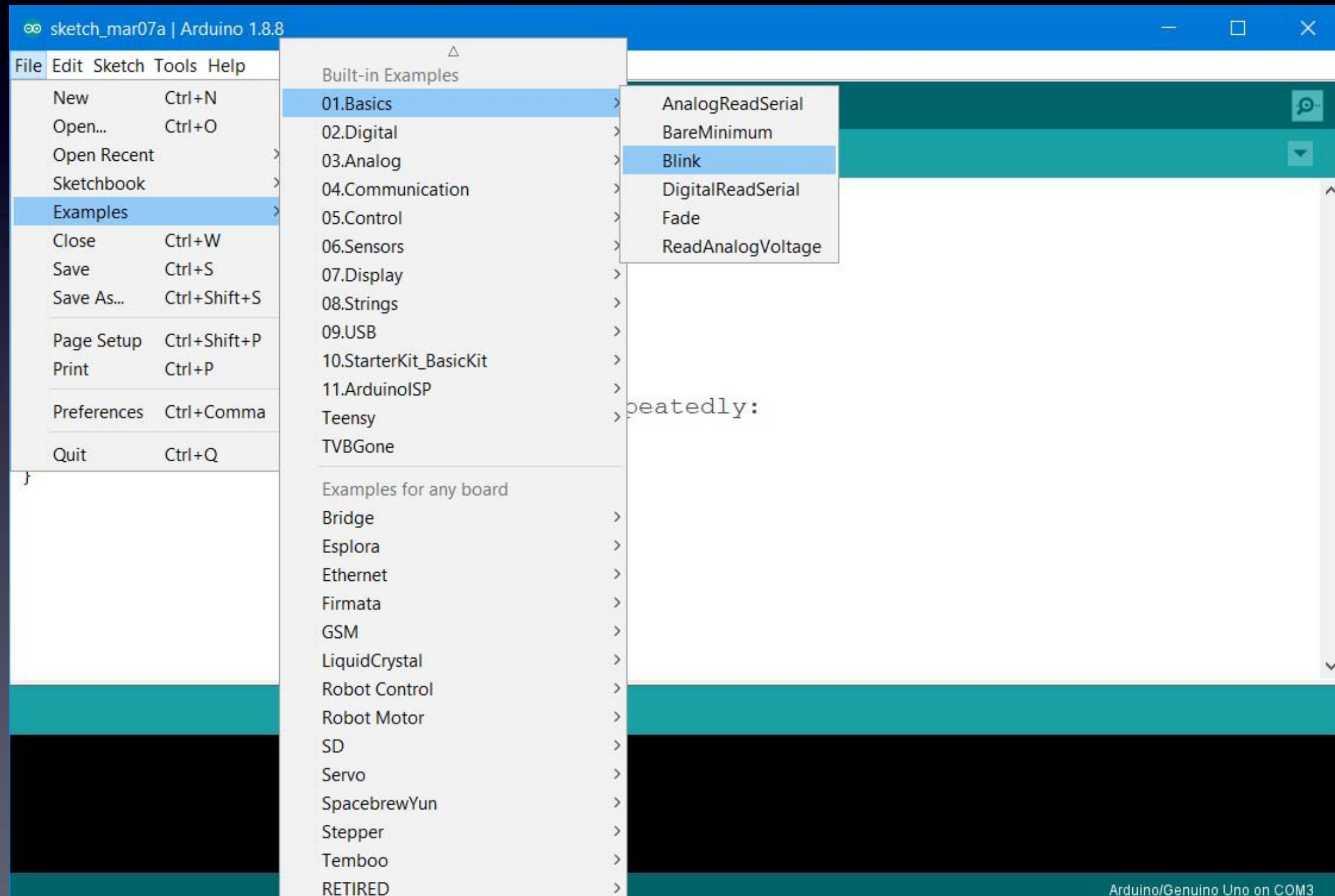

Arduino

Let's make an LED blink! Hello World

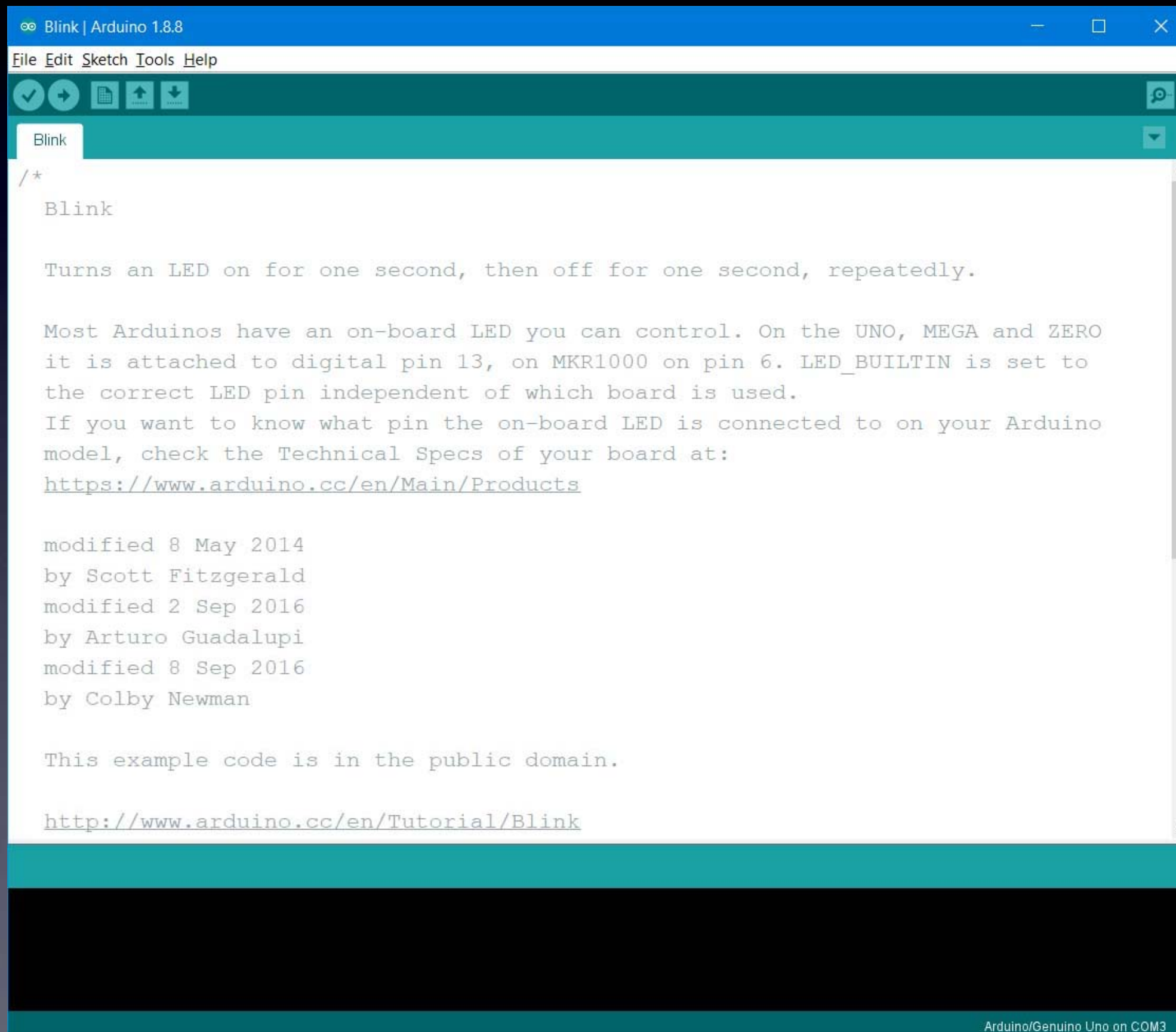

The screenshot shows the Arduino IDE interface. The title bar reads "Blink | Arduino 1.8.8". The menu bar includes "File", "Edit", "Sketch", "Tools", and "Help". The toolbar contains icons for a checkmark, a right arrow, a document, an up arrow, and a down arrow. The main editor area shows the following text:

```
/*  
Blink  
  
Turns an LED on for one second, then off for one second, repeatedly.  
  
Most Arduinos have an on-board LED you can control. On the UNO, MEGA and ZERO  
it is attached to digital pin 13, on MKR1000 on pin 6. LED_BUILTIN is set to  
the correct LED pin independent of which board is used.  
If you want to know what pin the on-board LED is connected to on your Arduino  
model, check the Technical Specs of your board at:  
https://www.arduino.cc/en/Main/Products  
  
modified 8 May 2014  
by Scott Fitzgerald  
modified 2 Sep 2016  
by Arturo Guadalupi  
modified 8 Sep 2016  
by Colby Newman  
  
This example code is in the public domain.  
  
http://www.arduino.cc/en/Tutorial/Blink*/
```

At the bottom right of the IDE, the text "Arduino/Genuino Uno on COM3" is visible.

Arduino

Let's make an LED blink! Hello World

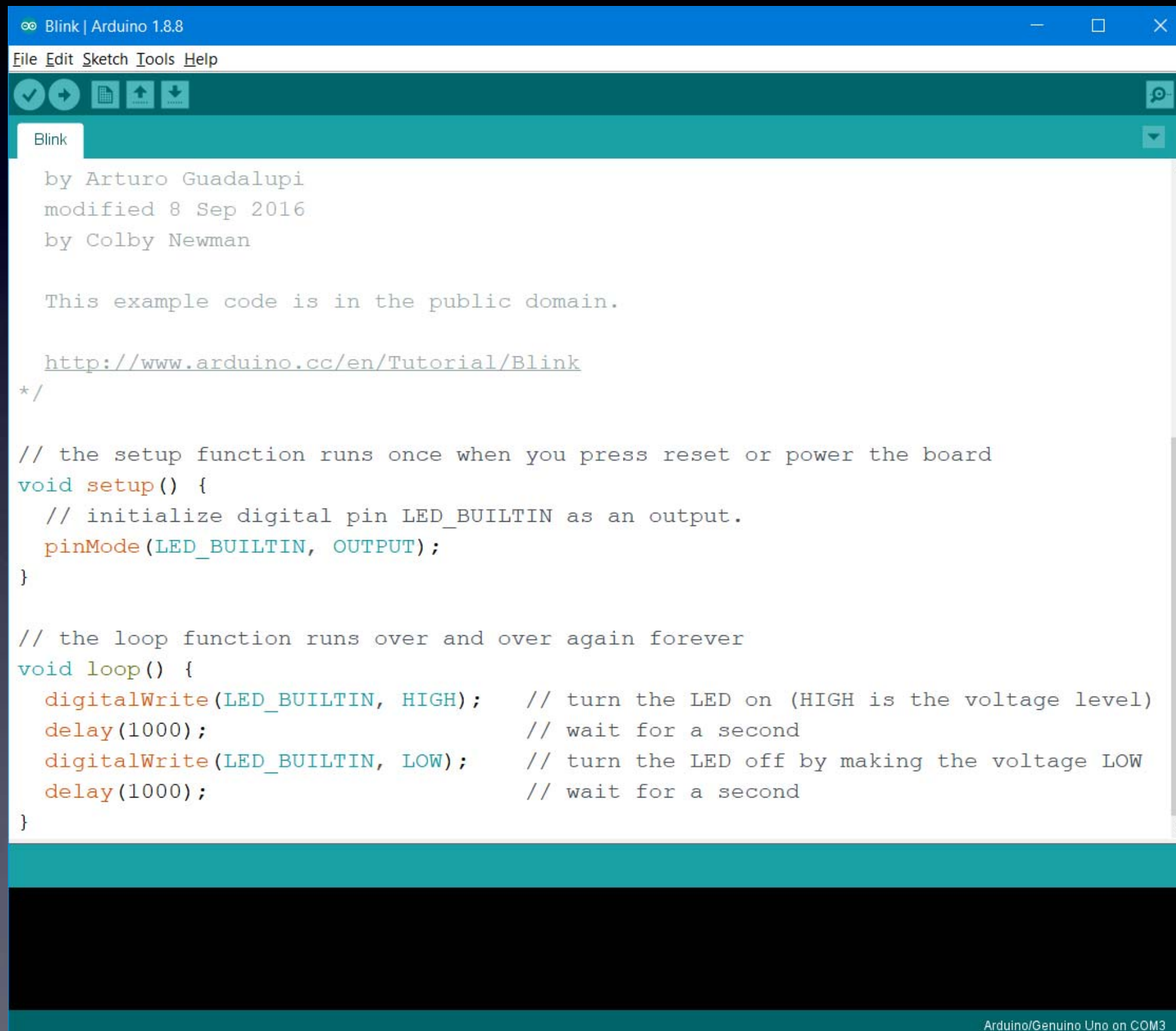
The image shows a screenshot of the Arduino IDE interface. The window title is "Blink | Arduino 1.8.8". The menu bar includes "File", "Edit", "Sketch", "Tools", and "Help". The toolbar contains icons for a checkmark, a right arrow, a document, an upload arrow, and a download arrow. The sketch name "Blink" is shown in a tab. The code editor contains the following text:

```
by Arturo Guadalupi
modified 8 Sep 2016
by Colby Newman

This example code is in the public domain.

http://www.arduino.cc/en/Tutorial/Blink
*/

// the setup function runs once when you press reset or power the board
void setup() {
  // initialize digital pin LED_BUILTIN as an output.
  pinMode(LED_BUILTIN, OUTPUT);
}

// the loop function runs over and over again forever
void loop() {
  digitalWrite(LED_BUILTIN, HIGH); // turn the LED on (HIGH is the voltage level)
  delay(1000); // wait for a second
  digitalWrite(LED_BUILTIN, LOW); // turn the LED off by making the voltage LOW
  delay(1000); // wait for a second
}
```

At the bottom right of the IDE, the text "Arduino/Genuino Uno on COM3" is visible.

How to Hack Arduino Programs (“Sketches”)

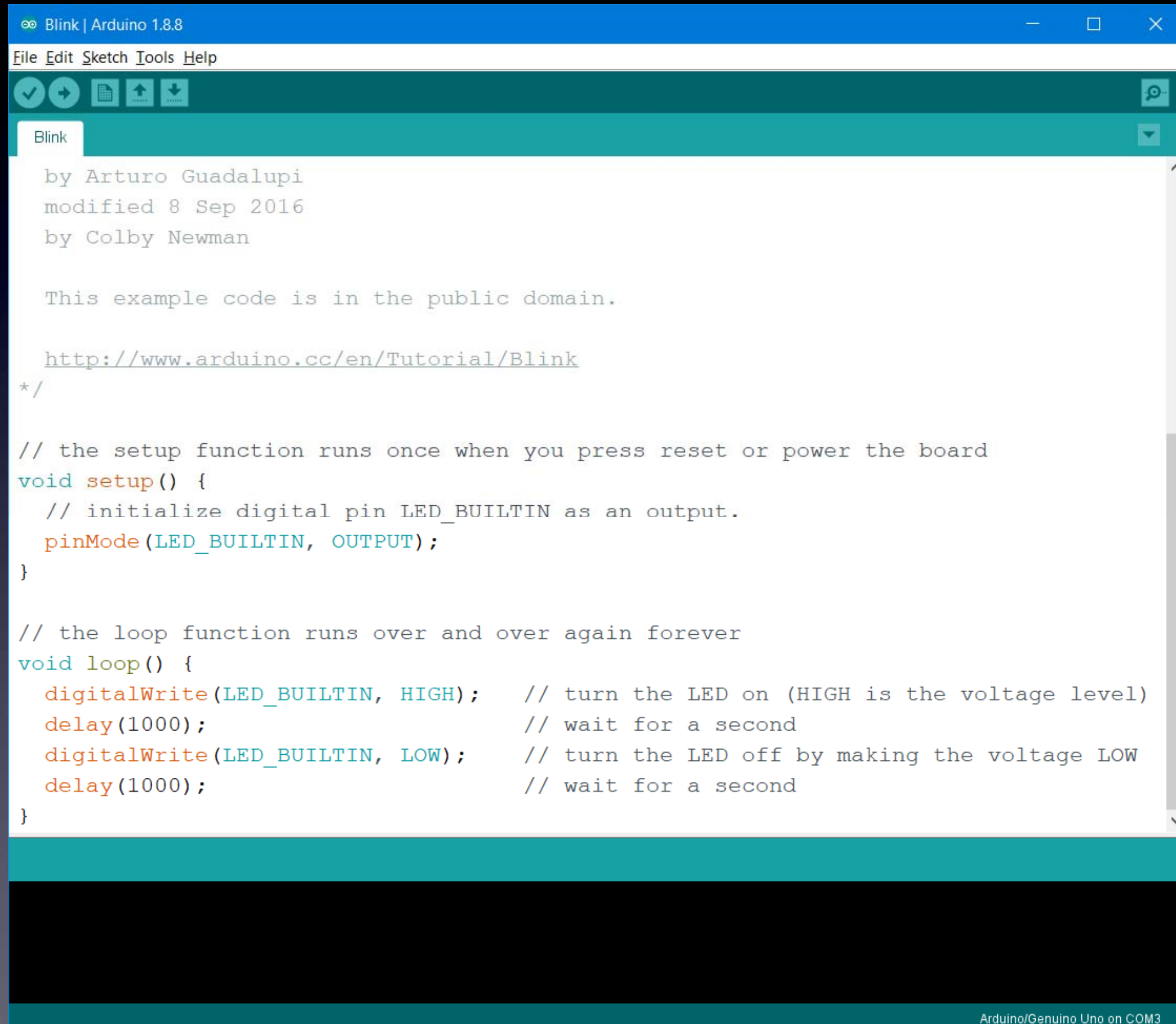

The image shows a screenshot of the Arduino IDE interface. The title bar reads "Blink | Arduino 1.8.8". The menu bar includes "File", "Edit", "Sketch", "Tools", and "Help". Below the menu bar is a toolbar with icons for saving, running, and uploading. The main workspace shows a sketch named "Blink" with the following code:

```
by Arturo Guadalupi
modified 8 Sep 2016
by Colby Newman

This example code is in the public domain.

http://www.arduino.cc/en/Tutorial/Blink
*/

// the setup function runs once when you press reset or power the board
void setup() {
  // initialize digital pin LED_BUILTIN as an output.
  pinMode(LED_BUILTIN, OUTPUT);
}

// the loop function runs over and over again forever
void loop() {
  digitalWrite(LED_BUILTIN, HIGH); // turn the LED on (HIGH is the voltage level)
  delay(1000); // wait for a second
  digitalWrite(LED_BUILTIN, LOW); // turn the LED off by making the voltage LOW
  delay(1000); // wait for a second
}
```

At the bottom right of the IDE, the text "Arduino/Genuino Uno on COM3" is visible.

How to Hack Arduino Programs (“Sketches”)

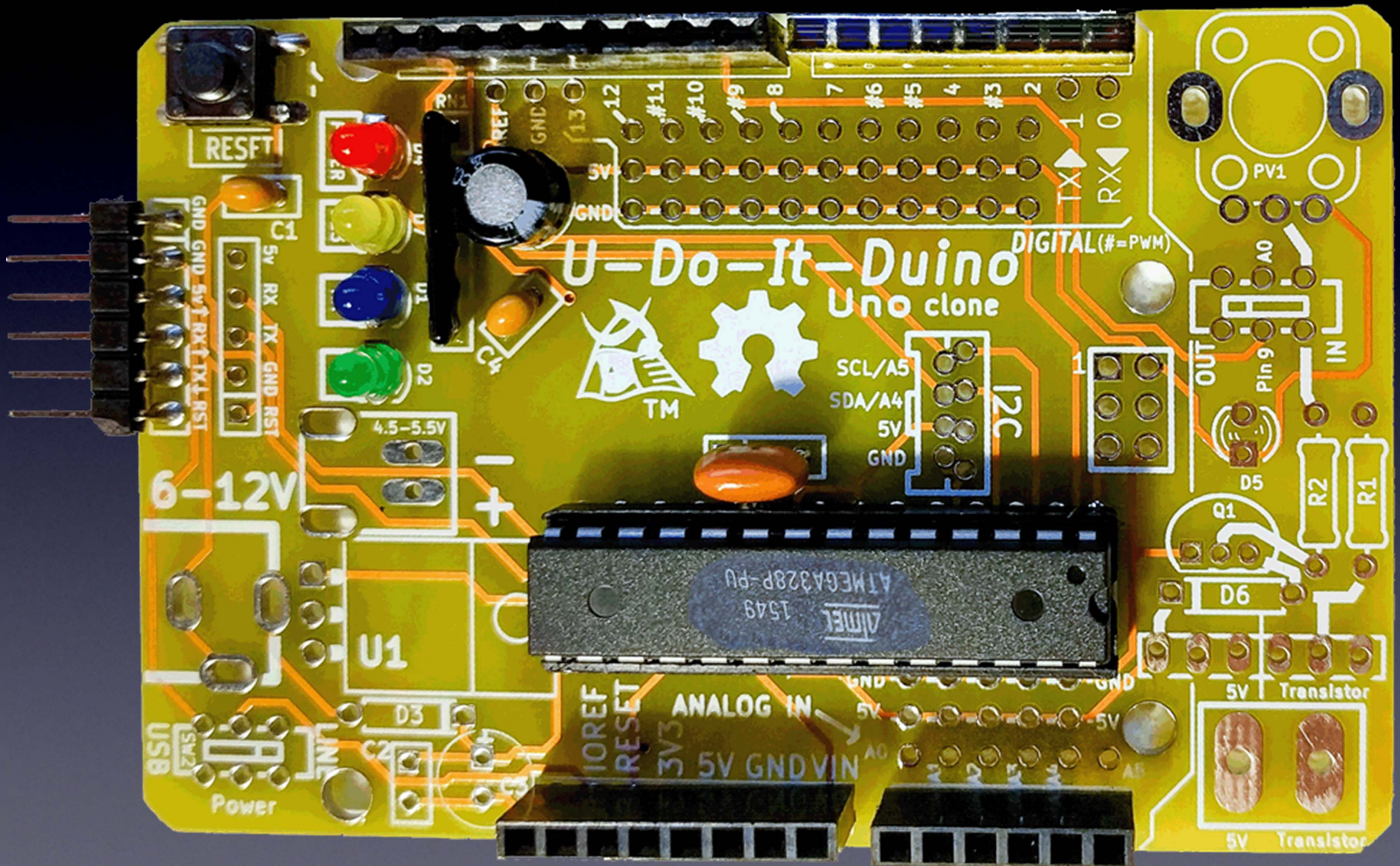

How to Use Solderless Breadboards

Solderless Breadboard

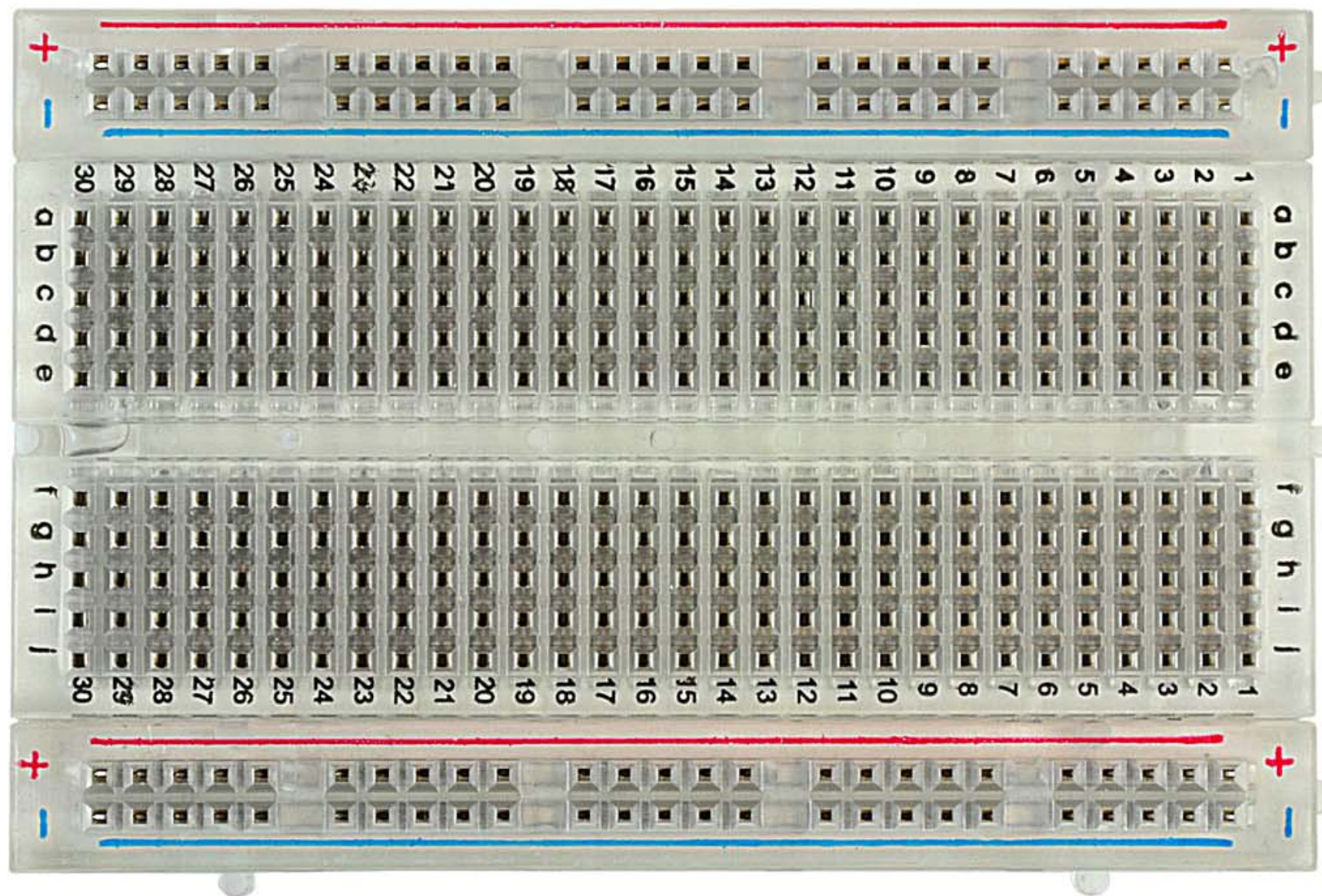

How to Use Solderless Breadboards

Solderless Breadboard with LED

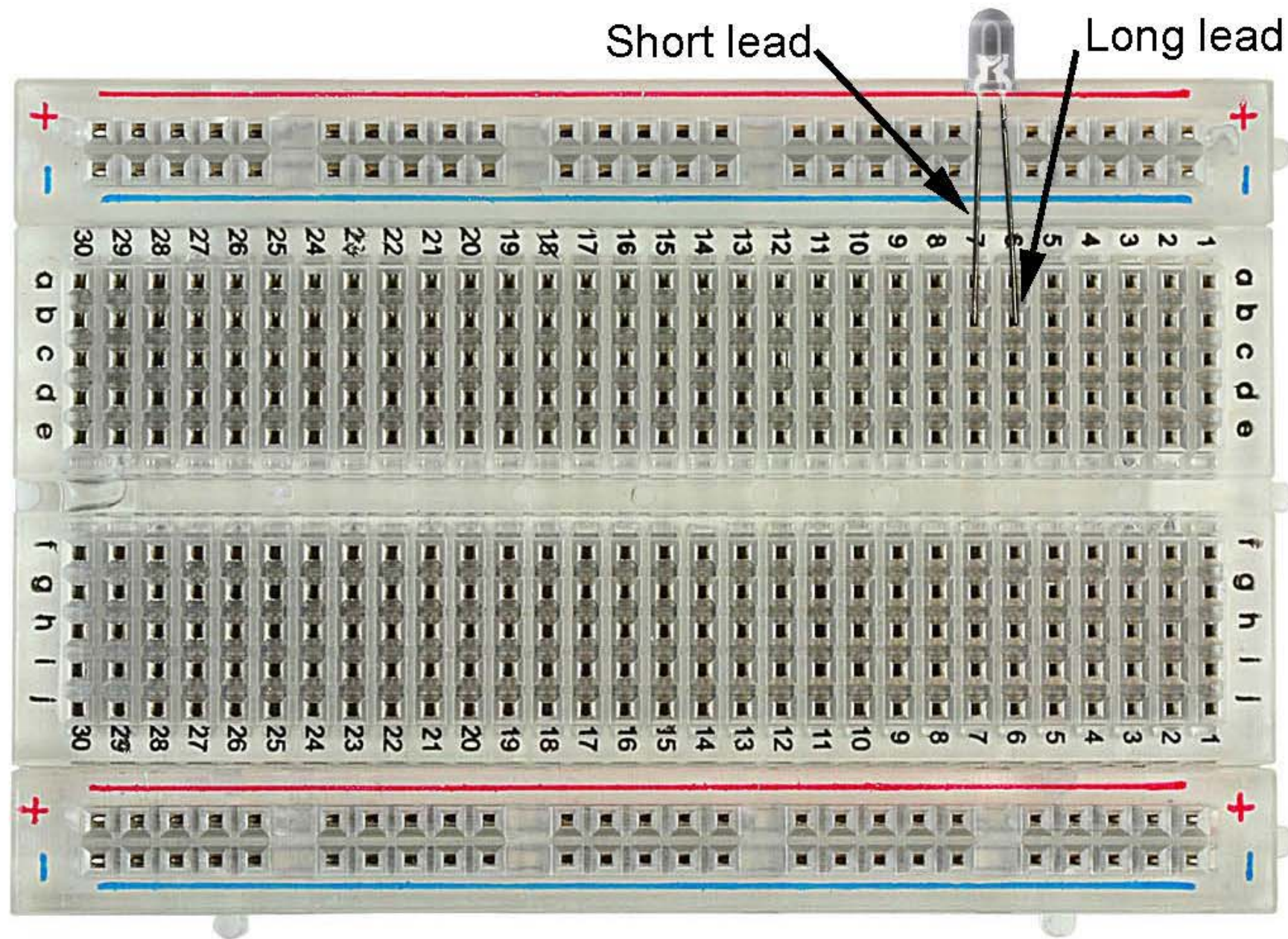

How to Use Solderless Breadboards

Solderless Breadboard with LED and wires

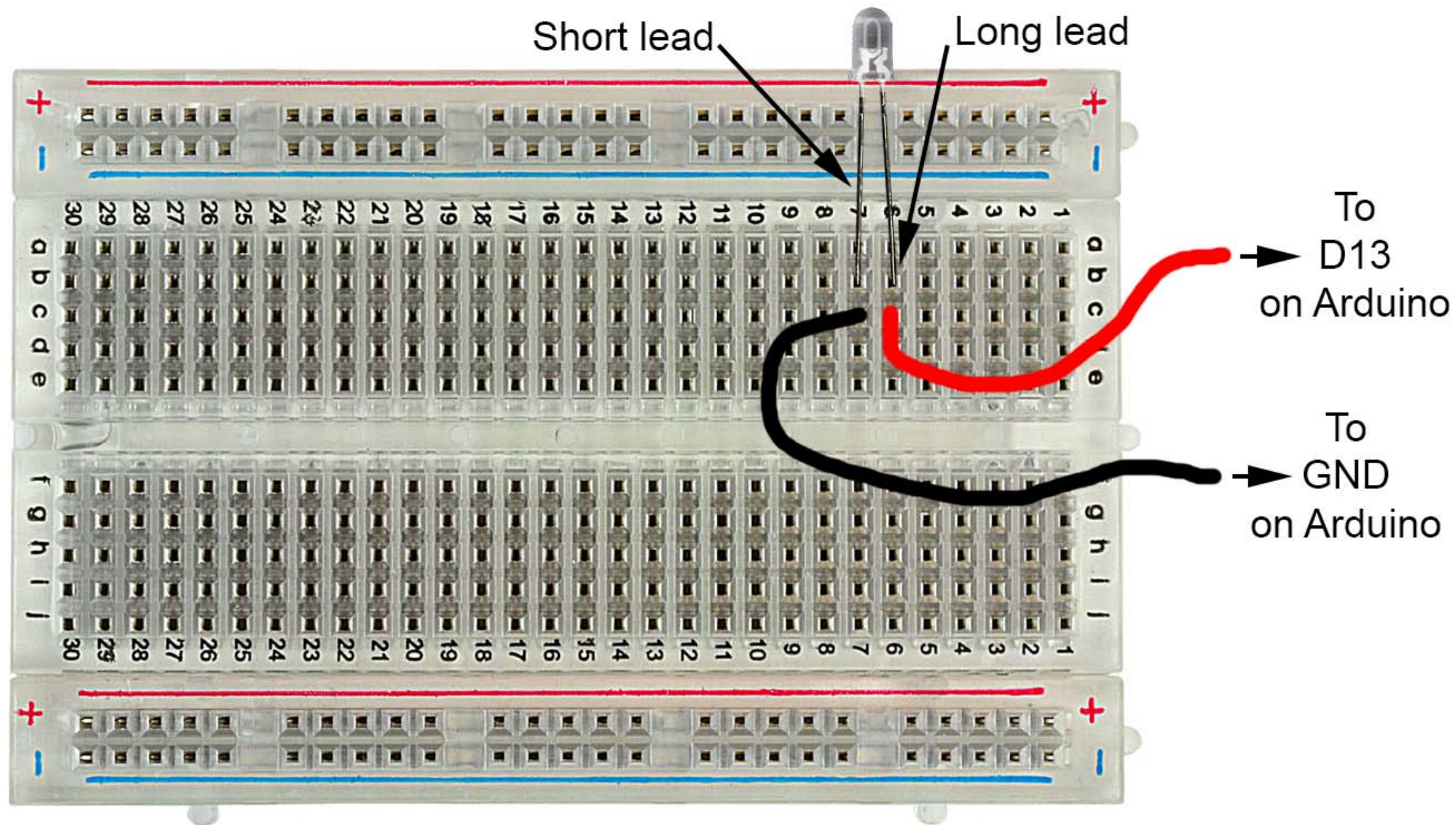

How to Use Solderless Breadboards

Solderless Breadboard with LED and Resistor and wires

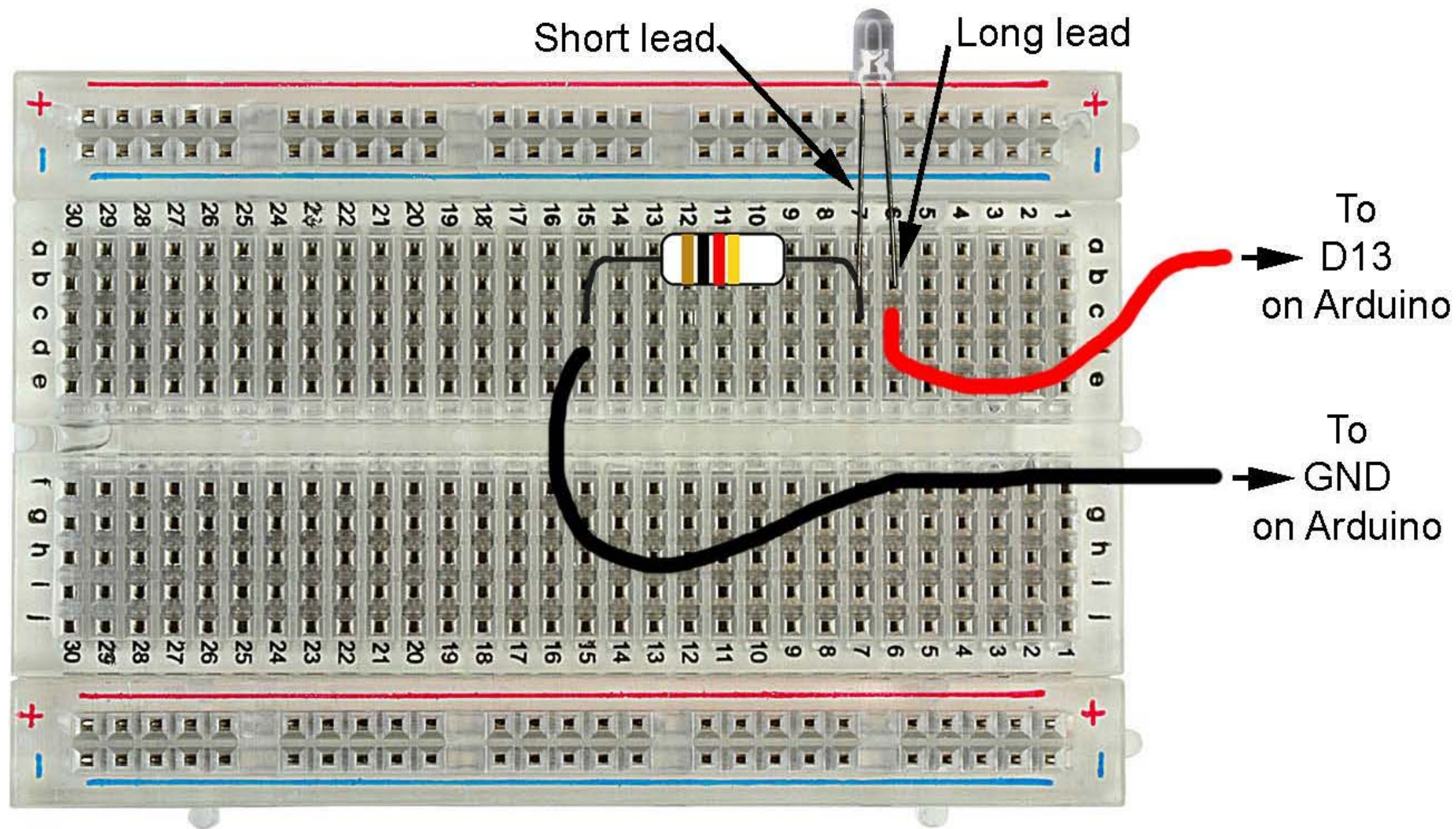

How to Read a Schematic

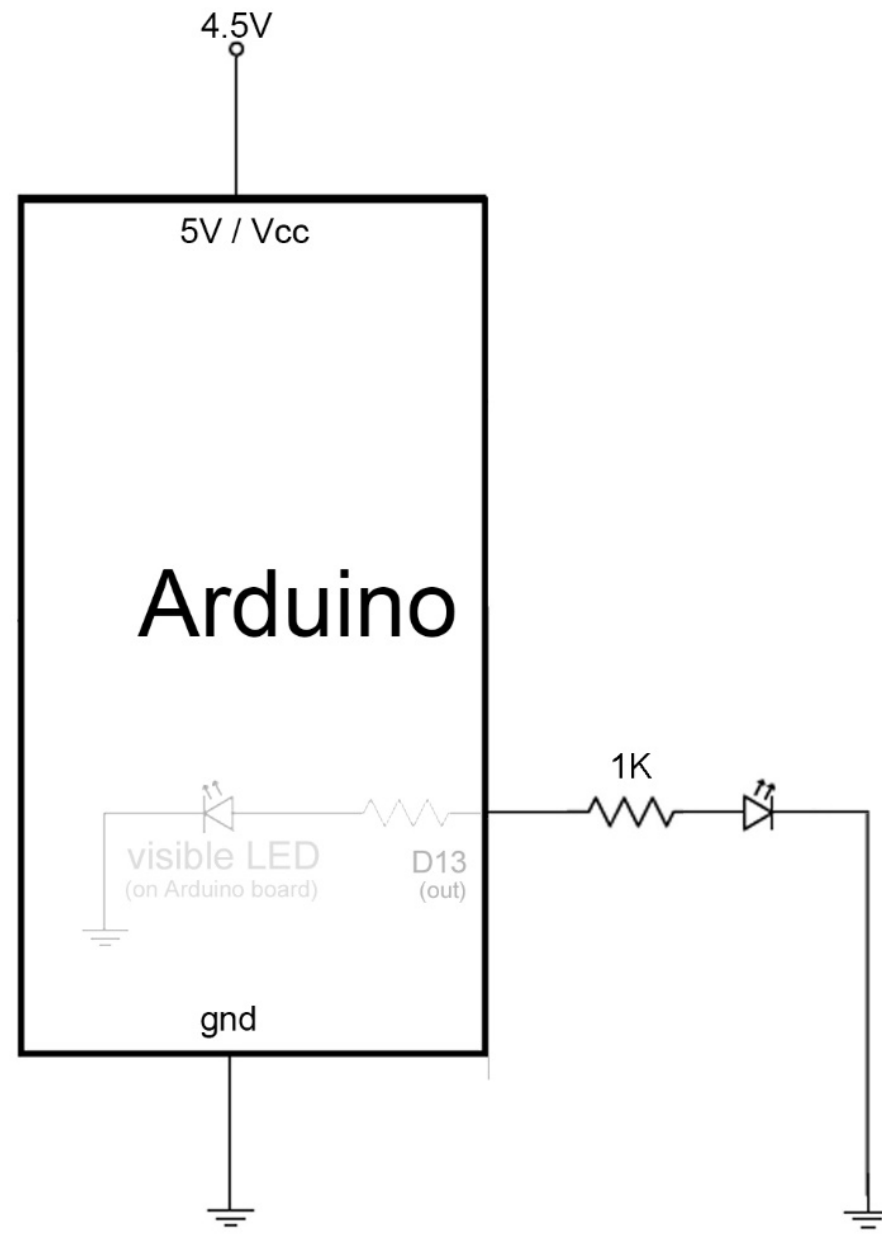

How to Read a Schematic

Arduino For Total Newbies

4-Sep-2015

Mitch Altman (original TV-B-Gone hardware and firmware, modified TV-B-Gone Arduino design)
Limore Fried (firmware modifications, kit design)
Ken Shirriff (original modifications for Arduino)
Johannes Schneemann (documentation)

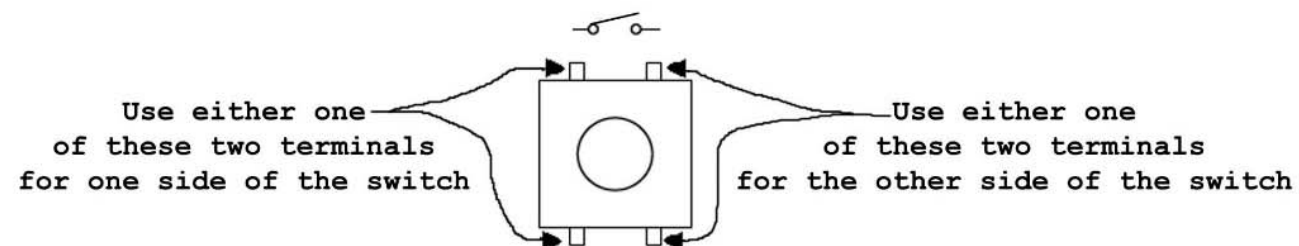
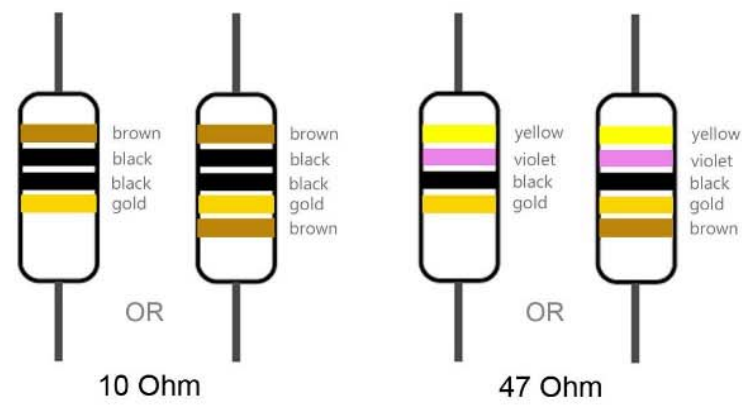
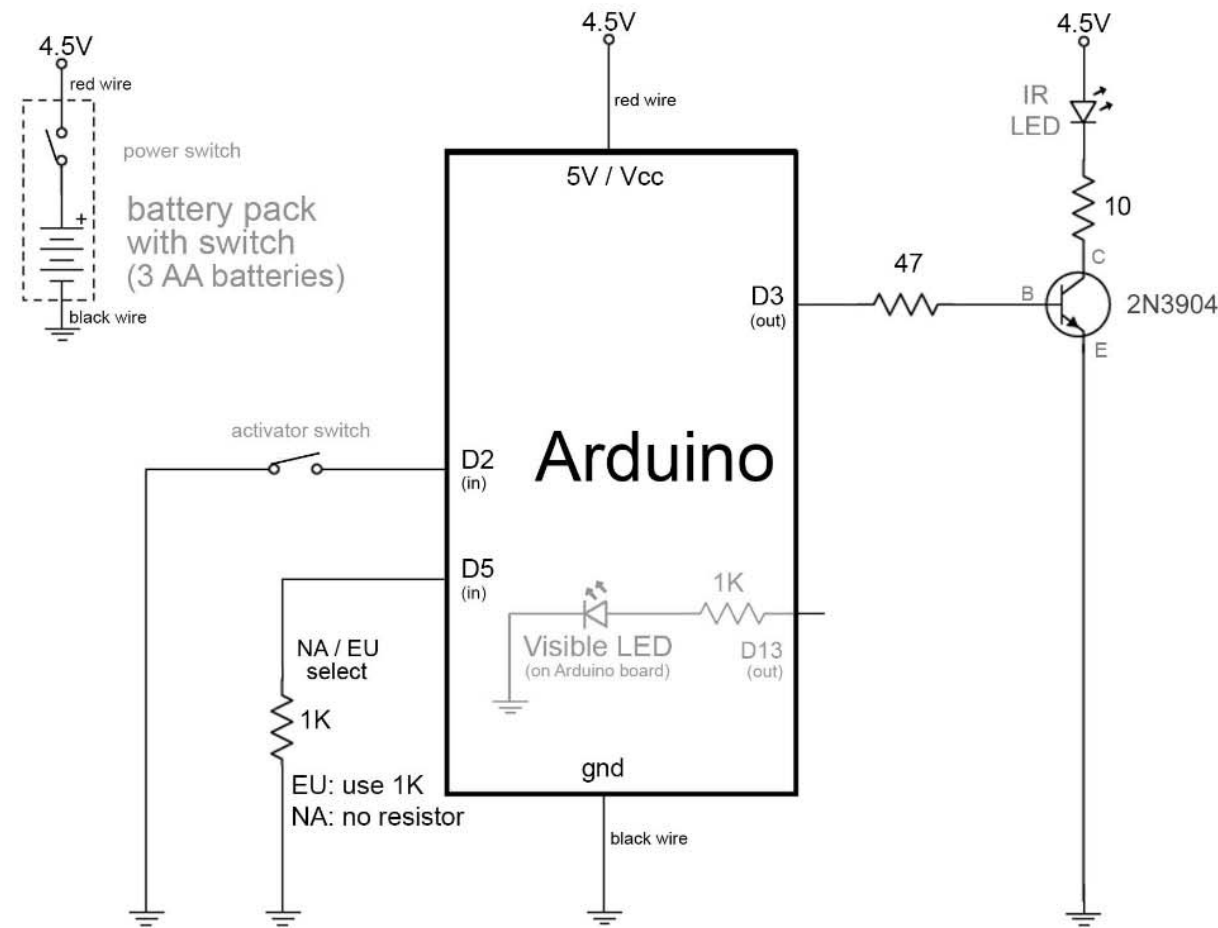

Parts Pack Contents

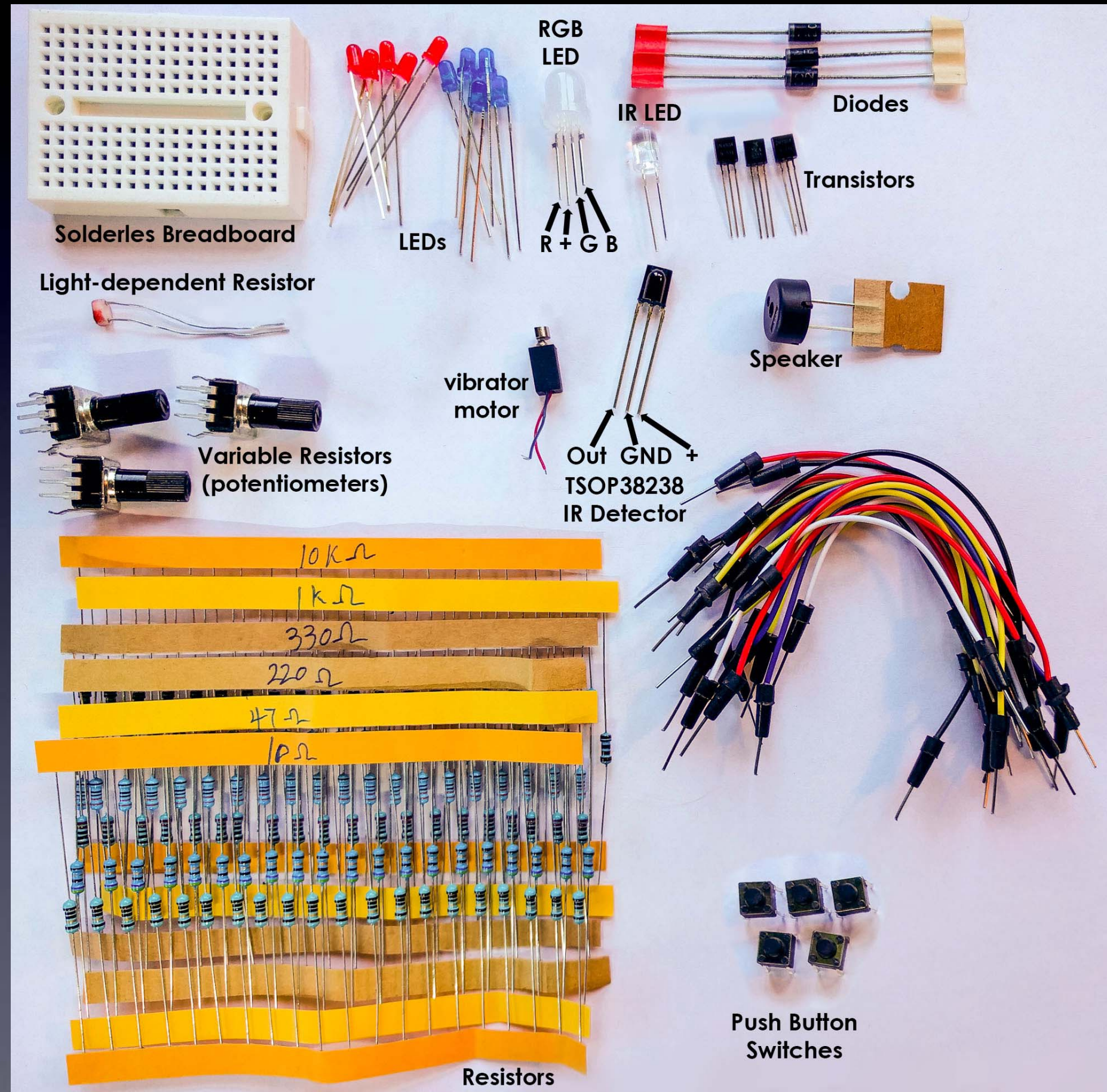

If you want to:

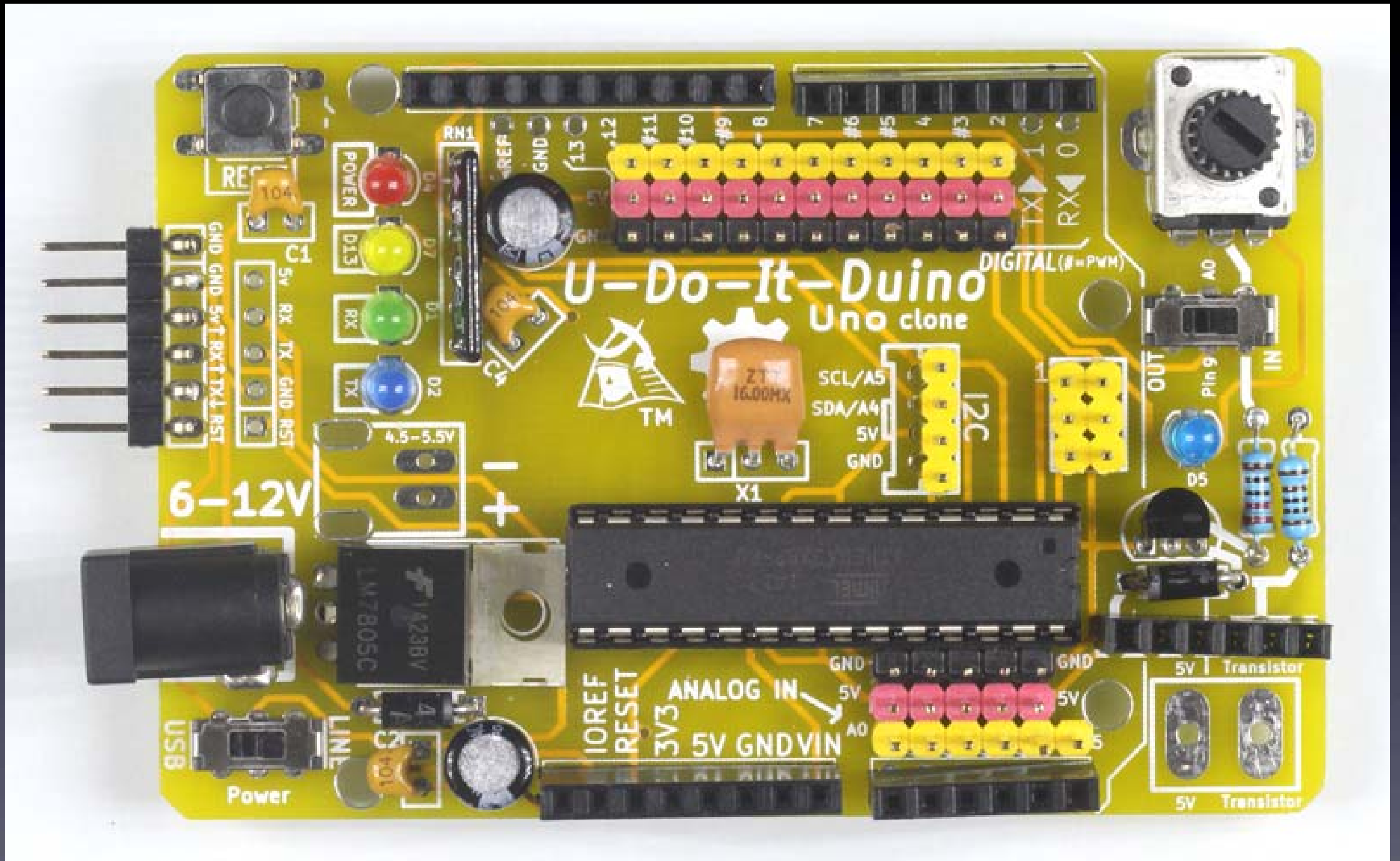

<https://cornfieldelectronics.com/cfe/u-do-it-duino-complete.php>

(or just search for: U-Do-It-Duino online)



Please Remember:

to

Wash your hands

I have these
Toolkits
for sale

Tools

